

# STANDARD GUIDELINE FOR RURAL HOUSING IN DISASTER PRONE AREAS OF BANGLADESH



হাউজিং এন্ড বিল্ডিং রিসার্চ ইন্সটিটিউট  
**Housing and Building Research Institute**  
Ministry of Housing and Public Works

# STANDARD GUIDELINE FOR RURAL HOUSING IN DISASTER PRONE AREAS OF BANGLADESH



হাউজিং এন্ড বিল্ডিং রিসার্চ ইন্সটিটিউট  
**Housing and Building Research Institute**  
Ministry of Housing and Public Works

---

**Published in**

February 2018, Dhaka, Bangladesh

**Published by**

Housing and Building Research Institute,  
Ministry of Housing and Public Works,  
Government of the People's Republic of Bangladesh

**Developed by**

Housing and Building Research Institute,  
Ministry of Housing and Public Works  
With the support from  
Department of Disaster Management,  
Ministry of Disaster Management and Relief

**In collaboration with**

Friendship  
[www.friendship.ngo](http://www.friendship.ngo)

**With technical assistance from**

Shelter Cluster Bangladesh  
IFRC Shelter Research Unit, Luxembourg  
Housing experts and actors from Bangladesh and abroad

**Supported by**

Development Cooperation and Humanitarian Action, Grand Duchy of Luxembourg,  
Friendship Luxembourg and Luxembourg Red Cross

**Photo**

Housing and Building Research Institute  
Friendship

Housing and Building Research Institute  
120/3, Darus-Salam, Mirpur  
Dhaka-1216, Bangladesh  
Tel +880-2-9035222  
Fax +880-2-9035057 [www.hbri.gov.bd](http://www.hbri.gov.bd)

---

# FOREWORD

Bangladesh is predisposed to numerous natural extremities due to its geographic location and meteorological features. Every year the country faces extreme natural phenomena that significantly affect the overall livelihood of the inhabitants. Predominantly human habitat is the most affected paradigm, facing the utmost adverse impacts of nature. Although traditional rural houses are fairly well adapted to the local culture, environment and resources, nonetheless they suffer from serious inadequacies. Owing to the very low incomes, employment and severe poverty that prevail in the areas, the rural populace has little choice but to continue to stick to the indigenous materials, non-engineered methods and designs, not only because of their low costs but also because of their familiarity and acceptability.

The Government is committed to a substantial reduction of disaster risk and losses in lives, livelihoods, health and in the economic, physical, social, cultural and environmental assets by strengthening the resilience of affected and at – risk people. Housing is one of the highest priorities in the Government agenda, therefore, Housing and Building Research Institute (HBRI) is strongly determined to promote sustainable building materials and construction techniques for both rural and urban housing with the aim of reducing the risks associated with natural calamities. With the support from Ministry of Disaster Management and Relief and the Department of Disaster Management (DDM), Housing and Building Research Institute (HBRI) provided the technical support and developed standards and sample designs in collaboration with Friendship and Shelter Research Unit of International Federation of Red Cross and Red Crescent Societies (IFRC).

Through this collaboration, an intensive research was conducted considering monsoons, cyclones, floods, low-lying, extreme weather and landslides. The team reviewed existing resources and visited many affected places to learn existing qualitative housing designs for various disaster types and material techniques prevalent in Bangladesh. This guideline focuses on housing designs that have an expected structural durability of at least 30 years. As consequences, the designs presented in this guideline rely on a combination of formal engineering expertise and approved non-engineered construction method. The guideline advocates the idea that a more optimal use of these resources is not only possible, but is the best strategy to realize a substantial improvement of the rural housing stock of Bangladesh. It will give a role to all people involved in the housing sector, solicit all types of relevant skills and knowledge, include a variety of local and newly introduced materials, present strategies for an optimal quality-cost balance, and be sensitive to issues of land security and lastly, is an important tool to promote and facilitate coordination around rural housing. This approach will work towards reducing the impact of future disasters on the rural housing stock of Bangladesh and building a greater resilience.

The guideline has been developed with the significant cooperation from Runa Khan of Friendship, Marc Elvinger of Friendship-Luxembourg, Cecilia Braed of SRU-IFRC. I would like to thank the Development Cooperation and Humanitarian Action, Grand Duchy of Luxembourg, Friendship-Luxembourg and Luxembourg Red Cross for their support in this endeavor.

The inclusive, consultative process used to develop this guideline ensured that participation from the respective government departments, UN, International, National and local organization, Shelter Cluster in Bangladesh, Universities, Media, Civil Society, Experts, Masons, affected people and community members. Special appreciation goes to Ar. Mohammad Fuad Abdul Quaium, Ar. Shafinaz Sameen, Ar. Tamanna Rahman, Ar. Mohammad Tosnimul Hassan, Ar. Tamanna Mannan, Ratan Kumar Poddar (Caritas Bangladesh), Hasibul Bari (Shelter Cluster and IFRC), Broja Gopal Saha (CDD), Muhammad Mamtaz Uddin (German Red Cross), Md. Abdul Alim (ActionAid), Md. Bodiuzzaman, Engr. K. M. Khaleduzzaman and Maria Aktar (Friendship). Kazi Amdadul Hoque of Friendship has facilitated the technical consultation process and coordination in management.

I feel confident that with the support of all housing actors, these guidelines will be successfully implemented to increase the resilience of the rural housing stock in Bangladesh. I wish all stakeholders a continued fruitful collaboration in future to realize this utmost important initiative.



**Mohammad Abu Sadeque PEng**  
Director  
Housing and Building Research Institute



## RATIONALE OF THIS GUIDELINE

Bangladesh is predisposed to numerous natural extremities due to its geographic location and meteorological features. Every year the country faces multiple exposures to extreme natural phenomena that significantly affect the overall livelihood of the inhabitants. Predominantly housing is the most affected paradigm, facing the utmost adverse impacts of nature. Although Bangladesh has shown responsive approaches to disaster risk reduction and management, lack of an inclusive policy and guideline at a national level is obstructing the successful outcome of the overall process in most of the cases. In order to address the greater need of the nation, an inevitable demand has been felt to formulate a national guideline and design manual for rural areas specially areas prone to natural extremities. The aim of formulating this catalogue is to assist both the housing facilitators and end users living in extreme natural conditions.

### KEY FACILITATOR

Friendship took the endeavor in November 2014, considering the need, willingness and opportunities to improve the co-ordination and quality of future

housing initiatives through the development of proposed national guideline. The key facilitators regarding this approach are:

- ▶ The Department of Disaster Management (DDM)
- ▶ Housing and Building Research Institute (HBRI)
- ▶ Friendship
- ▶ Shelter Research Unit (SRU) of International Federation of Red Cross and Red Crescent Societies(IFRC)

### TARGET GROUPS

Natural phenomena like cyclones or flood become disasters because of lack of awareness on how to construct disaster resilient houses by using feasible technologies. It is intended that this design catalogue will help in reducing the undue losses and hardships to the people living in areas exposed to extreme natural phenomena like cyclone, flood, river erosion

etc. and that it becomes an important tool in making Bangladesh less vulnerable to disasters. This catalogue is targeted at helping the house owners and local artisans to improve their skills and learn about the disaster-resilient building technologies. It can also be used by site supervisors, engineers, concerned NGO, donors and other facilitators while providing the necessary housing assistance.

---

# OVERVIEW

## PART ONE

The guidelines maintained coherence with other existing policies in country like Sixth Five Year Strategic Plan, Seventh Five Year Strategic Plan, National Housing Policy: embankments, water and sanitation, livelihoods creation in rural areas, climate change, land management, forestry management, engagement of (I) NGOs etc.

The Guideline considered as part of the consultation process about the Bangladesh context of growing economy and growing household income levels, so disaster response has to foster the development agenda. These guidelines also recognize the need to develop clear standards and examples of resilient technologies. Based on Disaster Management Policies, the Disaster Management Act, in particular to housing, lessons learned and policy formulation since cyclone Sidr, Rural Poverty Alleviation Policies, Bangladesh Climate Change Strategy and Action 2009, reviewed in developing the guidelines.

International documents like Universal Declaration of Human Rights, Sphere Standards for definition of what is adequate housing with required standards, Sustainable Development Goals, Sendai

Framework for Disaster Risk Reduction 2015-2030 and many others also reviewed and adjusted with view of country context and needs. These guidelines emphasis on core and technical standards for disaster preparation, response and early recovery work of the international sheltering community: Shelter Cluster etc.: both policies as practical standards and guidelines.

## PART TWO

The minimum standards of this guideline in part 2 to be adhered to by all actors, ensure that a minimum level of quality is reached in all emergency sheltering and housing projects pre and post disaster. The housing designs are meant as a source of inspiration. These National Guidelines open the choice between different housing designs, responding to specific local needs and opportunities as discussed with communities and households, and in accordance with specific working methods of external agencies.

The compliance mechanism of these Guidelines foresees that model housing designs can be taken from these Guidelines, and should be adapted by house owners or external agencies to fit each

specific situation; All final housing designs need to comply with the minimum standards.

Minimum standards for adequate housing: These set the standards for any house to classify as a safe, healthy and dignified living environment.

Minimum standards for implementing agencies: These standards stipulate how external agencies are to conduct the process of implementing a housing project and emergency sheltering to maximize the long term profit for the affected population.

Minimum technical standards for emergency sheltering: These standards set out the options for material support that can be provided immediately after disaster to protect affected populations from the open sky.

Minimum technical standards for safer housing: These standards set the technical requirements of safer housing for different hazards and different materials and techniques.

---

## PART THREE

The guideline for resilient house design focuses on housing designs that have an expected structural durability of at least 30 years.

Rural housing construction in Bangladesh is largely informal and non-engineered. The Bangladesh National Building Code doesn't cover the entire variety of conditions, materials, techniques and living practices in current rural housing in Bangladesh. Likewise, structural and material engineering expertise has not been systematically engaged in rural housing design. These Guidelines can't fill this gap, as this would require multiple years of study, testing and development.

All structural elements and the structural design of the house can be expected, based on prior experience to resist 'regular disaster intensities' for at least 30 years, provided adequate maintenance is done. The non- structural elements of the house however, such as the wall cladding and roofing, can have a lower durability than 30 years; these will need to be replaced during that period.

As consequence, the designs presented in part 3 of this guideline rely on a combination of formal engineering expertise and approved non – engineered construction method. In this context, the ambition of structural durability of 30 years is to be understood as:

Considering this whole initiative of developing a guideline for impact resilient house design as a fresh start, a paradigm shifting approach of focusing innovation in terms of building materials and construction technology has been accentuated. These very approaches has been necessitated owing to the growing concern for conserving ever depleting natural resources that assures the overall wellbeing

of the human being. Besides, few inspirational and equally timely movements have been perceived from the government level regarding the issue of sustainability. Few of such references that can be drawn here go as follows-

### 7th Five Years Plan

Housing and Building Research Institute will focus on bringing innovation including alternatives to traditional bricks with a target of achieving zero use of agricultural top soil for brick production, and standardization of new construction materials through research. Special emphasis will be given for extension services to disseminate newly developed technologies and building materials which will be agriculture and environment friendly, disaster resilient and affordable. It will also continue updating the Bangladesh National Building Code (BNBC) and on a pilot basis steps will be taken for construction 75 low cost multi-storied residential building at different villages during the 7th five year Plan period.

### Prime Minister's directives for HBRI

An intense initiative has to be undertaken to publicize the HBRI's act of innovations regarding new building materials. Appropriate planning has to be drafted to properly utilize and apply the research outcomes. Ferro cement must be introduced in various housing and rural settlement development projects. Research initiatives must be undertaken regarding construction of hollow blocks from river-dredged sand. Measures must be taken to produce environment-friendly bricks from river- dragged soil.

### Bangladesh and COP-21

In this INDC (Intended Nationally Determined Contributions ) Bangladesh pledged an unconditional

5% greenhouse gas emission cut by 2030, adding that with financing and technology support it will cut emissions by 15%.

### Bangladesh and COP-22

Bangladesh address the climate challenges and calling for global efforts to address the issue of climate-induced migrants to make the objectives of SDGs successful.

### Bangladesh and COP-23

Strongly raised the climate change issues emphasized the importance of the Paris agreement and gave the opinion that the integration of NDCs and SDGs into national development process is important.

### Sustainable Development Goals

On September 25th 2015, countries adopted a set of goals to end poverty, protect the planet, and ensure prosperity for all as part of a new sustainable development agenda. Each goal has specific targets to be achieved over the next 15 years. Among 17 goals are set, this guideline will turn out to be an exemplary model portraying minimum 08 of them; like:

#### Goal 01

No Poverty: End poverty in all its forms everywhere

#### Goal 02

Zero Hunger: End hunger, achieve food security and improved nutrition and promote sustainable agriculture

**Goal 03**

Good health and Wellbeing: Ensure healthy lives and promote well-being for all at all ages

**Goal 04**

Quality Education: Ensure inclusive and equitable quality education and promote lifelong learning opportunities for all

**Goal 05**

Gender Equality: Achieve gender equality and empower all women and girls

**Goal 06**

Clean Water and Sanitation: Ensure availability and sustainable management of water and sanitation for all

**Goal 07**

Affordable and Clean Energy: Ensure access to affordable, reliable, sustainable and modern energy for all

**Goal 08**

Decent work and Economic growth: Promote sustained, inclusive and sustainable economic growth, full and productive employment and decent work for all

**Goal 09**

Industry, Innovation and Structure: Build resilient infrastructure, promote inclusive and sustainable industrialization and foster innovation

**Goal 10**

Reduced Inequality: Reduce inequality within and among countries

**Goal 11**

Sustainable cities and Communities: Make cities and human settlements inclusive, safe, resilient and sustainable

**Goal 12**

Responsible consumption and Production: Ensure sustainable consumption and production patterns

**Goal 13**

Climate action: Take urgent action to combat climate change and its impacts

**Goal 14**

Life Below Water: Conserve and sustainably use the oceans, seas and marine resources for sustainable development

**Goal 15**

Life on land: Protect, restore and promote sustainable use of terrestrial ecosystems, sustainably manage forests, combat desertification, and halt and reverse land degradation and halt biodiversity loss

**Goal 16**

Peace, Justice and strong Institutions: Promote peaceful and inclusive societies for sustainable development, provide access to justice for all and build effective, accountable and inclusive institutions at all levels

**Goal 17**

Partnerships for the goals: Strengthen the means of implementation and revitalize the Global Partnership for Sustainable Development

Therefore, this changed perceptions of sustainability in relevance of the new world context enables this guideline to put an attempt in bridging the gap between the dynamic innovative outcomes and the lessons from the traditional housing culture, where formal engineering expertise being expected to systematically introduce itself in rural housing sphere.

# CONTENTS

## PART 1 | BACKGROUND OF THE GUIDELINE

Chapter 1.	Vision, objectives and target audience .....	1
1.1	Vision underlying the guidelines .....	1
1.2	Objectives of the guidelines .....	2
1.3	Target audience of the guidelines .....	2
Chapter 2.	Context of the development of the guidelines.....	3
Chapter 3.	Capacities and vulnerabilities of housing in rural areas .....	5
3.1	Current status of housing in rural areas.....	5
3.2	Natural disasters in numbers .....	6
3.3	Impact of climate change on housing .....	9
3.4	Natural disasters in numbers .....	9
Chapter 4.	Policy framework of the guidelines.....	10
4.1	The disaster management act .....	10
4.2	Bangladesh climate change strategy and action plan,2009.....	11
4.3	The bangladesh national building code .....	11
4.4	Rural development policies .....	11
Chapter 5.	Other important documents.....	12
5.1	Universal declaration of human rights.....	12
5.2	Sendai framework for disaster risk reduction 2015-2030.....	12
5.3	Sphere handbook.....	13
5.4	Policy paper 10 - national housing policy.....	13

Chapter 6.	Building housing capacity .....	14
6.1	Coordination and use of existitng resources.....	14
Chapter 7.	How to use these guidelines.....	15
7.1	Adequate housing end emergency sheltering.....	15
7.2	Prescriptive and flexible guidelines, compliance mechanism ...	15
7.3	Awareness raising and capacity building needs.....	16
7.4	Overview of standards.....	16
7.5	Monitoring and quality assurance.....	16
7.6	Limitations of the guidelines.....	17

## PART 2 | MINIMUM STANDARDS

Chapter 1.	Minimum standards for adequate housing.....	19
Chapter 2.	Minimum standards for implementing agencies.....	21
2.1	Types of housing projects implemented by external agencies..	21
2.2	Underlying principles.....	22
2.3	Minimum standards for implementing agencies.....	22
Chapter 3.	Minimum technical standards for emergency sheltering.....	24
3.1	Material support options in emergencies.....	24
3.2	Composition of the nfi kit.....	25
3.3	Composition of the shelter kits .....	26
3.4	Awareness raising and technical support.....	28
3.5	Design of an emergency shelter.....	29
3.6	Appendix: A basic guideline on shelter upgrading.....	34

Chapter 4.	Minimum technical standards for safer housing.....	36
4.1	Definition of safer housing .....	36
4.2	Estimating threats impacting on a house on macro, mezzo and micro level.....	36
4.3	General design principles for different area .....	39
4.4	Minimum technical standards for high wind, flood and earthquake prone areas.....	41
4.5	Design examples for safer housing.....	46

### **PART 3 | DURABLE HOUSE DESIGN**

Chapter 1.	Design aspects.....	52
1.1	Basis for focus area of design.....	52
1.2	Basis for focus entity of design.....	52
Chapter 2.	Design for coastal areas .....	53
2.1	Geographic profile.....	53
2.2	Climatic features and risk factors.....	53
2.3	Hazard profile.....	53
2.4	Prevailing practices.....	54
2.5	Design considerations.....	55
2.6	Building typology.....	55
2.7	Design rationale .....	111
Chapter 3.	Design for flood plain and char areas.....	112
3.1	Geographic profile.....	112
3.2	Climatic features and risk factors.....	112
3.3	Hazard profile.....	112
3.4	Prevailing practices.....	113
3.5	Design considerations.....	114
3.6	Building typology.....	114
3.7	Design rationale.....	141
Chapter 4.	Design for haor area .....	142
4.1	Geographic profile.....	142
4.2	Climate for design consideration.....	142
4.3	Hazard profile.....	142
4.4	Prevailing practices.....	143

4.5	Building typology.....	144
4.6	Embankment (hati) protection.....	153
4.7	Design rationale.....	159
Chapter 5.	Design for hilly areas.....	160
5.1	Geographic profile .....	160
5.2	Climatic features and risk factors.....	160
5.3	Hazard profile .....	160
5.4	Prevailing practices.....	161
5.5	Design idea.....	162
5.6	Plan.....	163
5.7	Joinery detail.....	166
5.8	Design rationale.....	168
Chapter 6.	Other forms of housing pattern .....	169
6.1	Multy story structure .....	169
6.2	Stilt house.....	187
6.3	Floating house .....	200
6.4	Load bearing earth bag house.....	203
Chapter 7.	Design measures for services.....	206
7.1	Flexibility in accommodating access at multiple points .....	206
7.2	Service accommodation and future expansion.....	207
7.3	Sanitation models.....	208
7.4	Universal accessibility .....	211
Chapter 8.	End user improvisations and Non-engineered measures .....	213
Note.....		216
Reference.....		217
Bibliography .....		218
Housing actors from different organization participated .....		219





PART ONE

# BACKGROUND OF THE GUIDELINE



People stuck inside house due to water infiltration

## CHAPTER ONE

# VISION, OBJECTIVES AND TARGET AUDIENCE

### 1.1 VISION UNDERLYING THE GUIDELINES

The majority of the population of Bangladesh lives in rural area and their standard of living in terms of protection and safety is very low. Under difficult natural conditions, the country is extremely prone to natural disasters such as floods, cyclones and earthquakes which pose a great threat to life and property, especially in the rural areas where poverty is widespread. Apart from the physical damage that such disasters cause to the people's property, they also have a great negative impact on the country's economic situation.

After any disasters huge investments are made by the affected people themselves as well as by government and numerous NGOs supporting research and training institutions, these guidelines are an invitation to increase efforts in research and knowledge creation in rural housing pre and post disaster. Using these guidelines as a solid starting point, they open up multiple opportunities for research and innovation as well as expanding and developing the evidence base.

The National Guidelines provide the government on all levels with a tool to efficiently and transparently validate and coordinate rural housing projects based on clear standards for safe, healthy and dignified housing. To promote context specific solutions, the types of housing projects listed in the guidelines give model examples of a whole variety of possibilities that contribute to improve the rural housing stock in the different regions of recovery efforts. In order to guide these various post-disaster reconstruction-initiatives towards a more sustainable approach the formulation of National Guidelines is critical to fill the gap of lacking regulations for emergency and recovery sheltering and overcome the fragmentation within the rural housing sector in Bangladesh. To be most efficient and effective, investments made in sheltering and reconstruction should serve to improve the quality, safety and durability of the rural housing stock rather than focusing on speedy of delivery of maybe poor solutions.



## 1.2 OBJECTIVES OF THE GUIDELINES

### Overall Objective

Improve the rural housing of Bangladesh, pre and post disaster, to substantially improve the living conditions of the rural population, to increase resilience to future disasters and to introduce environmentally sustainable model of rural house building.

### Specific Objectives

- ▶ Acquire a better understanding of and raise awareness on what adequate and more resilient rural housing is for Bangladesh;
- ▶ Promote and facilitate optimal use of the resources available for rural housing: people, skills, knowledge, materials, funds and land;
- ▶ Motivate improvement of the existing rural housing;

- ▶ Guide post disaster sheltering interventions, towards greater resilience of rural housing;
- ▶ Promote innovative building material and construction technologies that can help achieve social and environmental sustainability.

## 1.3 TARGET AUDIENCE OF THE GUIDELINES

The national guidelines target all organisations involved in emergency sheltering, reconstruction and rural housing in Bangladesh. Each of these organisations has a different role to play in the improvement and development of the rural housing stock in the country and can use these guidelines accordingly.

For shelter and housing actors that undertake housing projects in rural Bangladesh, these Guidelines set the minimum standards that should be adhered to, in line with what is feasible in the context. Moreover, the house designs examples included in these

guidelines show how the standards of the guidelines can be realistically implemented and provide a source of inspiration to help housing actors save time on the design phase. The varieties of examples are meant to promote adequate, context-specific technologies, materials and approaches.



Household dismantled and relocated by boat

## CHAPTER TWO

# CONTEXT OF THE DEVELOPMENT OF THE GUIDELINES

These Guidelines are based on accumulated experience and aim at raising awareness on the importance of housing improvement for the resilience-enhancement of rural communities. Existing knowledge and expertise in sheltering and rural housing has been consolidated in a systematic manner through a consultative process with the objective to sustainably improve the rural housing stock in Bangladesh, pre and post disaster.

### **SEPTEMBER 2004: NATIONAL WORKSHOP ON OPTIONS FOR FLOOD RISKS AND DAMAGE REDUCTION IN BANGLADESH**

Already in 2004 after one of the most devastating floods Bangladesh had ever witnessed, a national workshop was conducted to develop a context based set of policy recommendations for flood management. This was extremely important because the floods had wreaked extreme havoc inundating 38% of the country's area. The damage was estimated to reach up to USD 2 billion and affected millions of people, the majority of them being the poor and most vulnerable. Among the various topics discussed in the workshop, one of them included the impacts of

flooding on housing, which was considered to be a fundamental matter of discussion in order to assure safety and economic stability for large parts of the population (Disaster Management Bureau: Disaster Management and Relief Division, April 2010).

### **NOVEMBER 2014: NATIONAL TECHNICAL SHELTER WORKSHOP, GAIBANDHA**

A large representation of organisations active in sheltering and housing in Bangladesh participated in the workshop, including Government, local, national and international non-profit organizations, Red Cross Red Crescent Movement members and UN agencies.

The main focus of this workshop was on technical issues of construction techniques and materials. Furthermore, a broad spectrum of subjects was discussed, such as capacity building needs on technical implementation level as well as on the level of local administrations, and the overall challenges involved in "building back better". The workshop concluded that there is need, willingness and

opportunity to improve the quality and coordination of sheltering and housing initiatives through the development of Slandered Guidelines. A final report of the workshop and an action plan for the development of Guidelines was launched by the Department of Disaster Management of the Ministry of Disaster Management and Relief in conjunction with Friendship on March 31st 2015, the Bangladesh National Disaster Preparedness Day.

### **JULY 2015 NATIONAL STANDARD GUIDELINE AND DESIGN FOR RURAL HOUSING IN DISASTER PRONE AREAS WORKSHOP, DHAKA**

Participants of the workshop (including Government, local, national and international non-profit organizations, Red Cross Red Crescent Movement members, UN agencies and research institutions) discussed and developed together the concept and drafted the table of contents for the Standard Guidelines. It was agreed that housing designs would form an integral part of the guidelines and preliminary directives and recommendations were developed for the different chapters of the guidelines.

### **OCTOBER 2015 to APRIL 2016 CONSULTATION AND REVIEW PROCESS WITH THE RELEVANT STAKEHOLDERS AND EXPERTS**

The results of the Gaibandha and Dhaka workshops formed the basis for the first draft of the Guideline. This first draft was developed in October 2015 through a consultation with different NGOs and government bodies. A field visit was then undertaken to double check and confirm its thoroughness. It was finally submitted to an external panel of housing

experts for further review. All this was achieved with the help and overseeing of the House and Building Research Institute (HBRI) of the Ministry of Housing and Public Works. The steps of such national and sub-national level review can be observed in the following timeline:

#### **8 OCTOBER 2015**

Progress sharing meeting among HBRI, NGO and Department of Disaster Management about the draft guideline, where it was decided that an extended visit and consultation program would be organized for the coastal, flood plain and haor areas. This with the purpose of gathering opinions and observe discrepancies from the original draft, through observation and consultation with local entities. HBRI's technical team with the support of Friendship oversaw the entire visit.

#### **18-19 OCTOBER 2015**

Visit costal area with draft design and Regional consultation workshop at Kalapara, Patuakhali

#### **13-14 NOVEMBER 2015**

Visit flood plain area with draft design and Regional consultation workshop at Gaibandha

#### **10-11 DECEMBER 2015**

Visit Kishorganj, Haor area with draft design  
19 December 2015: Regional consultation workshop, Sunamganj (Haor area)

#### **5-7 JANUARY 2016**

Government-NGO Coordination meeting. In the meeting the findings of the field visit (Coastal, flood plain and haor areas) are presented to the participants and the decision to incorporate the hilly area design in the guidelines is adopted.

#### **2-6 FEBRUARY 2016**

Visit hilly area with draft design

#### **13 FEBRUARY 2016**

Expert Review Workshop on draft design. The findings of all visits and consultations and feedbacks were incorporated in the Guideline and one week before the workshop the new draft was sent to the experts to review. In the workshop the experts presented their opinion and their feedback and further input was collected and integrated into the guidelines.



Households under water in low lying areas

## CHAPTER THREE

# CAPACITIES AND VULNERABILITIES OF HOUSING IN RURAL AREAS

### 3.1 CURRENT STATUS OF HOUSING IN RURAL AREAS

By far most of the rural housing stock in Bangladesh is constructed by the house owners/occupiers themselves, according to local traditions and knowledge, locally available materials and the support of local labor with their respective technical skills.

However, a substantial part of the current rural housing is below standards and fails in providing a safe, healthy and dignified living environment to its inhabitants. The underlying causes are widespread rural poverty and lack of safe land and other resources.

Aspect of rural housing	Current status
Skills and knowledge	Housing construction and future repairs is majorly done by the owner themselves. Traditional materials such as bamboo, various types of leaves and reeds, wooden, mud, burnt bricks and a few others form the basis of housing construction. Specific tasks in the construction process are attributed among men and women. Rarely, when the owner can afford it, skilled labour is hired for specialized tasks such as chemical curing of bamboo and bricks, production of concrete, etc. unskilled labourers learn such skills by working under the guidance of skilled labourers and learning by performing practically.
Materials utilised	The most common materials used in the rural areas for housing construction are traditional materials such as bamboo, timber, wood, various types of leaves and reeds, mud, tin sheets and types of netting. Rope is often used for joints and connections while plastic is used for technical detailing. Finishing and treatment of materials is commonly done by crude oil or tar. With a substantial increase in incomes of the rural population, the current housing stock is now a combination of the 'pucca' (term used throughout Southeast-Asia to define strong, high-quality buildings made of durable materials), 'semi-pucca' and 'kutcha' (term used throughout Southeast-Asia to define more makeshift structures from not-durable materials) structures. The availability of materials differs between regions and is defined by factors such as what is grown and produced locally, local purchase power, prevailing building practices, ease of transport, season etc.

Aspect of rural housing	Current status
Housing design	The housing design is influenced by various factors such as landscape and climate, availability of materials, purchasing power, local building and living practices and cultural preferences. Some housing designs may even be specific to a group of people in the country. Majority of the housing designs in rural areas is the result of decades of trial and error methods rather than engineered research.
Settlement plans	The traditional settlement patterns contain abundance of inherent knowledge in terms of disaster resilience, production of construction materials on the plot, providing space for livelihood activities etc. However, the increasing pressure on land caused by climate change has caused more people to occupy lands exposed to disaster without the benefits offered by traditional settlement.
Impact on the local construction industry	Over the last decades, new techniques, knowledge, materials etc. were introduced and adopted in rural areas. Some examples are a wider spread use of concrete and Corrugated iron sheeting. Vocational training by local NGOs, government housing loan schemes, and post-disaster housing built by organizations with the support of construction companies also introduce new technologies and approaches. The impact of these developments on the local construction industry in terms of quality and durability varies a lot.

The various local stakeholders active in the local construction industry (from owner/occupiers themselves, unskilled and skilled labour to material transporters, suppliers and producers), and their knowledge and skills, make up the bulk of the rural housing capacity in Bangladesh today.

In addition, the Bangladesh government runs several housing programs for the poor and the landless, such as the Cluster Village approach, the Asrayan program for the landless and a housing loan scheme initiated by the central bank.

Development and humanitarian agencies are also active in construction of housing for the most vulnerable.

All these actors together present a considerable capacity to be engaged in improving the rural housing stock in Bangladesh.

### 3.2 NATURAL DISASTERS IN MAPS

This will provide valuable information to underpin these Guidelines. Until this is final, here included in the Guidelines are the currently available maps for various disasters that regularly affect Bangladesh.

What becomes clear throughout these maps is that a great majority of Bangladesh is subject to disaster, and most of the time to multiple disasters in the same location.

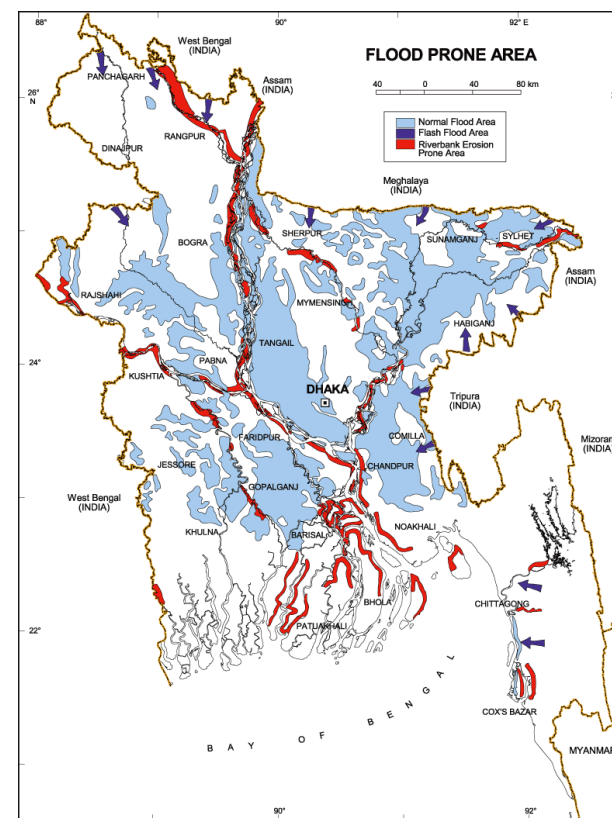

**Map of three types of flooding:** regular flooding, flash flooding and river erosion



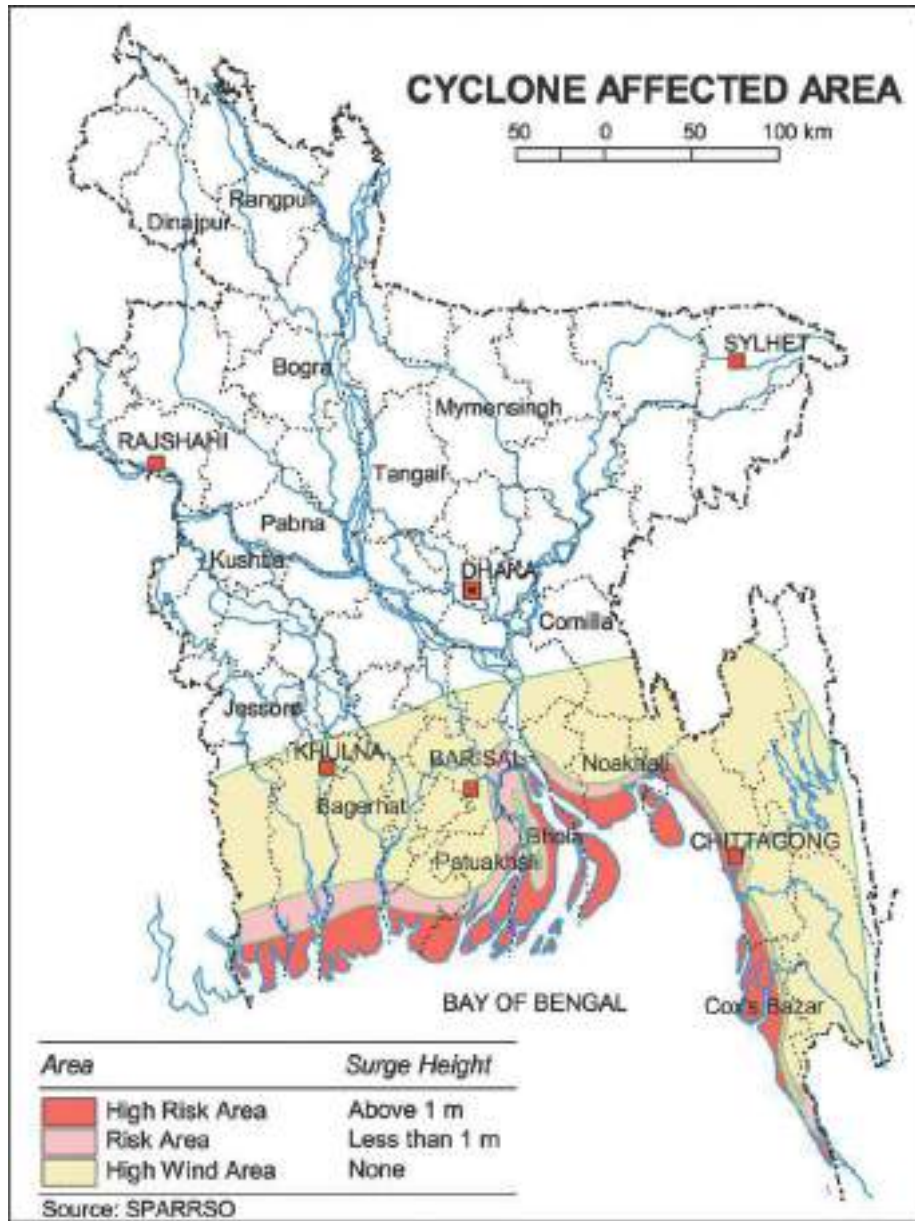

Map of area affected by cyclone, with indication of storm surge risk

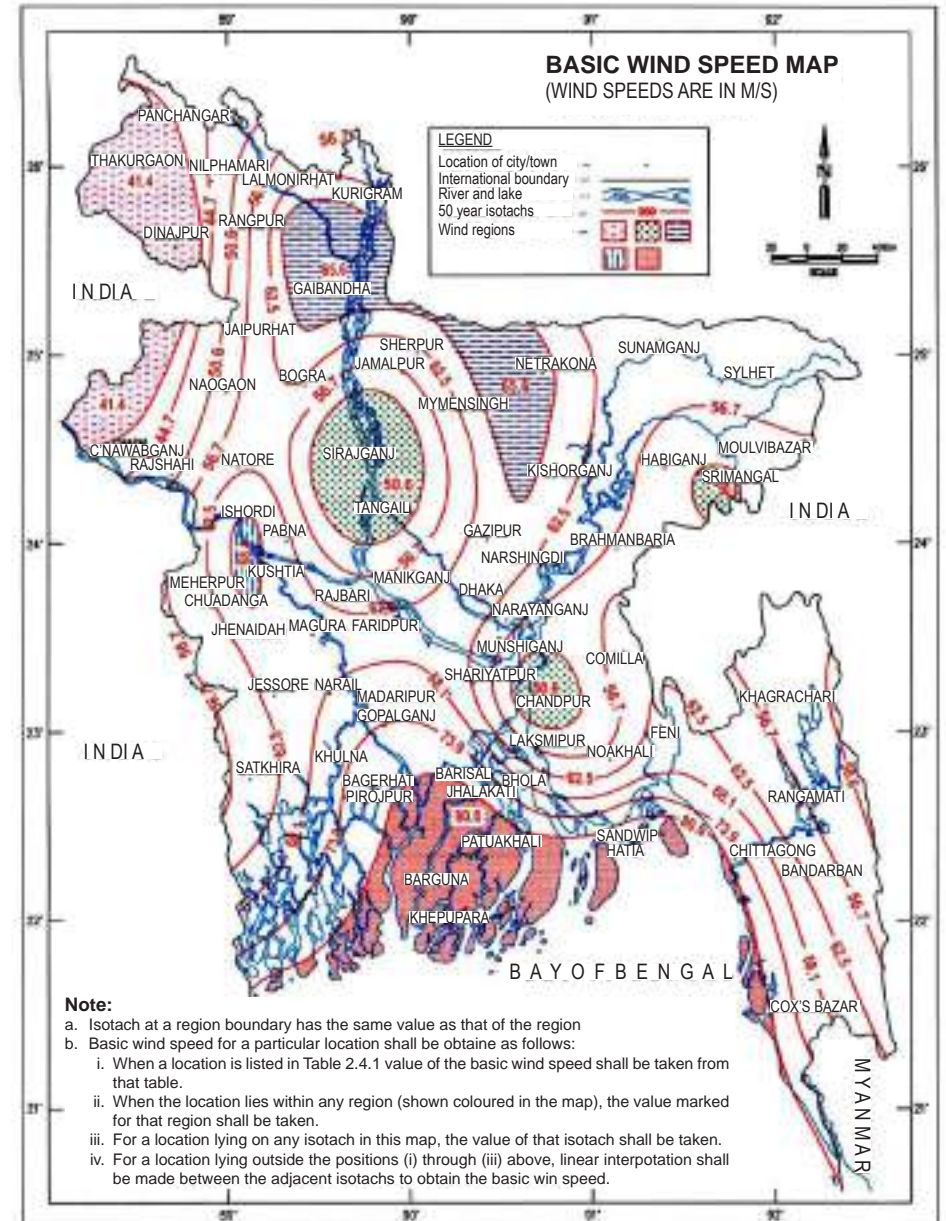

Map of basic wind speed





### 3.3 IMPACT OF CLIMATE CHANGE ON HOUSING

Geographically, Bangladesh is extremely vulnerable to climate changes. Climate changes are expected to increase the intensity and severity of various natural hazards that jeopardise people's lives and negatively impact the socio-economic situation. Recurrent losses of housing and livelihood due to natural hazards such as cyclonic storms, riverine and flash flooding, earthquakes, landslides, a rising sea water level and river erosion which have a massive impact on the rural dwellings, lead to repeated displacement and widespread migration.

The document: 'Planning and Implementation of Post-Sidr Housing Recovery: Practice, Lessons and Future Implications, Recovery Framework Case Study'<sup>1</sup> states:

'Since 1970, on a yearly basis, hazards ranging from floods and cyclones to tornadoes and river erosion have been responsible for fully damaging approximately 300,000 houses and partially damaging about 500,000 houses. A conservative estimate of the Government of Bangladesh (GoB, 2011), puts the damage caused by five major disasters since 1998 at around 15 percent of GDP. Collectively, half of this economic damage has been caused in the housing sector. The houses of the poor sustain the maximum disaster losses.'

<sup>1</sup> Planning and Implementation of Post-Sidr Housing Recovery: Practice, Lessons and Future Implications, Recovery Framework Case Study', Conference Version, GFDRR, World Bank Group, EC, UNDP, September 2014, Bangladesh

These vulnerabilities are compounded by the absence of guidelines, standards or procedures that could help lead the housing and settlement construction in rural areas towards sustainability and resilience. This confirms the major need and requirement for National Guidelines to improve rural housing, with an aim to reduce the effects and impacts of natural disasters.

### 3.4 NATURAL DISASTERS IN NUMBERS

Research conducted by the Centre of Research on the Epidemiology of Disasters (CRED)<sup>2</sup> known as the International Disaster Database EM-DAT gives an overall review of the total number of affected inhabitants per year and per type of disaster for the last 35 years, ranging from 1980 to 2014. Some astonishing facts:

- ▶ In 27 years out of the 35 years, more than 1 million people were affected by natural disaster;

- ▶ In 16 years out of the 35 years, all types of flooding affected more than 1 million people;
- ▶ Only in 3 years were there less than 100,000 affected by some type of flooding;
- ▶ In 9 years out of the 35 years, cyclonic storms as well have affected more than 1 million people;

Moreover, 75 million people were directly affected by natural disasters between 2000 and 2013 with economic damage of USD 10.8 billion.

<sup>2</sup> Source: EM-DAT: The OFDA/CRED International Disaster Database – [www.emdat.be](http://www.emdat.be), Université Catholique de Louvain, Brussels (Belgium)





Household damaged by storm

## CHAPTER FOUR

# POLICY FRAMEWORK OF THE GUIDELINES

Housing impacts on all aspects of living. Rural housing in disaster-prone areas is thus touched upon by many different planning and policy documents of the Government, dealing with sectors such as water resources, disaster management, rural poverty alleviation, local government, social welfare, land policies, forestry and environment, infrastructure and public works, climate change, specific regional policies and development plans etc.

In fact, all Ministries of the Government have a stake in rural housing. To draw out all the policies and plans that are relevant to rural housing in disaster prone areas in Bangladesh falls outside of the scope of these Guidelines. Three sets of policies however are of particular importance for these Guidelines: the housing, disaster management and rural development policies. These Guidelines are developed within the framework these policies offer.

### 4.1 THE DISASTER MANAGEMENT ACT

Disaster management and risk reduction has become one of the major concerns for the government of

Bangladesh because of the country's extreme vulnerability to natural hazards. Under this ministry, the following actions were undertaken:

The Disaster Management Act came into existence in 2012 to coordinate disaster management activities and to formulate rules to build up infrastructure of effective disaster management to fight all types of disaster.

The Department of Disaster Management was established in November 2012 under the Disaster Management Act. This Department is further responsible for:

- ▶ Reducing the overall vulnerability of different impacts of disasters;
- ▶ Conducting humanitarian assistance programs;
- ▶ Strengthening and coordinating programs undertaken by various government and non-government organizations related to disaster risk reduction and emergency response;

- ▶ Conducting research, organizing workshops and training programs, publishing its reports and documents and providing various policy advisory services to concerned Ministries.

The Standing Orders on Disaster is considered as one of the most important policy frameworks which is prepared with the objective of making concerned persons and authorities understand and aware of their duties and responsibilities regarding disaster management at all levels and accomplishing them. Besides effective response, the document also emphasizes on the importance of community preparedness, hazard identification and mitigation and recovery to address issue of vulnerability. (Ministry of Food and Disaster Management , January 2010)

## 4.2 BANGLADESH CLIMATE CHANGE STRATEGY AND ACTION PLAN, 2009

The Bangladesh Climate Change Strategy and Action Plan is a ten year programme to build the capacity and resilience of the country with the aim to meet the challenge of climate change over the next 20-25 years. The following are the developmental areas under the programme:

- ▶ Food security, social protection and health;
- ▶ Comprehensive disaster management;

- ▶ Infrastructural development;
- ▶ Research and knowledge management;
- ▶ Mitigation and low carbon development;
- ▶ Capacity building and institutional strengthening.
- ▶ (Disaster Management and Relief Division , April 2010)

## 4.3 BANGLADESH NATIONAL BUILDING CODE

The major document regulating the technical aspects of construction in Bangladesh is the Bangladesh National Building Code (BNBC). The BNBC is developed to set minimum technical standards for all 'pucca' construction in Bangladesh; meaning all construction that makes use of materials of long durability such as concrete and brick.

A large portion of the current rural housing stock is however 'kutcha' and 'semi-pucca' housing. Moreover, the BNBC doesn't particularly address post-disaster reconstruction in rural areas, in which a lot of use is made of local materials that are not considered 'pucca'.

Still, for 'pucca' housing techniques and materials proposed in these Guidelines, adherence with the Bangladesh National Building Code is stressed.

*Also in this respect, these Guidelines fill in a gap: these Guidelines address technical aspects of rural housing that is 'kutcha' or 'semi-pucca'.*

## 4.4 RURAL DEVELOPMENT POLICIES

A programme has been dedicated to rural housing development by the National Rural Development Policy of 2001. The policy centres on all activities of rural development with a view of alleviating poverty, improving quality of life of poor and economic development of landless and marginal farmers. The housing section of the policy aims primarily on resettlement of families who become landless, displaced or shelter-less due to natural disasters.



Water pumps and latrines submerged by water

## CHAPTER FIVE

# OTHER IMPORTANT DOCUMENTS

Adequate housing was recognized as part of the right to an adequate standard of living in the 1948 Universal Declaration of Human Rights and in the 1966 International Covenant on Economic, Social and Cultural Rights. Other international human rights treaties have since recognized or referred to the right to adequate housing or some elements of it, such as the protection of one's home and privacy.

### 5.1 UNIVERSAL DECLARATION OF HUMAN RIGHTS

The declaration of human rights is extremely relevant to the National Guidelines because it is the most important international document giving meaning and content to qualitative housing.

The Article 25.1 of the Universal Declaration of Human Rights 1948 states that: "Everyone has the right to a standard of living adequate for the health and well-being of himself and his family, including food, clothing, housing and medical care and necessary social services, and the right to security in the event of unemployment, sickness, disability, widowhood, old age or other lack of livelihood in circumstances beyond his control."

### 5.2 SENDAI FRAMEWORK FOR DISASTER RISK REDUCTION 2015-2030

Building on the Hyogo Framework for Action, the Sendai Framework for Disaster Risk Reduction 2015-2030<sup>1</sup> aims to achieve "The substantial reduction of disaster risk and losses in lives, livelihoods and health and in the economic, physical, social, cultural and environmental assets of persons, businesses, communities and countries" over the next 15 years. Taking into account the experience gained through the implementation of the Hyogo Framework for Action, and in pursuance of the expected outcome and goal, there is a need for focused action within and across sectors by States at local, national, regional and global levels in the following four priority areas<sup>3</sup>: 1. Understanding disaster risk; 2. Strengthening disaster risk governance to manage disaster risk; 3. Investing in disaster risk reduction for resilience; 4. Enhancing disaster preparedness for effective response, and to "Build Back Better" in recovery, rehabilitation and reconstruction.

<sup>3</sup> Sendai Framework for Disaster Risk Reduction 2015-2030

According to Guiding Principles 5, States have to prevent displacement in accordance with their human rights obligation to protect people against known and foreseeable risks for their life, limb, and health. Much of the Sendai Framework deals with preventing natural and other hazards becoming disasters by reducing associated risks. In this context, the Framework encourages States to adopt, at national and local levels, “policies and programs addressing disaster-induced human mobility to strengthen the resilience of affected people and that of host communities as per national laws and circumstances.” The mention of host communities is very important as they are affected by displacement, too. Finally, displaced persons in need of durable solutions may profit from the call to integrate

“temporary settlements for persons displaced by disaster” into post-disaster recovery.

### 5.3 SPHERE HANDBOOK

The Sphere Handbook puts the right of disaster-affected populations to live with dignity, and to protection and assistance at the center of humanitarian action. It promotes the active participation of affected populations as well as of local and national authorities, and is used to negotiate humanitarian space and resources with authorities in disaster-preparedness work.

### 5.4 POLICY PAPER 10 – NATIONAL HOUSING POLICY

Expansion of housing opportunities will support the achievement of SDGs, especially SDG Housing Target 11.1, but larger SDGs of poverty alleviation, health, economic development, social cohesion, gender equality and environmental sustainability. This Policy Unit (PU) urges all United Nations (UN) member states to prioritize housing as one of the highest priorities in their government agenda, and to strengthen the institutional capacity of their housing departments to achieve ambitious goals, in collaboration with civil society, donor, and private sector partners.

## CHAPTER SIX

# BUILDING HOUSING CAPACITY

### 6.1 COORDINATION AND USE OF EXISTING RESOURCES

These National Guidelines for rural housing in Bangladesh promote that the best possible strategy to ensure a substantial and consistent improvement

of the rural housing stock in Bangladesh is the optimal use of all available resources.

Resources	Description
People	It includes owners, communities, construction professionals, managers and policy makers to take up their role of improving the rural housing stock in line with their respective experience and expertise.
Skills	It includes local construction labour skills to material production and supply, architecture and engineering practice and research, social mobilization and communication skills and governance and coordination: a broad skill set like this is needed to improve the rural housing stock of Bangladesh
Knowledge	From the knowledge inherent in traditional building cultures to the practical knowledge of housing implementers in the field along with the more theoretical knowledge of research and teaching institutions
Funds	This includes the savings or lending that owners/occupiers take on for their housing, the financial support offered by government and the financial contributions of national and international donors. Proper and effective utilization of all available funds, on all levels, complements the optimal use of people, skills and knowledge.
Materials	From home-grown materials to materials available on the local markets, newly introduced materials or materials in development.
Land	The high population and the fierce competition for land between different uses and the growing urbanization, all require that land is to be used optimally, in coherence with what is stipulated in respective Policies.

Coordination will be the key to optimal utilisation of resources. All these resources will have to be effectively and efficiently utilised and coordinated to ensure the best result and overall development of the situation. Unified messages, training material and

management arrangements need to be developed to ensure maintenance of basic standards as well as equity in coverage. (Ministry of Disaster Management and Relief)



Oval shaped Cluster Village, built by Friendship on a raised plinth



## CHAPTER SEVEN

# HOW TO USE THESE GUIDELINES

### 7.1 ADEQUATE HOUSING END EMERGENCY SHELTERING

The most vulnerable people at present occupy low quality “kutcha” housing, or can, after disaster, only afford to rebuild a “kutcha” house. Support from housing actors should be focused at these most vulnerable, to redesign and reinforce their kutcha houses to make them more adequate and safe to resist hazard impacts, or to ensure that after disaster they can recover safe, healthy and dignified housing.

Emergency sheltering is addressed in these guidelines in full support of the government’s policy to limit the timespan as well as the funding dedicated to the emergency sheltering to the essential minimum that is protecting individuals from the open sky in the immediate aftermath of disaster. The recommendation is that the larger part of available funding should from the beginning be addressed towards increasing long term resilience of the rural housing stock, towards a safe and durable living environment for all.

### 7.2 PRESCRIPTIVE AND FLEXIBLE GUIDELINES, COMPLIANCE MECHANISM

Prescriptive: ‘MINIMUM STANDARDS’: these minimum standards, to be adhered to by all actors, ensure that a minimum level of quality is reached in all emergency sheltering and housing projects pre and post disaster.

Flexible: ‘HOUSE DESIGNS’: the housing designs are meant as a source of inspiration. These National Guidelines open the choice between different housing designs, responding to specific local needs and opportunities as discussed with communities and households, and in accordance with specific working methods of external agencies.

The compliance mechanism of these Guidelines foresees that:

Model housing designs can be taken from these National Guidelines, and should be adapted by house owners or external agencies to fit each specific situation;



All final housing designs need to comply with the minimum standards.

- ▶ Set out in these National Guidelines; for each specific combination of hazards, and different types of techniques and materials used;
- ▶ The process by which external agencies implement housing projects is regulated by these guidelines, to ensure that the long term profit of such housing projects is maximized for all involved.

### 7.3 AWARENESS RAISING AND CAPACITY BUILDING NEEDS

For these Guidelines to take full effect and to render them operational, awareness raising and capacity building is needed on several levels and with all stakeholders in rural housing such as donors, agencies, government, research institutions and others. Stakeholders involved in the consultation process have all confirmed their willingness to support capacity building in line with the guidelines according to their possibilities and area of intervention.

### 7.4 OVERVIEW OF STANDARDS

Types of standard	Description
Minimum standards for adequate housing	These set the standards for any house to classify as a safe, healthy and dignified living environment
Minimum standards for implementing agencies	These standards stipulate how external agencies are to conduct the process of implementing a housing project and emergency sheltering to maximize the long term profit for the affected population
Minimum technical standards for emergency sheltering	These standards set out the options for material support that can be provided immediately after disaster to protect affected populations from the open sky
Minimum technical standards for safer housing	These standards set the technical requirements of safer housing for different hazards and different materials and techniques used

### 7.5 MONITORING AND QUALITY ASSURANCE

The consolidation of existing expertise and experience in these Guidelines is as such a challenge, a first step that can be expanded upon. Elements in the standards that are currently not well practiced or known in housing projects can be deepened further for example, such as after action reviews or systematic monitoring and evaluation. The respective department/organization will introduce appropriate monitoring mechanism for quality assurance.

(Local) government can use the information in these guidelines to take on a more pro-active role in building better: the designs and standards can be translated into field documents and awareness raising and capacity building tools. Once they are better aware of the national guidelines for housing in rural areas, they can also be engaged more in the preparation and response to disasters, by identifying what resources can be mobilized for (re) construction, (pre-) identifying pockets of extremely exposed households etc.

Other Ministries are to be made aware of these guidelines so that coherence can be sought with other issues closely linked to housing, such as the management of forests in relation to harvesting wood and bamboo for house construction or making lands available to households that are landless and/or displaced.

Coordination platforms so that coordination can be informed by these commonly agreed standards; so that the collective actions of different actors can be rendered more concerted, efficient and effective.

Rural communities are to be made aware of these Guidelines through local agencies and government, so that they can take on more ownership and leadership over their own housing situation, be it by taking recommendations for building better, or by being better aware of what they can expect from agencies implementing housing projects in their communities.

Research institutions are to be made aware of these Guidelines so that they can take them as a starting point for further research and development. The Guidelines set a challenge for development and introduction of innovative materials into the local construction industry for example. Another example is that research institutions could work on creating

and 'evidence base' for different approaches to community participation, and the use of local materials and labour. Perhaps such 'evidence base' can inform a review of these Guidelines in five years of time or before.

To reach these needs, the adoption of these Guidelines is to be followed up by:

- ▶ An awareness raising campaign on several levels, through various media, meetings and presentations, to get the Guidelines known by all relevant stakeholders;
- ▶ Development of appropriate tools to foster awareness and build capacity, such as key-messages around building back better for the rural population, training modules for local government, introductory presentations for continued coordination with donors, between agencies and different Ministries etc.

Such further deepening and detailing of approaches, house designs, new materials and techniques etc. requires an updating of these Guidelines in 5 years' time. Thereto, it is advised to put in place a monitoring and evaluation mechanism to capture the impact of the Guidelines over the first five years of its implementation.

## 7.6 LIMITATIONS OF THE GUIDELINES

A number of topics are very closely related to housing in rural areas but fall outside of the scope of these guidelines:

- ▶ Infrastructure challenges, including the construction and maintenance of

embankments, cyclone shelters and other protection and mitigation measures like the promotion of protective vegetation along the coast to break the impact of cyclones in areas vulnerable to cyclones etc.

- ▶ Water and sanitation solutions that should by default are part of a housing solution. Expert knowledge on technicalities of implementation already exists.
- ▶ The link of housing to livelihoods
- ▶ Other elements of the house: protection of assets, kitchen, solutions for keeping cattle safe during disasters etc.
- ▶ Standards for other rural constructions such as schools and cyclone shelters;
- ▶ Housing in semi-urban areas / the growing urban fringes;
- ▶ Implementation methodologies for housing projects, such as organizing community consultations, cash and/or voucher distributions, technical awareness raising campaigns etc.: expert knowledge regarding implementation methodologies already exists elsewhere;
- ▶ Funding mechanisms for rural housing;
- ▶ Land management issues;
- ▶ Construction materials supply chain management issues.

This Guideline focuses primarily on the process, material and technical aspects of individual housing solutions.

A whole range of topics with regards to rural housing in disaster prone areas can be developed further using these National Guidelines as starting point. For example, owner or community driven housing can be developed further and adapted to the context. Also, new techniques and materials may become available that fundamentally change house design options for rural areas.

Furthermore, the socio-economic situation is subject to change, and the full impact of climate change is not yet known. In future, an additional focus may need to be added to the Guidelines to address relocation projects, or the development of the fringes of cities, where urban sprawl is growing often in hazardous locations and might need multi-story solutions.

To further deepen and detail approaches, house designs, new materials and techniques etc. will require an updating of these Guidelines within maximum 5 years' time and an interim review may take place considering to respond evolving needs & demands as appropriate.

It will be advised to set up a monitoring and evaluation mechanism in order to capture the impact of the Guidelines over the first five years of its implementation.



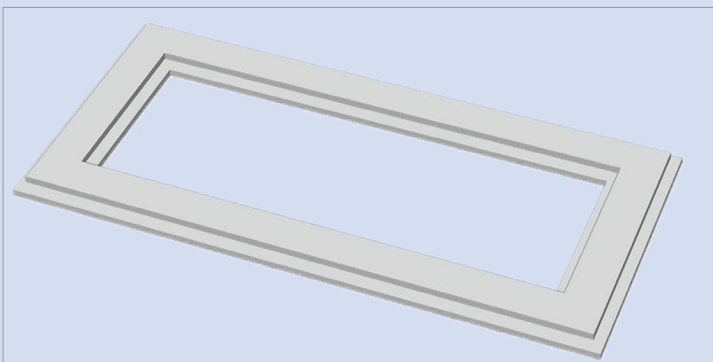

PART TWO

# MINIMUM STANDARDS



## CHAPTER ONE

# MINIMUM STANDARDS FOR ADEQUATE HOUSING

The right to adequate housing is stipulated in the Universal Declaration of Human Rights. The International Covenant on Economic, Social and Cultural Rights (ICESCR), 1966, specifies what adequate housing means, in seven aspects: legal security of tenure; availability of services, materials, facilities and infrastructure; affordability; habitability; accessibility; cultural adequacy and location. These have been taken (combined with earlier work conducted by the Shelter Cluster in Bangladesh) as basis to formulate the following minimum standards for adequate housing in Bangladesh:

These standards are to be applied to in all housing construction in rural areas. They can also be used to evaluate a house once it is built and inhabited.

Standards for Adequate Housing in Bangladesh	
Standard 1	<p>Security of tenure is guaranteed for a set period of time of at least 30 years:</p> <ul style="list-style-type: none"> <li>▪ The current situation of tenure is to be assessed;</li> <li>▪ Where security of tenure is absent, it needs to be obtained for at least 30 years (through relocation, owner deeds or rental agreements within the means of the household, or other);</li> <li>▪ Proof and documentation of security of tenure is to be provided to the inhabitants.</li> </ul>
Standard 2	<p>Access to safe water and sanitation solutions are to be provided:</p> <ul style="list-style-type: none"> <li>▪ One up to the standard toilet is to be provided per household;</li> <li>▪ Access to ample safe water is to be provided within 300 meter from the house site;</li> <li>▪ The construction of toilet and water supply solutions needs to respect the same hazard resilience measures as applied in housing.</li> </ul>

Standards for Adequate Housing in Bangladesh	
Standard 3	<p>All housing is built with materials and techniques that allow easy maintenance, repair and duplication:</p> <ul style="list-style-type: none"> <li>Preference to local, well-known and available materials;</li> <li>Focus on local techniques and tricks, and the improvement thereof;</li> <li>Accompany introduction of new materials and techniques with extensive training and follow-up;</li> </ul>
	<ul style="list-style-type: none"> <li>Look into options to produce new materials locally;</li> <li>Expected repair and maintenance cost and time must remain within the budget of the household and limited to what households can do in combination with their other activities.</li> </ul>
Standard 4	<p>All housing and sites are adapted to the local hazard profile to resist recurrent disasters over 30 years:</p> <ul style="list-style-type: none"> <li>For the implementation area: identify threats that sites and houses are exposed to, establish which hazard profile is to be taken into account in the design of the house;</li> <li>For the individual house/site: identify which additional location/site specific threats are to be taken into account: lack of protective vegetation, proximity to a river edge, communal plinth of insufficient height etc.;</li> <li>All houses are built in coherence with the minimum technical standards set out in these guidelines for the different hazards.</li> </ul>

Standards for Adequate Housing in Bangladesh	
Standard 5	<p>All housing offers a comfortable and healthy internal climate:</p> <ul style="list-style-type: none"> <li>The dimension of the smallest house module should not be lesser than 10'-0"X12'-0" for a family of 2-3 members. (min Approx. 3.6 sqm per person)</li> <li>Cross-ventilation is provided by placing at least 2 windows on opposite sides of the house in the main room, and at least one additional window in each additional space;</li> <li>Windows are all fitted with a system for partial or full blinding, in accordance with local practices;</li> <li>Additional ventilation openings are foreseen in cooking areas, and under the roof in areas where heat builds up inside the house.</li> </ul>
Standard 6	<p>All housing is adapted to special and specific needs of its inhabitants:</p> <ul style="list-style-type: none"> <li>5 to 10% of the budget for the house is allocated to adapt standard house designs to the specific needs of individual households (access ramp, additional internal separations, storage room or other) and takes into account the varying needs of different members of a household (female and male, of all ages);</li> <li>This may also be spent on site organisation, to be decided in discussion with the individual household.</li> </ul>

Standards for Adequate Housing in Bangladesh	
Standard 7	<p>All housing is functional, culturally appropriate and adaptable:</p> <ul style="list-style-type: none"> <li>If necessary, each house should be provided with two doors; one as the main entry others as secondary exit.</li> <li>In discussion with communities and households standard designs are adapted to cultural practices;</li> <li>If uncommon types of houses are built, awareness is to be raised as to why, the community's acceptance is to be obtained, and additional training is to be conducted for repair and maintenance;</li> <li>The house is adapted to particular functional needs of the household (see also Minimum Standard 6);</li> <li>Each house is built so that it can be easily adapted or expanded upon (easy to make qualitative connections, preference of local materials etc.);</li> <li>Training is to be provided as to how safe extensions and adaptations can be made.</li> </ul>
Standard 8	<p>All housing should be situated as close as possible to employment and education opportunities, medical and other social services:</p> <ul style="list-style-type: none"> <li>Accessibility to housing sites is to be guaranteed;</li> <li>Especially for relocation projects, sites are to be chosen that allow households to access livelihood opportunities and services.</li> </ul>



## CHAPTER TWO

# MINIMUM STANDARDS FOR IMPLEMENTING AGENCIES

For agency-supported housing, specific standards are formulated to provide guidance in the process of implementing a housing project.

### 2.1 TYPES OF HOUSING PROJECTS IMPLEMENTED BY EXTERNAL AGENCIES

Most agencies focus on reconstruction of complete houses after disaster. These Guidelines however identify 6 different types of shelter or housing projects that external agencies can undertake, and that contribute to an improved rural housing stock in Bangladesh\*:

Project type	Timing of implementation	Durability	Target group
Project Type 1: Emergency sheltering	Immediately after disaster	Allows the population to bridge the gap between the disaster and the opportunity to access a durable solution	Households not protected from the open sky after a disaster, regardless of their land occupancy status
Project Type 2: Upgrade/ repair for greater resilience	Implemented irrespective of disaster (upgrade) and after disaster (repair)	After upgrade or repair, houses adhere to the minimum technical standards, needing only maintenance within the means of the inhabitants	Households that occupy substandard housing or whose houses have been damaged by disaster, and are legal land occupiers or owners
Project Type 3: Housing on uncertain lands	Implemented irrespective of disaster and in the recovery phase after disaster	Houses up to the minimum technical standards, needing only maintenance within the means of the inhabitants	Households that live on lands that shift due to river erosion

Project type	Timing of implementation	Durability	Target group
Project Type 4: Relocation	Implemented irrespective of disasters and in the recovery phase after disaster	Houses up to the minimum technical standards, needing only maintenance within the means of the inhabitants	Households that hold no legal occupancy title for the land they live on
Project Type 5: Reconstruction	Implemented in the recovery phase after disaster	Houses up to the minimum technical standards, needing only maintenance within the means of the inhabitants	Households whose house has been destroyed by disaster and are legal owners/ occupiers of the land they stay on
Project type 6: CBDRR projects focusing on shelter and settlements (partially or exclusively)	Implemented irrespective of disaster and in the recovery phase after disaster (focused on awareness raising and technical support, self-construction)	Key messages are in coherence with the minimum technical standards	All rural communities living in disaster prone areas

\* (The implementation methods applied for these different types of projects fall outside the scope of these guidelines.)

## 2.2 UNDERLYING PRINCIPLES

There are 5 principles that should underpin all agency supported housing projects, in coherence with the role they have in improving the rural housing stock in Bangladesh:

### Principle 1:

All housing projects are to complement and build further on the self-coping capacity of the targeted population, and strengthen that self-coping capacity.

### Principle 2:

For housing projects supported by external agencies, efforts need to be made for the ownership over the project to lie primarily with the targeted communities and households.

### Principle 3:

The utmost vulnerable are to be targeted: the households that are now living in sub-standard

conditions or have no means to recover a safe, healthy and dignified living environment after the impact of disaster.

### Principle 4:

Equity of support is to be sought in every housing project, in coherence with agreed beneficiary selection criteria, as to respect fairness towards targeted and affected populations, and avoid tensions.

### Principle 5:

All housing projects are to seek a maximum possible gain in resilience of communities and households towards future disaster.

*These principles are to be applied to by all housing actors undertaking housing projects in rural areas.*

## 2.3 MINIMUM STANDARDS FOR IMPLEMENTING AGENCIES

The Sphere Core Standards describe in detail how agencies can support affected populations, immediately after disaster, in the recovery phase and even in preparation to disaster. These Sphere Core Standards are taken as starting point to formulate the following minimum standards for implementing agencies and combined with earlier work conducted by the Shelter Cluster in Bangladesh:

*These standards are to be applied to by all housing actors undertaking housing projects in rural areas. They can also be used to evaluate projects set up by housing actors.*

Minimum standard for implementing agencies in Bangladesh	
Standard 1	Respect the Sphere Protection Principles: <ul style="list-style-type: none"> <li>▪ Protection Principle 1: Avoid exposing people to further harm as a result of your actions;</li> <li>▪ Protection Principle 2: Ensure people's access to impartial assistance – in proportion to need and without discrimination;</li> <li>▪ Protection Principle 3: Protect people from physical and psychological harm arising from violence and coercion;</li> <li>▪ Protection Principle 4: Assist people to claim their rights, access available remedies and recover from the effects of abuse.</li> </ul>

Standard 2	<p>Put in place community information, feedback and complaint mechanisms:</p> <ul style="list-style-type: none"> <li>▪ Inform communities and households about the housing actor's mandate and project(s), its entitlements and rights, means to access assistance, and progress of the project;</li> <li>▪ Put in place a systematic and transparent mechanism that allows communities to provide regular feedback and influence projects;</li> <li>▪ Put in place a complaint mechanism, open equally to all members of the community, in place throughout the project, with transparent and timely procedures for response and remedial actions.</li> </ul>	Standard 4	<p>Make optimal use of local resources, including materials, skills and knowledge:</p> <ul style="list-style-type: none"> <li>▪ Ensure economic profit, and profit in terms of knowledge creation, remains as much as possible in the targeted communities;</li> <li>▪ If use is made of non-local materials, ensure communities and households are aware of maintenance and repair requirements.</li> </ul>	Standard 6	<p>Base the project on an estimate of the self-coping capacity of communities and households, and the impact of the project on that self-coping capacity, towards greater resilience, and continue collaborative and coordinated assessment throughout the project:</p> <ul style="list-style-type: none"> <li>▪ Assessments are to target at least physical aspects of houses and sites; climate and geological conditions; hazard profiles; the local construction industry; economic, social, vulnerability and environmental aspects in relation to housing; risks to the project;</li> <li>▪ Engage communities, households, local government, community leaders, actors of the local construction industry (traders, labor), social groups, all age groups, specifically vulnerable groups, in continued assessment;</li> <li>▪ Participate in coordinated assessments with other housing actors, share assessment outcomes;</li> <li>▪ Triangulate assessment data;</li> <li>▪ Ensure projects are informed by assessment outcomes.</li> </ul>
Standard 3	<p>Maximize community involvement, involvement of beneficiary households and specifically vulnerable groups and individuals:</p> <ul style="list-style-type: none"> <li>▪ Form a Project Committee, through open elections, with at least 30% female representation, guaranteed representation of all cultural groups and people with particular vulnerabilities, to take ownership and local leadership over the housing project;</li> <li>▪ Collaborate with and support the Project Committee to identify the most vulnerable in the community in an open and fair manner;</li> <li>▪ Engage the Project Committee, and through them the community, in project activities such as assessment, construction management, M&amp;E, coordination with local government and follow-up after completion;</li> <li>▪ Consult individual households about their particular needs impacting on their house design and site organisation;</li> <li>▪ Ensure any additional vulnerability issues inform the housing project, through the collaboration with the Project Committee and consultation of individual households.</li> </ul>	Standard 5	<p>Ensure coordination and collaboration on the local and national level, and contribute to the overall knowledge and capacity creation in housing:</p> <ul style="list-style-type: none"> <li>▪ Consult regularly with the Union Chairman, Union Members and the Local Government Engineer;</li> <li>▪ Regularly share insightful and updated information regarding the project with the Union Parishad and in applicable local and national coordination mechanisms;</li> <li>▪ Coordinate locally with other agencies implementing housing projects to ensure local equity of assistance;</li> <li>▪ Coordinate nationally: search to establish a timely, clear division of labour and responsibility, gauge the extent to which needs are being met collectively, and address gaps in coverage and quality;</li> <li>▪ Ensure that lessons learned and identified gaps contribute to the overall knowledge and capacity creation in housing.</li> </ul>	Standard 7	<p>Select implementation areas in a coordinated manner; improve collective coverage and reduce duplication:</p> <ul style="list-style-type: none"> <li>▪ Areas with the greatest need are given preference;</li> <li>▪ Prior presence and established working relationships with communities, social groups and local government is preferable;</li> <li>▪ Information is taken from and provided in coordination platforms to seek better coverage of needs and avoid duplication.</li> </ul>



## CHAPTER THREE

# MINIMUM TECHNICAL STANDARDS FOR EMERGENCY SHELTERING

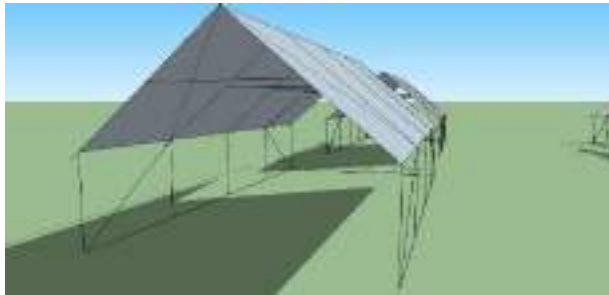
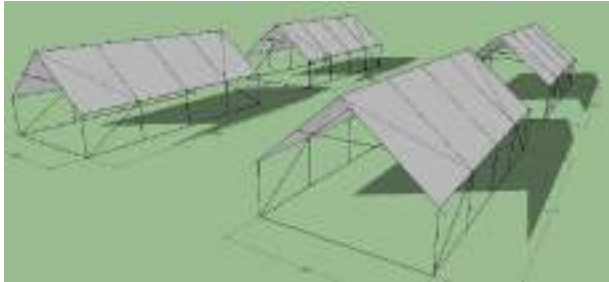

Of all housing project types, Type 1: Emergency shelter provision stands out because of its limited durability linked to its purpose: protecting people from the open sky immediately after disaster.

Protecting people from the open sky doesn't necessarily include building, as people may find refuge with host families, in collective centres etc. These guidelines focus only on the material support options for emergency sheltering. For how to implement host family programs, organize collective centres or other non-material support options, separate expert guidance exists.

These standards are based on the Shelter Standards and Guidelines developed by the Bangladesh Shelter Cluster.

### 3.1 MATERIAL SUPPORT OPTIONS IN EMERGENCIES

The standard emergency sheltering support option in Bangladesh is to support self-building by distribution of materials, tools, cash and providing technical support. Only in exceptional cases it is necessary to actually build emergency shelters for affected households. Based on the recommendations of the Shelter Cluster in Bangladesh, the following material support options in emergency sheltering have been identified:

MATERIAL SOLUTIONS FOR DISPLACED					
Emergency sheltering scenarios	NFI kit	Shelter kit Landless	Shelter kit Fully D.	Shelter kit Partially D.	Emergency Shelter
households staying with <b>host families</b>	x	0	0	0	0
households staying in <b>collective centres</b>	x	0	0	0	0
households staying in <b>formal camps</b>	x	0	0	0	x
households that set-up an <b>informal camp</b> themselves	x	x	0	0	0

MATERIAL SOLUTIONS FOR NON-DISPLACED					
Emergency sheltering scenarios	NFI kit	Shelter kit Landless	Shelter kit Fully D.	Shelter kit Partially D.	Emergency Shelter
households occupying their <b>partially damaged</b> house on the family plot	x	0	0	x	0
households occupying their <b>fully damaged</b> house on the family plot	x	0	x	0	0
households that <b>self-settled</b> on embankments etc., not on family plot	x	x	0	0	0

	NFI kit	Shelter kit Landless	Shelter kit Fully damaged	Shelter kit Partially damaged	Emergency Shelter
APPROX. COST IN BDT*	3.000	6.000	6.000	4.400	6.000

The approximate cost of the different types of shelter kits is (\*estimated cost at time of publication of this document, to review in light of price in- or deflation):

### 3.2 COMPOSITION OF THE NFI KIT

Fire / light		quantity
Candle	height 6 to 6.4 inch, diameter 0.7 inch, burning life more than 3 hours	12
Match box	branded product, carbonized 100% safety match, 60 +/-2 stick per box, packed in water resistant bag	6
Textiles		
Blanket	woven, 80% wool, 1.5 by 2m, high thermal resistance	1
Clothes	1 pc sharee for women, 1 pc lungi for men per pack	2
Kitchen utensils		
Aluminium saucepans (paatil) with lids	1 Pc. Big Size with lid: 11 No. make (Rice)	2
	<u>Material:</u> Aluminium; <u>Weight:</u> 450 gr (without lid)	
	<u>Top Dia:</u> 9.0 inch; <u>Height:</u> 7.70 inch.	
	1 Pc. Small Size with lid: 10 No. make (Curry) ;	
	<u>Material:</u> Aluminium; <u>Weight:</u> 300 gr (without lid);	
	<u>Top Dia:</u> 9.4 inch; <u>Height:</u> 5.5 inch.	
	<u>Lid weight:</u> 100 gr; <u>Lid dia:</u> 8.7 inch (rice), 8.7 inch (curry)	
	<u>Finish:</u> No sharp edges	

Kitchen utensils		
Steel bowl	<u>Material:</u> Stainless steel; <u>Weight:</u> 100 gr/pcs	1
	<u>Top dia:</u> 6.5 inch; <u>Height:</u> 1.75 inch; <u>Finish:</u> No sharp edges	
Plastic mug	<u>Material:</u> Food grade quality plastic. 100 % Poly Propylene unbreakable, flexible and injection moulded <u>Capacity:</u> 2 liters; <u>Weight:</u> 100 gr/pcs <u>Top dia:</u> 5.9 inch; <u>Height:</u> 6.45 inch. <u>Finish:</u> No sharp edges	2
Steel cups	<u>Material:</u> Stainless steel; <u>Weight:</u> 50 gr/pcs <u>Top dia:</u> 2.75 inch; <u>Height:</u> 4.4 inch. <u>Finish:</u> No sharp edges	2
Aluminum plates	<u>Material:</u> Aluminum suitable for contact with food <u>Weight:</u> 100 gr/pcs <u>Top Dia:</u> 9.9 inch; <u>Height:</u> 1.3 inch. <u>Finish:</u> No sharp edges	2
Steel spoons	<u>Material:</u> Stainless steel <u>Length:</u> Rice spoon- 11.20 inch; Curry spoon- 11.50 inch; Tea spoon- 5.70 inch. <u>Finish:</u> No sharp edges	3
Aluminum bucket	<u>Material:</u> Aluminum. Heavy duty with handle. <u>Weight:</u> 600 gr/pcs with handle <u>Top Dia:</u> 12.00 inch (inside); <u>Bottom Dia:</u> 7.00 inch (outside), 6.25 inch (inner side) <u>Height:</u> 9.100 inch (Outer), 8.60 inch (inner) <u>Finish:</u> No sharp edges	1



### 3.3 COMPOSITION OF THE SHELTER KITS

Distribution of kits is the standard response to sheltering needs immediately after disaster in Bangladesh. With these kits - including materials, tools, fixings and cash - affected households are capable of protecting themselves from the open sky immediately after disaster. Additionally, community participation is to be organized, so that the most vulnerable are identified and reached, with community support. Also, awareness is to be raised and technical support provided so that optimal use of the kits is made.

#### Flexible kit composition

In these guidelines, 3 different standard kits are proposed: for landless, for fully damaged houses and for partially damaged houses. However, these

kits can be distributed in phases, or in different compositions, according to the actual situation in the disaster affected areas, and following the **advisory of the emergency sheltering coordination mechanisms** in place as to ensure equity in support:

- ▶ If some items cannot be obtained immediately after disaster, or their transport requires too much time in light of the urgency of support, it may be advised to commence with the distribution of tarpaulins and some fixing materials as for example rope and nails, and provide the rest of the kit slightly later;
- ▶ If affected populations prefer to build collectively, material kits can be composed especially for that: the number of tools may be reduced and the amount of materials and fixing materials increased, to be discussed with the targeted communities;
- ▶ The cash component of the kits can be increased, and the material component decreased, if all necessary sheltering items are readily available on the local market in sufficient qualities and quantities, and sufficient awareness exists regarding selection of materials.
- ▶ Redistribution of some materials may be necessary to upgrade the emergency shelters if access to durable housing solutions cannot be obtained. Examples are renewal of tarpaulins if they have suffered too much wear and tear.

		Quantity kit for landless	Quantity kit for fully damaged	Quantity kit for partially damaged
<b>Materials</b>				
Tarpaulin	woven plastic, 4m by 6m, weight 170g/m <sup>2</sup> +/- 5%, plus 10% for the reinforcement bands under ISO 3801	1pc	1pc	1pc
Bamboo	bamboo - sheel borak 15' length, min 9" circumference bottom, min top dia 2", min wall thickness 0.25", dry	4pc	4pc	0
	bamboo - sheel borak 10' length, min 9" circumference bottom, min top dia 2.5", min wall thickness 0.25", dry	10pc	10pc	4pc
<b>Tools</b>				
Cutter	with safety latch, furthermore no specs	1pc	1pc	1pc
Claw hammer	Weight 0.750kg/pc. Replaceable wooden handle. Forged head, not cast.	1pc	1pc	1pc
Hand saw	Total length 750mm, for wood, good quality, tempered, hardened and set teeth. Unbreakable handle. blade covered by protective cardboard	1pc	1pc	1pc
Hoe	head only is 230x175mm, 1.360g in forged steel, supply with varnished hard wood handle length approx. 110-120cm. blade covered by cardboard	0	1pc	0
<b>Fixings</b>				
Rope	Nylon, polyamide (or jute), diameter 6 - 12 mm, braid, 30m, in roll, possibility to untie	1 roll of 30m	1 roll of 30m	1 roll of 30m
Tie wire	diameter 2mm, 5 meters long piece in a roll	6 rolls	6 rolls	3 rolls
Nails	steel galvanized nails, 50mmx2.5mm (2inches), in a sealed bag	1kg	1kg	0.5kg
	steel galvanized nails, 75mmx3mm (3inches), in a sealed bag	1kg	1kg	0.5kg
Mild steel band	on roll, 2m, thickness 2mm	1 roll	1 roll	1 roll

		Quantity kit for landless	Quantity kit for fully damaged	Quantity kit for partially damaged
<b>Other</b>				
Brochure	details of properly fixing tarpaulin and bamboo, inclusion of bracing and tie down, use of anchors	1pc	1pc	1pc
Woven sack	or other packaging material: safe, handy to stock and carry	1pc	1pc	1pc
Cash	for additional materials, transport and/or labour	500BDT	500BDT	500BDT
Approx. cost		6.000 BDT	6.000 BDT	4.400 BDT

In most cases it is not advised to distribute tin sheets (CGI) as emergency sheltering solution, for three reasons:

- ▶ When a structurally sound house is not available, households cannot fix the tin sheets properly, which may pose a hazard in storms and could damage the sheets;
- ▶ When households cannot use the tin sheets immediately, they may sell them off, trade them for lesser quality tin sheets or damage them in storage;
- ▶ The distribution of tin sheets early on during the emergency response reduces substantially the funding remaining for offering durable housing later on in the response.

### 3.4 AWARENESS RAISING AND TECHNICAL SUPPORT

Alongside the distribution of kits, the affected population should be given a minimum of technical support, and awareness is to be raised, about how to most optimally use the materials, tools and fixings of the kits. There are a number of technical issues that need to be clarified through awareness rising and direct technical support offered to the affected population:

<b>Connections and joints</b>	Even in emergency sheltering, double nailing is primordial to ensure a minimum of strength. Metal strapping, tie wiring and rope tying can be used for bamboo connections and to furthermore ensure qualitative connections.
<b>Drainage</b>	Ensure that rain cannot enter the shelter, or can be quickly evacuated in case of heavy rains, by means of slightly elevating or bordering the shelter and organising drainage.

Raising awareness before disaster about safe construction techniques, or training community volunteers in emergency sheltering construction before disaster, may increase the speed and quality of implementation after disaster.

This technical support can be provided with graphic materials and key-messages. It is to be based on techniques that can be easily locally applied, please find examples below:

Key-issues for awareness raising and technical support during emergency sheltering	
<b>Re-use of salvaged materials</b>	Avoid re-use of burnt, decayed, swollen, rotten and broken materials for structural parts of the emergency shelter.
<b>Fixing of tarpaulins</b>	Fix tarpaulins well to increase their lifespan: nail through the reinforced black bands (for IFRC standard Tarp) or use a washer (metal, bottle cap, plastic or other), between the nail and the tarpaulin; foresee sufficient slope for water run-off from roof; folding of edges before fixing, protection slips where rope is tensioned over tarpaulin etc. Include guidance for storage of tin sheets (distance keeper between tin sheets).
<b>Anchoring/ foundation</b>	The emergency shelter is to be fixed/anchored well to the ground, be it by tying to bamboo poles, sufficient pegs, ballast or other locally known practices.
<b>Bracing</b>	The durability safety and living quality of emergency sheltering can be greatly improved by including cross- and diagonal bracing in cyclone area, and corner bracing in non-cyclone area.



### 3.5 DESIGN OF AN EMERGENCY SHELTER

The construction of entire emergency shelters by support agencies or government is only relevant when substantial numbers of people can't self-settle or self-built. This has seldom, or not, been the case in most recent disasters, but may, under the influence of climate change, become necessary

in the decades to come. Substantial numbers of people can become displace when for example large parts of an area remain inundated for several months, if large sections of embankments need to be repaired before water can be evacuated, or people are evacuated out of urban areas until those are recovered.

These Guidelines include 2 indicative / example designs for individual household's emergency shelters that can be expanded to collective centres. These shelters can be set up within a matter of hours using local materials and techniques: bamboo poles tied together, with a roof covering of tarpaulin.

#### DESIGN 1

This emergency shelter offers approximately 3,6m<sup>2</sup> of covered living space per person, counting households with 5 family members.

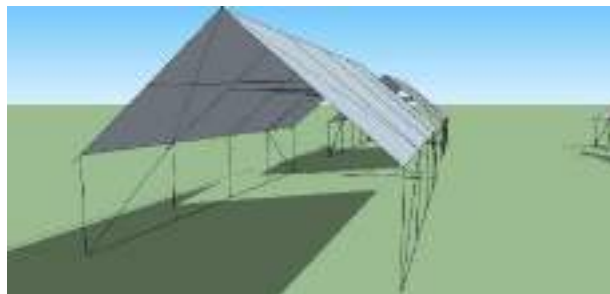

#### Usage of materials

Number and sizes of bamboo poles used in this emergency sheltering design

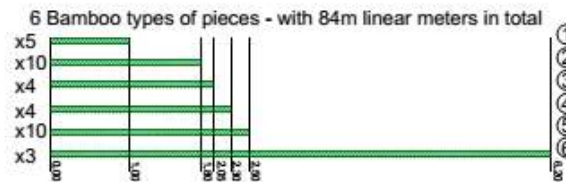

10 foundation holes are to be dug, representing a total digging

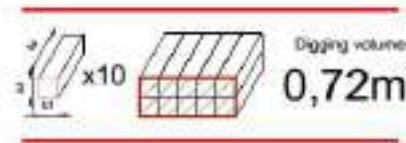

volume of 0.73m

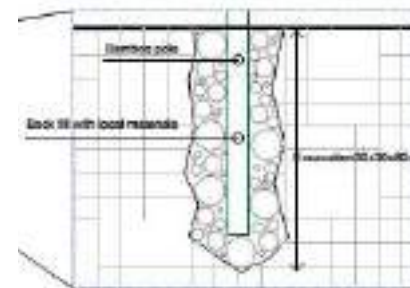

2 tarpaulins are used: one piece for the roof, and a second for wall finishing

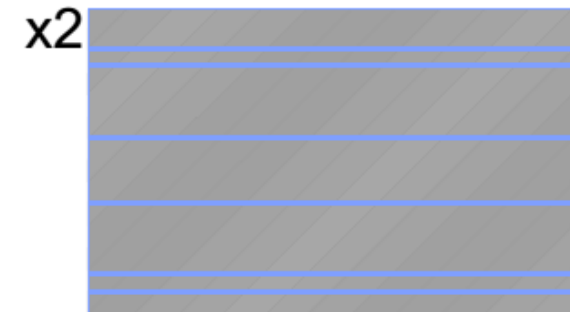

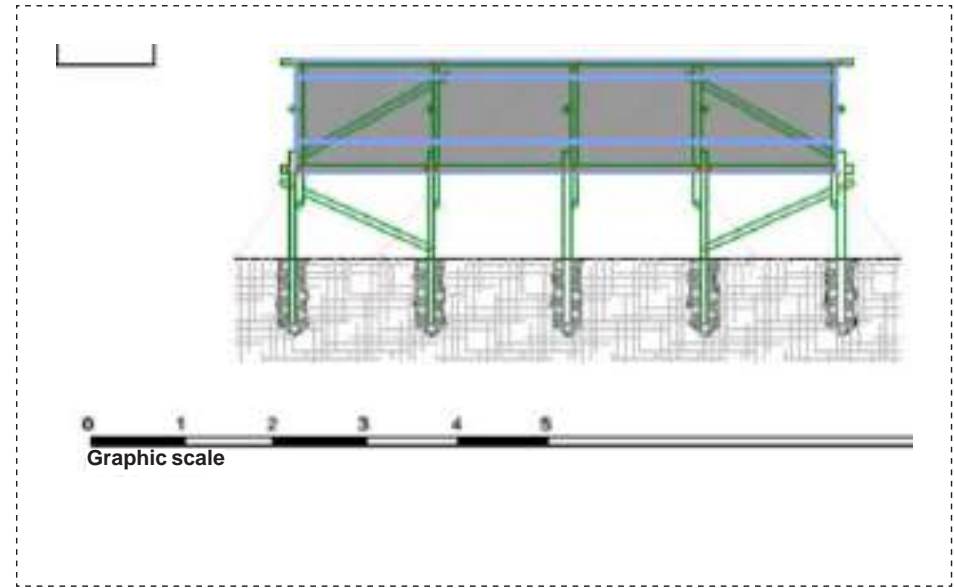
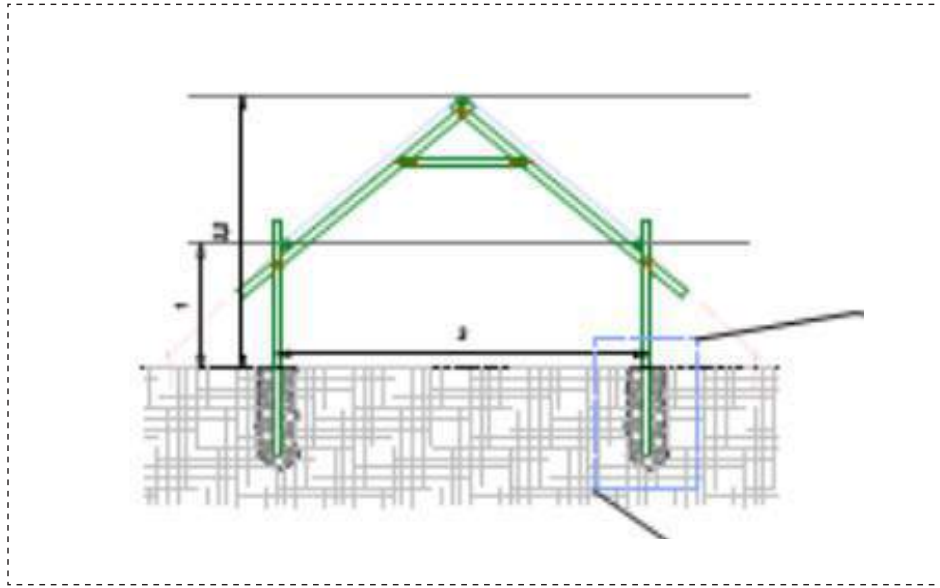

## DETAILS OF BAMBOO CONNECTION

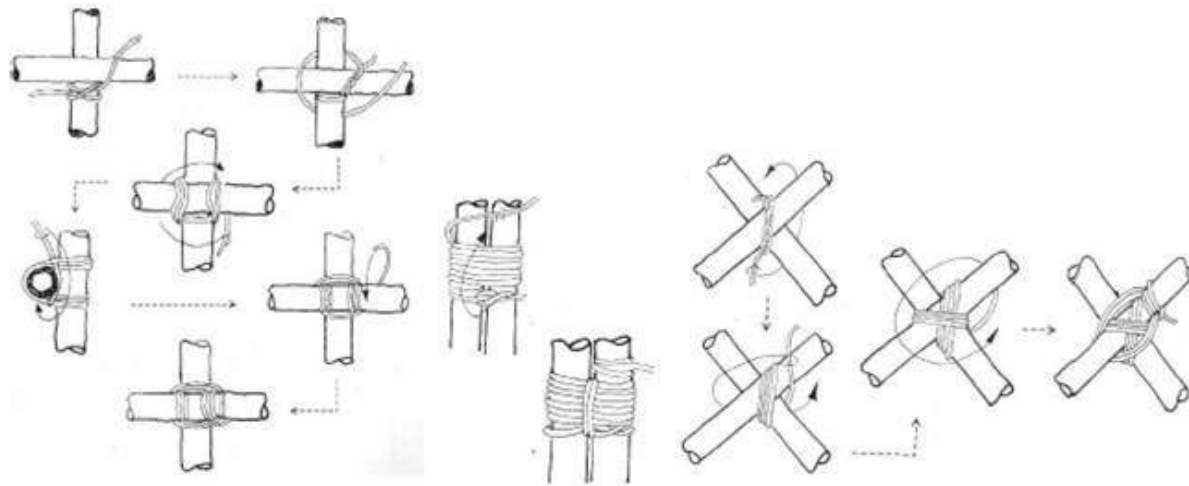



## Right: Plan view and construction steps

**Step 1:** set out the measurements on the site, place the 10 columns into the ground, backfill the foundation holes

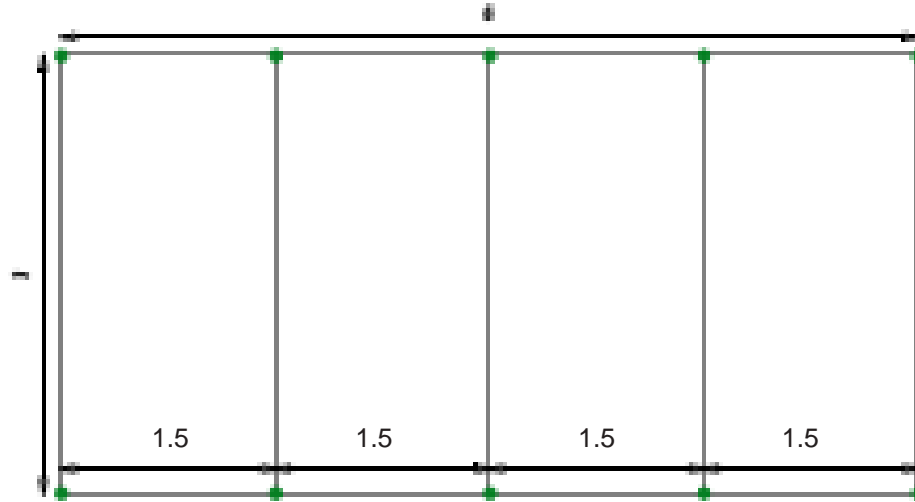

**Step 2:** add ring beam and roof structure

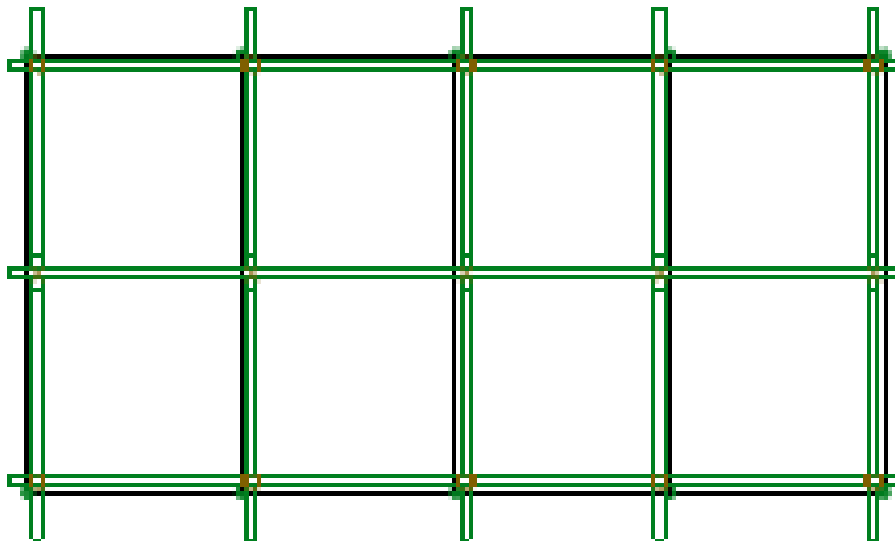

**Step 3:** add cross bracing in the roof and the side walls

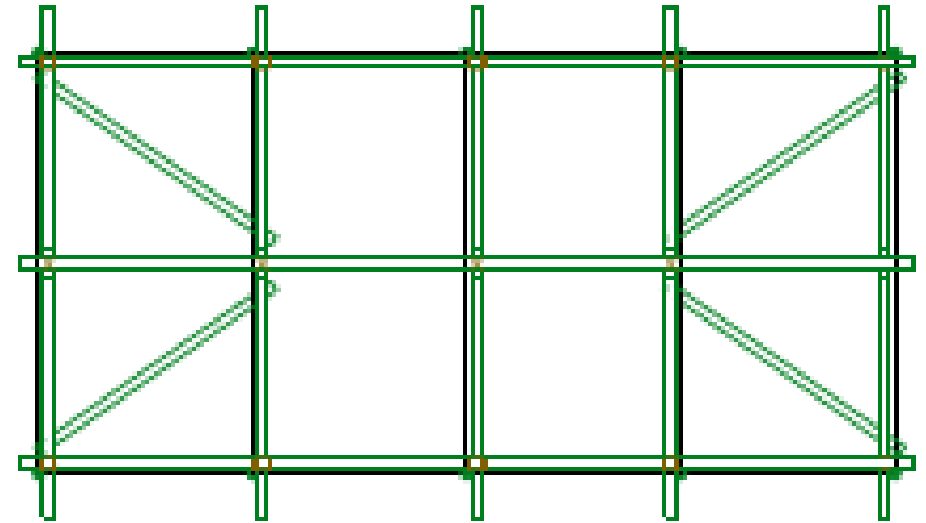

**Step 4:** fix tarpaulins and tension with ropes to tie the entire structure additionally to the ground

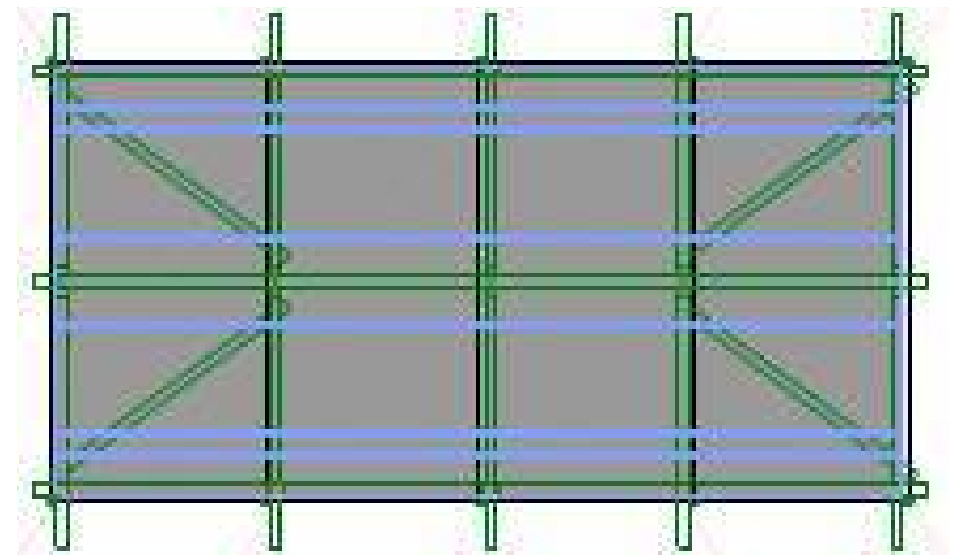

## DESIGN 2

Width of the emergency shelter may vary between 12' to 15' and length may vary between 10' to 16'. Dimension of the shelter may vary to accommodate family size.

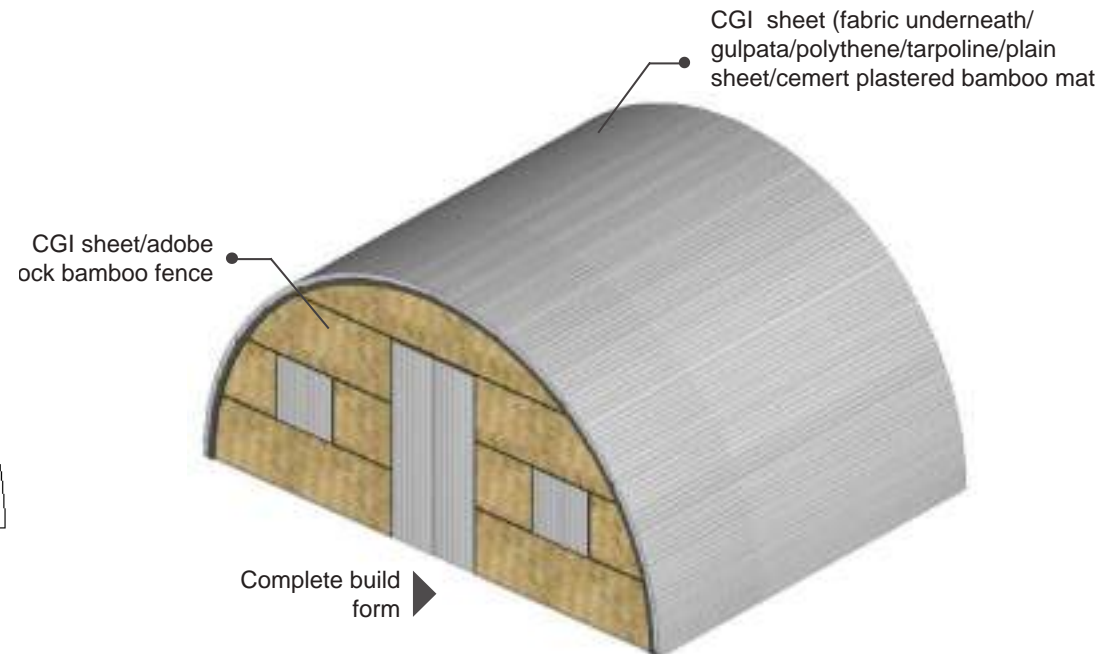
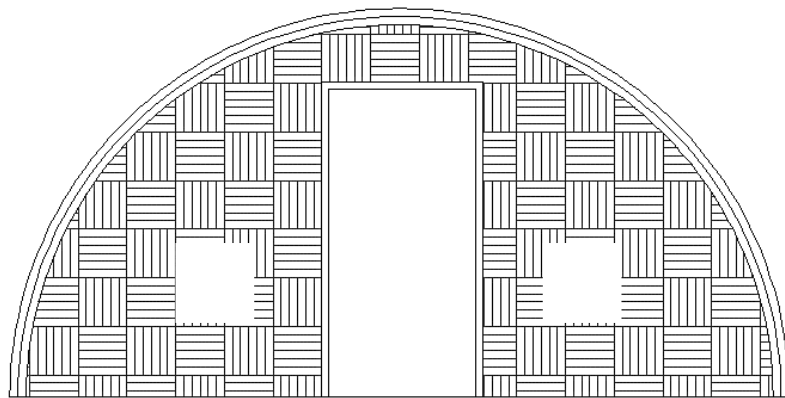
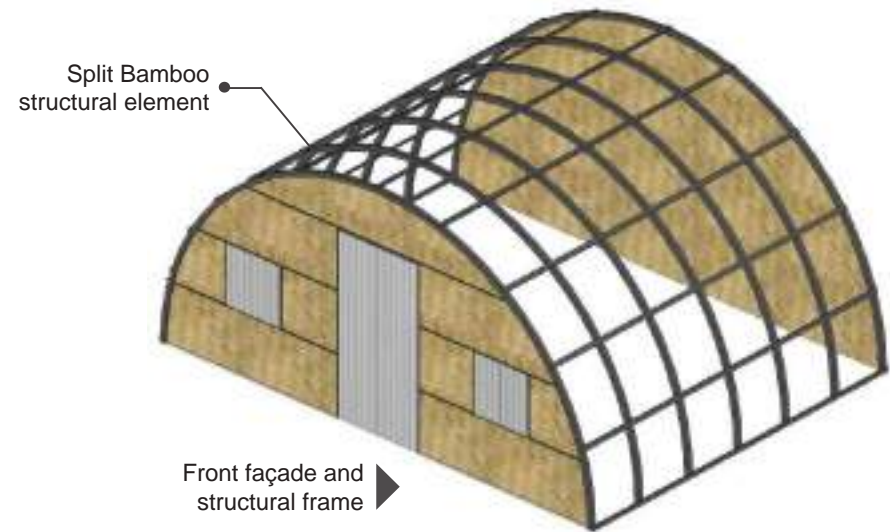

# A BASIC GUIDELINE ON SHELTER UPGRADING

### 3.6 A BASIC GUIDELINE ON SHELTER UPGRADING

A basic Guideline on Shelter Upgrading has been developed by the Shelter Sector in Cox's bazar, Bangladesh in cooperation with Shelter Cluster which is in practice now. Some of these guidelines are presented here:

**Carefully select your plot and location of your shelter** 01

be aware of flooding hazard

be aware of fire hazard

keep a distance in between shelters

**have a strong foundation when building your shelter** 03

**Prepare the plot to receive your shelter** 02

terracing might be needed

raise your shelter to avoid rain water getting inside

1

2

3

raise your shelter using compacted soil

you may also use some sand bags

**reinforce your shelter frame using diagonal bracing** 04

### have strong ties and connections in your shelter 05

diagonal lashing | galvanized tie wire

square lashing | galvanized tie wire

column/beam | galvanized tie wire

### improve the walls and roof of your shelter 07

use bamboo weaving in walls and roof

create partitions for privacy

### create an expansion area for cooking 08

### create drainage around your shelter | connect it to your neighbours and to the main drainage 09

### secure your tarpaulin with ropes and anchor it to the ground 06

secure the tarpaulin and the roof with rope

anchor the shelter roof and tarpaulin using one or several types of anchors suitable for it

fold the end of the tarpaulin

put a stone at the end before the knot

tree stump

peg

sand bag

brick

2 ft

1.5 ft

2 ft

2 ft

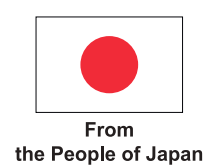





## CHAPTER FOUR

# MINIMUM TECHNICAL STANDARDS FOR SAFER HOUSING

### 4.1 DEFINITION OF SAFER HOUSING

In a context of non-engineered construction, construction expertise is often passed on from generation to generation and from one construction professional to another. Tried and tested over decades, in a particular context, non-engineered housing often holds a lot of inherent wisdom. Construction engineering knowledge on the other hand offers a formal understanding of how particular materials, techniques and designs react under certain circumstances. Moreover, it can offer alternative and innovative ways of addressing current and new challenges for safer construction.

The combinations of tried local practices and engineering knowledge makes allows to formulate standards for safer housing for the different hazards

impacting on the rural housing stock of Bangladesh. Through respecting the general design principles and minimum technical standards for specific threats presented below, the current rural housing stock in Bangladesh can be rendered substantially more resistant to future disasters.

### 4.2 ESTIMATING THREATS IMPACTING ON A HOUSE ON MACRO, MEZZO AND MICRO LEVEL

Determining the hazards that a house is exposed to, and how these hazards pose a threat to the integrity of the house, is the first important step to take in housing and site design. This is to be done on three levels:

**Level 1: Macro- or regional level**

To identify and estimate hazards and threats on the macro-level, the below vulnerability maps can be utilized:

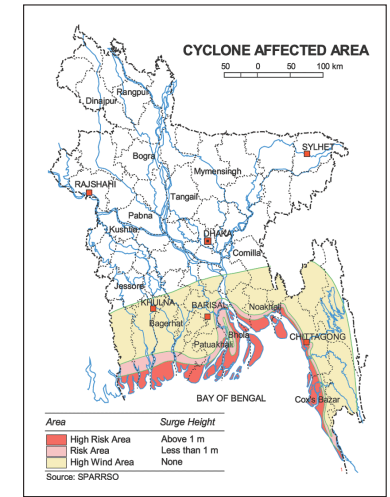
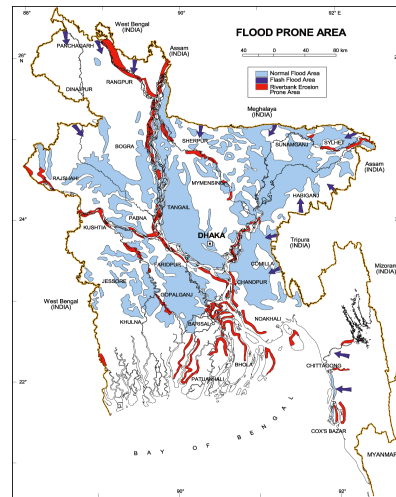

	Cyc I	Cyc II	Cyc III	Coast Eros.	Reg Flood	Flash Flood	River Eros.	Water log.	Land slide	EQ I	EQ II	EQ III
Cyclone I	Light Orange	Light Orange	Light Orange	Light Orange	Light Orange	Light Orange	Light Orange	Light Orange	Light Orange	Light Orange	Light Orange	Light Orange
Cyclone II	Light Orange	Light Orange	Light Orange	Light Orange	Light Orange	Light Orange	Light Orange	Light Orange	Light Orange	Light Orange	Light Orange	Light Orange
Cyclone III	Light Orange	Light Orange	Light Orange	Light Orange	Light Orange	Light Orange	Light Orange	Light Orange	Light Orange	Light Orange	Light Orange	Light Orange
Coastal Erosion	Light Orange	Light Orange	Light Orange	Light Orange	Light Orange	Light Orange	Light Orange	Light Orange	Light Orange	Light Orange	Light Orange	Light Orange
Regular Flood	Light Orange	Light Orange	Light Orange	Light Orange	Light Orange	Light Orange	Light Orange	Light Orange	Light Orange	Light Orange	Light Orange	Light Orange
Flash Flood	Light Orange	Light Orange	Light Orange	Light Orange	Light Orange	Light Orange	Light Orange	Light Orange	Light Orange	Light Orange	Light Orange	Light Orange
River Erosion	Light Orange	Light Orange	Light Orange	Light Orange	Light Orange	Light Orange	Light Orange	Light Orange	Light Orange	Light Orange	Light Orange	Light Orange
Waterlogging	Light Orange	Light Orange	Light Orange	Light Orange	Light Orange	Light Orange	Light Orange	Light Orange	Light Orange	Light Orange	Light Orange	Light Orange
Landslide	Light Orange	Light Orange	Light Orange	Light Orange	Light Orange	Light Orange	Light Orange	Light Orange	Light Orange	Light Orange	Light Orange	Light Orange
EQ I	Light Orange	Light Orange	Light Orange	Light Orange	Light Orange	Light Orange	Light Orange	Light Orange	Light Orange	Light Orange	Light Orange	Light Orange
EQ II	Light Orange	Light Orange	Light Orange	Light Orange	Light Orange	Light Orange	Light Orange	Light Orange	Light Orange	Light Orange	Light Orange	Light Orange
EQ III	Light Orange	Light Orange	Light Orange	Light Orange	Light Orange	Light Orange	Light Orange	Light Orange	Light Orange	Light Orange	Light Orange	Light Orange

Rural areas in Bangladesh are often confronted with a combination of natural hazards. This means that, in most housing designs, measures are to be taken to resist a combination of hazards. The following combinations of hazards are prevalent in Bangladesh:

(Source: Multipurpose Cyclone Shelter Program, 1993)

## Level 2: Mezzo-level or level of larger surrounding

Addressing the larger surroundings of the site: distance to beach/ rivers, particular condition of soil etc., for example: how great is the flash flood risk in this particular area, is the site located on a char etc.? To determine hazards and threats to housing on this level, the above vulnerability mapping is combined with local knowledge and assessment of the actual condition of the site surroundings.

## Level 3: Micro- or plot-level

Addressing the site itself, its edges and immediately surrounding elements, for example: how protective is the vegetation, how stable is the river edge, how high is the highest flood level etc.? To determine hazards and threats to housing on this level, local knowledge and assessment of the actual condition of the site together with the households living there are primordial.

## Weighing threats to housing on macro, mezzo and micro-level

The actual threat posed by hazards to a specific house is to be determined by weighing the threats on macro, mezzo and micro level. This will give a clear indication of the resilience measures that need to be applied to a particular house.

### Examples

Example	macro	mezzo	micro	conclusion
Example house 1	EQ zone I and landslide prone	Sited on top of a hill	House situated on a flat and stable central area of the hilltop	No need to take measures for landslide resistance but EQ resistance measures are to be applied to the house
Example house 2	EQ zone I and landslide prone	Sited on top of a hill	House situated on an unstable edge of the hilltop	Need to move the house away from the edge and/or reinforce the edge of the hill, and EQ resistance measures are to be applied to the house
Example house 3	Cyclone I	Close to the coast line	Very exposed	Risk of storm surge is to be taken into account, stilt housing advised*
Example house 4	Cyclone I	Far from coast line and rivers	Very exposed	Risk of storm surge is not to be taken into account
Example house 5	Cyclone I	Close to the coast line	Homestead raised 3 meters above surrounding areas, plinth 1 meter high, ample protective vegetation available	Risk of storm surge is to be taken into account, but stilt housing is not necessary
Example house 6	Cyclone 'Risk Area'	Within 1 kilometre from a large river	Homestead raised 1.5 meter above surrounding areas, plinth 1 foot high, some protective vegetation	Application of measures for high wind and limited force flash flood is sufficient
Example house 7	Cyclone 'Risk Area' and prone to regular flood	Within 1 kilometre from a large river	Homestead raised 1.5 meter above surrounding areas, plinth 1 foot high, some protective vegetation available	Application of measures for high wind and limited force flash flood are to be combined with measures to protect the house from regular flooding

\* However to avoid the false sense of security of the inhabitants the area to be chosen should not experience tidal surge level more than 7 feet height. The outcome of this weighing assessment defines the resilience measures for safer housing that are to be applied to each individual house and site.

### 4.3 GENERAL DESIGN PRINCIPLES FOR DIFFERENT THREATS



Specific design principles are to be respected to counter the various threats a house may be exposed to. This section is based on a multitude of guidelines that have been produced in the context of previous disaster preparedness and response projects, both in Bangladesh as internationally, by a variety of housing actors.

Since all rural areas in Bangladesh are exposed to a combination of hazards, in most cases, more than just one set of design principles will need to be adhered to. In those cases, the strictest principle across the different hazards is to be applied.

General design principles for strong wind	
1. Break the force of the wind	<p>by means of siting the house behind wind breaking elements such as embankments, dense vegetation etc., or by adding wind breaking elements</p>  <p>(Source: Shelter Coordination Group, Cyclone Sidr, Bangladesh)</p>
2. Reduce the number of elements that can hit the house	<p>ensure all trees close to the house have a vertical root system, ensure that all elements of the house are fixed properly and cannot fly away, reduce the number of other objects that could fly away and hit houses, by storing or fixing them</p>

3. Ensure tie down from bottom to top

the house is to be firmly tied to the ground, to avoid it flying off, starting by connecting the roof well to the columns, the columns well to the foundation and anchoring the foundation well into the ground.

(Source: IFRC BD Shelter Volunteer Training after cyclone Sidr)

4. Ensure cross-bracing in all planes of the house

All planes of the house are to be equipped with cross-bracing to resist the lateral winds impacting on the house, to avoid the house falling over

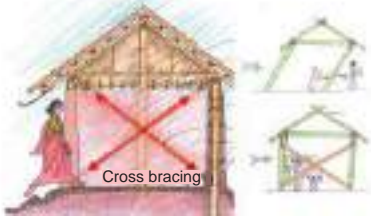

(Source: Handbook on design and construction of rural housing in flood-prone areas in Bangladesh, ADPC, and IFRC BD Shelter Volunteer Training after cyclone Sidr)

5. Ensure that wind pressure cannot build up inside the house

There are two opposite strategies to avoid wind pressure building up inside the house:

- Ensure that wind can flow freely through the house, by ensuring openings on all opposite walls of the house, and by ensuring wind pressure can escape through the roof

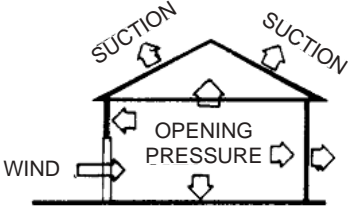

(Source: Make the Right Connections, USAID, OAS, NDFP, SSI)

- Ensure that no wind can enter the house, by closing it off completely, including impermeable walling and latched windows and doors

In most rural housing, certainly when walls are of natural materials, the first strategy is the only possible one.

6. Build in regular volumes

Regular house shapes resist wind impact better. Thereto, structurally split the house into regular shapes. Protect the structural integrity of the main volume by structurally separating secondary volumes from it.

General design principles for regular flood	
1. Raise and protect the homestead	<p>Raise the homestead sufficiently above the surrounding fields, and protect it with vegetation or other slope protection measures</p>  <p>(Source: Handbook on design and construction of rural housing in flood-prone areas in Bangladesh, ADPC)</p>
2. Ensure a qualitative plinth	<p>The house plinth is to be 2 feet above the highest flood level, 2 or 3 stepped and finished with cement capping or other, to resist exposure to water</p>
3. Protect the lower parts of the house	<p>By sufficient roof overhang, proper drainage, treatment of materials, alternative material choices: protect the lower parts of the structure and wall cladding from humidity and exposure to water</p>
4. Apply foundation and bracing	<p>Foundation of sufficient depth is required to resist soil being washed out from underneath the house. Bracing of the superstructure to resist lateral forces from the water and increase the overall stability of the structure.</p>

General design principles for earthquake	
1. Siting on stable soil	<p>Houses should not be constructed on filled ground, both in flat and hilly areas.</p> <p>Houses in hilly areas need to be constructed on a stable slope. Houses are not to be sited downhill from an unstable slope, or this slope is to be stabilized. A safe distance of the stabilized slope is to be maintained, for both of uphill and downhill.</p>  <p>(Source: Construction Manual for Earthquake Resistant houses built of Earth, Gernot Minke, GATE-BASIN, GTZ, 2001)</p>

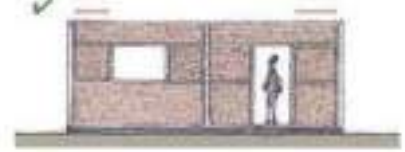
2. Build in regular volumes	<p>Houses in square and rectangular shape (L&lt;3xW) resist earthquakes better than houses in irregular shapes. If the house is built in an irregular shape, a structural split is to be made between the different volumes. This is especially important for houses built in heavy materials.</p>
3. Foundation	<p>Ensure sufficient foundation strength and depth, to keep the house safe in case of liquefaction or sliding of soil</p>
4. Horizontal bracing	 <p>At least at three levels, the bottom ring, at the half height of the wall and at top ring beam level, the house is to be horizontally braced. This is especially important for houses built in heavy materials. Avoid all housing with heavier upper part.</p> <p>(Source: Shelter Safety Handbook, Some Important Information on How to Build Safer, IFRC)</p>
5. Placement of windows and doors	<p>Doors and windows are to be placed so that they do not disrupt the regularity of the structure, and the openings are to be reinforced additionally. This is especially important for houses built in heavy materials.</p>
6. Diagonal bracing	<p>Roof structures are to be diagonally braced in all planes to reduce all irregular movement of the house.</p>

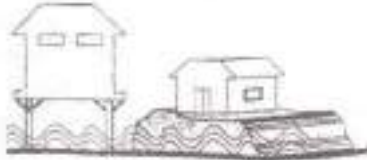

General design principles for flash flood and storm surges	
1. Do not build houses in areas exposed to the full brunt of flash floods or storm surges	<p>The force of flash floods is hard to resist with proper housing design, so the first and foremost general design principle is to not construct housing in areas exposed to the full brunt of flash flood or storm surges.</p> <p>(The high pressure on land however means that many of such unsuitable areas continue to be inhabited, so please find general design principles below).</p>
2. Break the force of the water	<p>Measures can be taken to break the force of the water: reinforcing embankments and river edges, siting houses on raised homesteads or stilts, and providing protective vegetation</p>  <p>(Source: Guidelines for Cyclone Resistant Construction of Buildings in Gujarat, GSDMA, GoG, 2001)</p>
3. Withstand the force of the waves	<p>There are two opposing strategies that can be adopted:</p> <ul style="list-style-type: none"> <li>The house structure doesn't obstruct the free passage of waves and objects caught up in the waves. Thereto, if necessary, bracing at the bottom of the structure can be included inside the plinth along with the bracings at other strategic point above. Stilt house is such an example.</li> <li>The house structure is reinforced, braced horizontally and diagonally, and with heavy materials at the lower parts, so that it functions as a solid block that can resist the force of the waves.</li> </ul>
	<p>The first strategy is preferred for houses that suffer the brunt of the flash flood and storm surge, while the second is preferred for houses located a bit further away from the immediate impact.</p>

General design principles for coast and river erosion	
1. Build houses that can be moved	<p>The forces of coast and river erosion can't be resisted with proper housing design, so the general design principle is to not construct durable housing in areas prone to coast or river erosion.</p> <p>(The high pressure on land however means that many of such unsuitable areas continue to be inhabited).</p> <p>Housing is to be built that can be dismantled and re-erected elsewhere.</p>
2. Ensure structural stability in moveable housing	<p>Techniques and tricks are to be applied to ensure structurally safe housing in moveable parts. Connections are crucial in this: these should not loose structural strength by dismantling and re-assembling multiple times</p>

General design principles for landslides	
1. Reduce risk of landslides	<p>The risk of landslides occuring can be reduced by protecting and increasing the vegetation that holds the earth, and the slope, together and stable.</p>
2. Do not locate houses on sites that are at risk of landslides	<p>The force of a landslide is difficult to resist by proper house design. Sites that are at risk of landslides are unsuitable for construction.</p> <p>(The high pressure on land however means that many of such unsuitable areas continue to be inhabited, so please find general design principles below). Same as for earthquake prone areas, housing is to be sited away from unstable slopes, both uphill as downhill.</p>

3. Retaining walls or construction on stilts	<p>There are two options for constructing safely on slopes:</p> <ul style="list-style-type: none"> <li>Option one is to build on stilts. This is only advised on stable slopes, and if sufficiently deep foundations can be foreseen into stable ground</li> <li>Option two is to make a flat terrain protected both up- and downhill by retaining walls. Also in this option, a strong foundation is crucial, as in any housing</li> </ul>  <p>(Source: Shelter Safety Handbook, Some Important Information on How to Build Safer, IFRC)</p>
--	--

#### 4.4 MINIMUM TECHNICAL STANDARDS FOR HIGH WIND, FLOOD AND EARTHQUAKE PRONE AREAS

The forces presented by flash floods, storm surges, coastal and river erosion and landslides cannot be countered by appropriate house design alone. Sites exposed to such hazards are considered unsuitable for construction, unless extensive landscaping is done. In this section, minimum technical standards are therefore limited to housing exposed to high wind, regular floods and earthquakes. However, throughout these standards, some measures against / references to flash floods, storm surges, erosion and landslides are included, for as much as this is possible.

This section is largely based on the recommendations formulated throughout the workshops leading up to the development of these Guidelines, and the many previous work completed in this area by in-country housing actors.

**Standards for Cyclone 'High Risk Area' and 'Risk Area'**\*

**Standard for homestead organisation**

- Homesteads are raised at least 5' above the level of the surrounding fields/ ponds
- The edges of the homesteads are to be protected with dense vegetation of different heights and with different root systems. Earth bag reinforcement or reinforcement with natural netting may be added.
- Trees with horizontal root systems are to be planted at sufficient distance from the house
- Closer to the house, only trees with vertical root systems are advised
- Rainwater collection and drainage: half 6" diameter PVC pipe gutters to be installed along the roof edges, fixed with 1.5" metal U/V shape clamps. Collecting of rain water in a PVC receptor or discharge in a drainage path leading away from the house
- If a homestead is lacking, and can't be built, and the site is extremely exposed to the force of cyclone winds and storm surges, housing on RCC stilts is advised. However to avoid the false sense of security of the inhabitants, the area to be chosen should not experience tidal surge level more than 7 ft height.

\* See the map for cyclone affected area to obtain the extend of 'High Risk Area' and 'Risk Area'.

**Standard for plinth**

- Plinth height is to be minimum 2 feet above the homestead level. If the homestead level is less than 5 feet above the surrounding fields/ ponds, and can't be heightened, the plinth height is to be minimum 3 feet above the homestead level.
- The plinth is of stabilized soil with a minimum of 5% cement content (depending on affordability and type of soil), or with Ferro cement finishing, or protected with compressed mud blocks or eco-friendly bricks walls with cement mortar 1:4
- The plinth of the toilet is to follow the same design

**Standard for foundation**

- Foundations have a minimum depth of 2 feet into the Finished Ground Level
- Only RCC/Ferro Cement foundations are allowed, for both the main volume of the house as for any additional structures such as the veranda
- Foundation poles have a T-footing (foot is 5" by 5" by 17") with a compacted backfilling
- OR foundation poles, with 2 reinforcement bars sticking through the pole at 5" height from the bottom, are sunk in a 3' feet deep hole minimum 15" by 15" backfilled with concrete 1:2:4
- OR foundation poles are cast in-situ with a 1' 6" concrete 1:2:4 base
- OR foundation poles are drilled into undisturbed earth and interconnected by masonry work (no less than 15" height) up to plinth height that is reinforced in connection to the foundation poles at two levels; working as a ring beam. Masonry wall with cement mortar 1:4

**Standard for superstructure**

- Columns are to be placed at a maximum following distances from centre to centre :
  - i. For RCC/Ferro Cement column dimension 5" by 5", maximum centre to centre distance 5'-6"
  - ii. For RCC/Ferro Cement column dimension 6" by 6", maximum centre to centre distance 6'-0"
  - iii. For RCC/Ferro Cement column dimension 7" by 7", maximum centre to centre distance 7'-6"
- RCC/Ferro cement column size is at least 5" by 5" and has pre-defined holes or connection points to connect wall cladding and house extensions to
- Wooden column size is at least 3" by 5"
- Connection of wooden columns onto RCC/Ferro Cement foundation is done using a pre-cast metal clamp and double bolting
- Veranda is to be structurally split from the main volume of the house
- Windows and doors need to be connected, with joints and connections as described below, to the secondary structure of the house supporting the wall cladding

**Standard for roof structure**

- A hipped shaped roof is standard for all three cyclone zones
- Gable shaped roof should not be allowed for cyclone 'High Risk Area' shown in the cyclone affected area map unless or until adequate safety structural measures are ensured and only if the house is sufficiently protected from exposure: by being situated on a large homestead with dense vegetation, at least 2 kilometres removed from large rivers or the coastline
- The slope of the roof should be approximately 30°
- The length of the canopy is to be limited to 1' 6"
- The roof structure is to be a truss system, a traditional roof structure or a Ferro cement structure or any other innovative method of roofing that assures equivalent safety parameters or more.
- Appropriate sections of all elements of the roof structure are to be applied, in coherence with the structural design and material choice of the roof structure. Roofing material like tin sheet often causes for unwanted casualties on face of cyclonic impacts, and should be avoided. If it is used, measures are to be taken to fix the tin sheets properly.

**Standard for bracing**

- Cross-bracing is to be provided in all planes of the house: in the walls, in all planes of the roof structure and in the roof plane, with appropriate material sections and appropriate joints
- Tie down from top to bottom is to be ensured, with the tie down quality gradually increasing from top to bottom

**Standard for joints**

- Nuts and Bolts, reinforcement with metal plates, metal straps or folded metal rebar is to be applied in all primary connections of the structure of the house, coated or painted, such as purlin to rafter, rafter to beam connections, beam to columns, truss member connections etc.
- For wood connections, lap joints are preferred.
- Double nailing is allowed only for secondary elements of the house such as connections in the wall cladding
- Single nailing in cyclone prone area is not allowed in any part of the house.
- Any corrugated roofing element are to be fixed to the roof structure using steel capped screws and rubber washer, at the high curve of the corrugation, every third corrugation, and every single corrugation near all edges. Same for ridge cover.
- Steel connections are to be pre-welded in a controlled environment, or with nut and bolt connections. In situ welding is not allowed.
- Wall cladding is to be fixed properly upon the structure, with special attention to the edges

**Standard for materials**

- All wood is to be seasoned and treated hard wood
  - All RCC elements should come at least with 4 profiled reinforcement MS bars of 8 mm, 40 grad, and 6mm MS stirrups every 5". The clear cover of the MS bar should be at least 1.25' for precast concrete, and 2' for cast in-situ.
  - All concrete is mixed not less than 1:1½ :3, with clean water (free from salt and organic particles), fine aggregate of clean river sand (free from salt and organic particles), and coarse aggregate of ½" downgraded gravels or crushed bricks, using Ordinary Portland Cement, slump for wet concrete; 1.5"
  - Lower parts of walls are to be treated to resist humidity and attack by rodents and insects
  - Bamboo is to be treated by natural or chemical leaching and tarring when in contact with the ground
  - Steel frames are to be coated with metallic anti-corrosive paints.
  - Ferro cement: the net spacing, the material used for the netting, the minimum cement coverage and cement mixture are to follow BNBC
  - Bricks like masonry modules/units are to be produced in eco-friendly facilities, with reduced fuel use and air pollution and the corresponding masonry work is to follow BNBC
  - Compressed mud blocks have the appropriate cement-soil ratio and are compressed with the appropriate strength, and fully dry
  - Tin sheets as a walling material need to be of minimum 0.36mm Gauge thickness and galvanized
  - Plastering is to be 12mm with saline protective chemical solutions (ratio: 250 ml per cement bag)

**Alternative techniques**

Alternative techniques are allowed for as much as they obtain the same structural integrity as the above advised techniques

**Standards for areas prone to regular flooding**

**Standard for homestead organisation**

- Homesteads are raised at least 5' above the level of the surrounding fields/ ponds
- The edges of the homesteads are to be protected with dense vegetation of different heights and with different root systems. Additionally, earth bag reinforcement, or reinforcement with natural netting is to be added.
- A system of drainage paths is to be organized to evacuate water from the homestead, away from the houses, to the surrounding not inhabited areas
- Rainwater collection and drainage: half 6" diameter PVC pipe gutters to be installed along the roof edges, fixed with 1.5" metal U/V shape clamps. Collecting of rain water in a PVC receptor or discharge in a drainage path leading away from the house
- For housing exposed to the brunt of flash floods, construction on stilts is advised For sites prone to river erosion, movable housing is advised
- For construction on chars, raised collective homesteads are advised
- For housing in permanently waterlogged areas, floating housing can be considered

**Standard for plinth**

- The plinth is to be at least 2' above the Highest Flood Level known in the area
- The plinth is to be stepped, 2, 3 or more steps, stabilized soil with a minimum of 5% cement content (depending of affordability and soil type), or with Ferro cement finishing, or protected with compressed mud blocks or eco-friendly bricks walls with cement mortar 1:4
- The plinth of the toilet is to follow the same design

**Standard for foundation**

- Foundations have a minimum depth of 2' into the Finished Ground Level
- Only appropriate RCC/Ferro Cement foundation or any masonry module foundation with due strength are allowed
- Other types of foundation can be used for additional volumes to the house such as kitchen or veranda, if measures are taken for protection against water or for easy replacement
- Few forms of foundation methods are as follow:
  - i. RCC/Ferro Cement foundation poles are sunk in a 2' feet deep hole minimum 15" by 15" backfilled with concrete 1:2:4

- ii. Or foundation poles are cast in-situ with a 1' 6" concrete 1:2:4 base
- iii. Or RCC/Ferro Cement foundation blocks are used, minimally 8"by 8" by 4', 1:2:4 mixture, upon which the superstructure is mounted using metal clamps
- Any strong masonry unit/module made foundation of 2/3 steps with cement mortar 1:4

**Standard for cladding**

- All lower parts of the wall cladding are to be separately replaceable, or of a different material / improved protection that is more resistant to standing
- All wall cladding is to be kept off from the ground, by placing, on the plinth, a layer of eco-friendly produced bricks, compressed mud blocks or an equally performing technique
- Attention is to be given to all wall cladding connections to reduce infiltration of rain water and exposure of materials to water, especially the structural elements of the house; examples are capping of nail holes, folding of bamboo slates over connections etc.

**Standard for superstructure**

- All lower parts of the superstructure are to be protected from humidity, water, rodents and insects by proper treatment, material choice and techniques
- Columns are to be placed at a maximum following distances from centre to centre :
  - i. For RCC/Ferro Cement column dimension 5" by 5", maximum centre to centre distance 5'-6"
  - ii. For RCC/Ferro Cement column dimension 6" by 6", maximum centre to centre distance 6'-0"
  - iii. For RCC/Ferro Cement column dimension 7" by 7", maximum centre to centre distance 7'-6"
- RCC/Ferro Cement column size is at least 5" by 5" and has pre-defined holes or connection points to connect wall cladding and house extensions to
- Wooden column size is at least 3" by 5"
- Bamboo column diameter is at least 4"
- Mud walls are to be properly compressed and a structurally acceptable width and design is to be determined for mud walls with or without reinforcement, taking into account the soil type
- Connection of wooden or bamboo columns onto RCC/Ferro Cement foundation is done using a pre-cast metal clamp and double bolting
- Windows and doors need to be connected to the secondary structure of the house supporting the wall cladding

<p><b>Standard for roof structure</b></p> <ul style="list-style-type: none"> <li>- The roof shape can be hipped or gable or mono pitched (if proper strength assured)</li> <li>- The canopy has to have a sufficient overhang to protect the plinth and the lower parts of the wall from rainfall. The areas where rainwater run-off from the roof could fall are to be protected additionally.</li> </ul> <p>Appropriate sections of all elements of the roof structure are to be applied, in coherence with the structural design and material choice of the roof structure</p>
<p><b>Standard for bracing</b></p> <ul style="list-style-type: none"> <li>- Corner-bracing is to be provided to all structurally important connections of the house</li> <li>- Tie down principles are to be respected throughout the house: proper fixing of internal roof structure, of roof to columns, from columns to foundations, and of foundation into the ground</li> </ul>
<p><b>Standard for joints</b></p> <ul style="list-style-type: none"> <li>- For wood connections, lap joints are preferred</li> <li>- Double nailing is to be applied to all structural elements of the house, important connections are to be reinforced with mild steel bands</li> <li>- Tin sheets are to be fixed to the roof structure using steel capped screws and rubber washers</li> <li>- The joints of corner bracings in particular require attention; advised is to reinforce these connections with metal plates</li> <li>- All ties with rope or wire are to be done up to the best local standard</li> <li>- Steel connections are to be pre-welded in a controlled environment, or with nut and bolt connections. In situ welding is not allowed.</li> <li>- Wall cladding is to be fixed properly upon the structure, with special attention to the edges</li> </ul>
<p><b>Standard for materials</b> Same as for cyclone zones</p>
<p><b>Alternative techniques</b></p> <p>Alternative techniques are allowed for as much as they obtain the same structural integrity as the above advised techniques.</p>

<p>Standard for earthquake 'High Risk Area' and 'Risk Area'</p>
<p><b>Standard for siting</b></p> <ul style="list-style-type: none"> <li>- Houses are to be built on stable soil, not on filled ground</li> <li>- Slopes that a house is built on are to be stable, or rendered stable</li> <li>- Houses are to be sited at a sufficient distance from slopes, both up- and downhill, and from any other structures in the vicinity that may be unstable</li> <li>- OR houses are built on stilts sufficiently deep into stable soil</li> </ul>
<p><b>Standard for plinth</b></p> <ul style="list-style-type: none"> <li>- The plinth is to be stabilized with a minimum of 5% cement content (depending on affordability and type of soil), or with Ferro cement finishing, or protected with compressed mud blocks or eco-friendly bricks walls with cement mortar 1:4</li> <li>- The plinth of the toilet is to follow the same design</li> </ul>
<p><b>Standard for foundation</b> Same as for regular flooding</p>
<p><b>Standard for bracing</b></p> <ul style="list-style-type: none"> <li>- The entire house structure is to be horizontally braced, at least at three levels: a bottom ring beam, a middle-height wall ring beam and a top ring beam: these beam are to be reinforced and properly anchored to the vertical structure of the house</li> <li>- Diagonal and/or corner bracings are to be additionally added to all planes of the roof structure</li> <li>- Window and door openings need to be anchored into the structure of the house</li> <li>- Tie down principles are to be respected throughout the house: proper fixing of internal roof structure, of roof to columns, from columns to foundations, and of foundation into the ground</li> <li>- The above are particularly important for heavy structures</li> </ul>
<p><b>Standard for superstructure</b> Same as for regular flooding</p>
<p><b>Standard for roof structure</b> Same as for regular flooding</p>
<p><b>Standard for joints</b> Same as for regular flooding</p>
<p><b>Standard for materials</b> Same as for cyclone zones</p>
<p><b>Alternative techniques</b></p> <p>Alternative techniques are allowed for as much as they obtain the same structural integrity as the above advised techniques.</p>



## 4.5 DESIGN EXAMPLES FOR SAFER HOUSING

The following examples of house designs have been developed by a variety of housing actors in Bangladesh, and have been implemented in the field. If minor changes and a final review against the standards is made, these designs can be made to comply to the minimum technical standards as set out in these Guidelines.

Together with the many other designs that are available in the country with various housing actors and are not included in these Guidelines, they can form an inspiration for housing actors planning housing projects.

### DESIGN 1

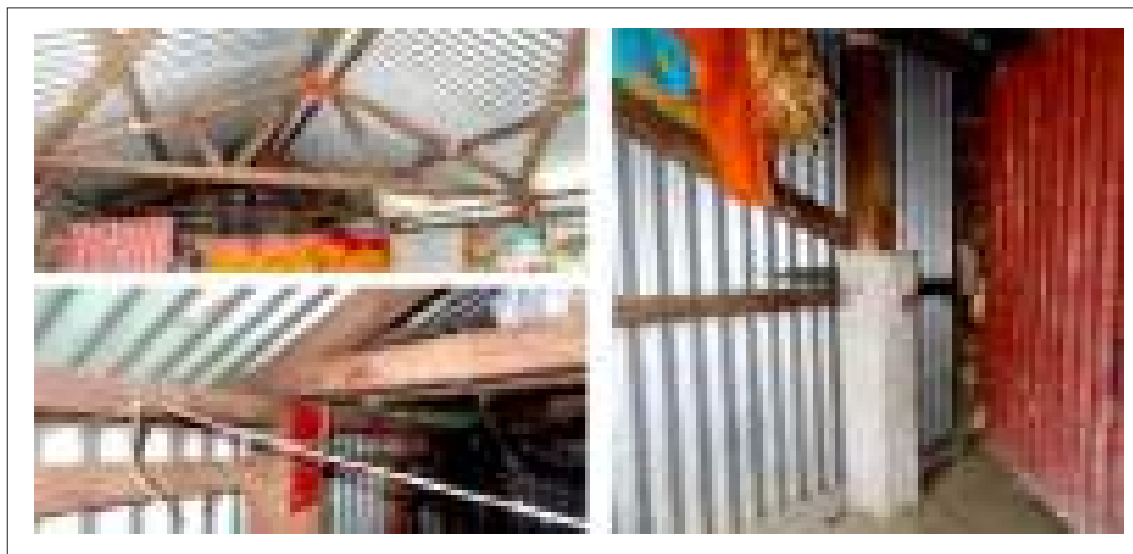

Structure	RC stump foundation with cast-in metal clamp on which a wooden superstructure is mounted. The wooden joints are reinforced with metal plates. and the structure is braced in all directions.  Fully coherent with minimum standards
Cladding	The wall is of alternative blocks or painted CGI sheets. Roots in CGI sheets.  Coherent with minimum standards provided that the wall is of alternative blocks or painted CGI sheets, 3 windows materials
Space plan	Approx 11 by 18 feet internal space. One internal space, 3 windows. 1 door  Fully coherent with minimum standards
Area of application	Applicable for all areas in case of coastal areas, use of CGI sheet should be avoided.

Originally developed by the British Red Cross and Bangladesh Red Crescent.

**Safe site selection and preparation** are crucial in case there is a risk of coastal erosion, flash flooding, river erosion and landslide.

#### Treatment needs

- Painting of wood against rot and insect infestation
- Painting or galvanization of metal plates

#### Alternatives

The concrete stump foundation is a good alternative to the full length concrete column; for transport to areas that are difficult to reach.

## DESIGN 2



Structure	RC columns and foundation, wooden roof structure, hipped. Fully cross and horizontally braced and bolted. <b>Fully coherent with minimum standards</b>
Cladding	Bamboo fencing and CGI roof cladding. <b>Coherent with minimum standards provided that</b> the lower part of the bamboo fencing is protected.
Space plan	10 by 15 feet internal space. One internal space, 1 door, 2 windows. <b>Coherent with minimum standards provided that</b> it is rendered bigger, or a veranda is added. In that case, it is advised to add 2 more windows.
Area of application	Applicable for all areas in case of coastal areas, use of CGI sheet should be avoided.

Originally developed by Islamic Relief based on a design by UNDP

**Safe site selection and preparation** are crucial in case there is a risk of coastal erosion, flash flooding, river erosion and landslide

### Treatment needs

- The wooden roof structure is to be painted to protect from rot

### Alternatives

- The lower part of the wall can be replaced with painted tin sheets, eco bricks or other.

## DESIGN 3



Structure	RC foundation footing and columns combined with bamboo poles in concrete footing. Wooden roof structure, hipped. Corner bracing throughout the structure. Double step plinth. <b>Fully coherent with minimum standards provided that</b> the plinths is reinforced and the corner bracing is executed well.
Cladding	Cladding: Lower part wall in protected CGI on top of a protective layer (CSEB, sand cement block etc. Upper part wall in bamboo matting. Roof in CGI. <b>Fully coherent with minimum standards</b>
Space plan	Approximately 18 by 10 feet internal space, two rooms, internal machan, ceiling, veranda, 1 door, 4 windows. <b>Fully coherent with minimum standards</b>
Area of application	Applicable for all areas in case of coastal areas. Use of CGI sheet should be avoided.

Originally developed by Caritas Bangladesh in collaboration with Bangladesh University of Engineering and Technology (BUET) and CRAterre.

**Safe site selection and preparation** are crucial in case there is a risk of coastal erosion, flash flooding, river erosion and landslide

### Treatment needs

- MS angle treated against corrosion
- Treatment of natural wall cladding

## DESIGN 4



Structure	RC foundation footing and columns. Welded MS angle roof structure bolted onto columns. Indication for bracing, but not detailed. Gable roof.
	<b>Coherent with minimum standards provided that</b> plinth to be reinforced, bracing to be detailed.  Furthermore coherent with minimum standards
Cladding	Natural matting, woven in two directions. Roof and side roof traingle in CGI sheets.
	<b>Coherent with minimum standards provided that</b> the lower wall part is protected with painting or by adding some layers of eco-brick or CGI sheet.
Space plan	18 by 10 feet internal space, 5 by 10 feet veranda. Two internal spaces, 4 windows, 1 door
	<b>Fully coherent with minimum standards</b>
Area of application	Applicable for all areas in case of coastal areas, use of CGI sheet should be avoided.

Originally developed by Care Bangladesh

**Safe site selection and preparation** are crucial in case there is a risk of coastal erosion, flash flooding, river erosion and landslide

### Treatment needs

- MS angle treated against corrosion
- Treatment of natural wall cladding

## DESIGN 5



Structure	RC foundation and column structure braced with steel cables. Roof structure in welded trusses of MS angle bolted onto columns. Gable roof.
	<b>Fully coherent with minimum standards</b>
Cladding	Bamboo matting
	<b>Coherent with minimum standards provided that</b> the lower part of the bamboo matting is well-protected or replaced a more durable material
Space plan	Approximately 10 by 12 feet internal space. One internal space, 1 door, no windows.
	<b>F coherent with minimum standards provided that</b> the internal space is enlarged or a large veranda is added, and windows are added <b>fully coherent with minimum standards</b>
Area of application	Applicable for all areas in case of coastal areas, use of CGI sheet should be avoided.

Originally developed by Bangladesh Red Crescent Society

**Safe site selection and preparation** are crucial in case there is a risk of coastal erosion, flash flooding, river erosion and landslide

### Treatment needs

- MS angle treated against corrosion
- Treatment of natural wall cladding

**DESIGN 6**

Structure	RC foundation bound by 5 layer bricks, RC columns, cross-braced. Roof structure in welded and bolted MS angle. Hipped roof.
	<b>Fully coherent with minimum standards</b>
Cladding	5 layer brick wall with bamboo mats
	<b>Coherent with minimum standards provided that</b> the lower part of the wall is protected from humidity: treatment of bamboo/and or use of a more resistant material
Space plan	10 by 15 feet internal space. One internal space 3 windows, 1 door. Designed to have an internal ceiling and to build a veranda against
	<b>Coherent with minimum standards provided that</b> the space is enlarged, or a veranda is added onto it.
Area of application	Applicable for all areas in case of coastal areas, use of CGI sheet should be avoided.

Originally developed by the International Federation of Red Cross and Red Crescent Societies and the Bangladesh Red Crescent Society

**Treatment needs**

- MS angle treated against corrosion
- Treatment of natural wall cladding

**Alternatives**

This is a very technical design and can be primarily architecturally improved

**DESIGN 7**

Structure	RC foundation stumps with metal clamp onto which a wooden structure is bolted.
	Superstructure and floor in wooden timber and poles. Corner bracing throughout.
	<b>Fully coherent with minimum standards</b>
Cladding	Lower part wall in treated bamboo mats, upper part in regular bamboo mats. Roof in CGI
	<b>Fully coherent with minimum standards</b>
Space plan	Approximately 18 by 10 feet internal space, two rooms, 1 door, 3 windows.
	<b>Fully coherent with minimum standards</b>
Area of application	Applicable for all areas in case of coastal areas, use of CGI sheet should be avoided.

Originally developed by Caritas Bangladesh in collaboration with Bangladesh University of Engineering and Technology (BUET) and CRAterre.

**Safe site selection and preparation** are crucial in case there is a risk of coastal erosion, flash flooding, river erosion and landslide

**Important note!**

This design is especially developed for groups living in the hill tracts, as their cultural practice is to live in raised houses.

**Alternatives**

The roof structure can also be made out of wood elements combined with bamboo elements, or entirely out of bamboo; The roof cladding can be done in thatch.

**Treatment needs**

- Wood and bamboo to be treated against rot and insect infestation

## DESIGN 8



Originally developed by Caritas Bangladesh in collaboration with Bangladesh University of Engineering and Technology (BUET) and CRAterre.

**Safe site selection and preparation** are crucial in case there is a risk of coastal erosion, flash flooding, river erosion and landslide

### Alternatives

- This walling system is inspirational for use in other designs

### Treatment needs

- Wood and bamboo to be treated against rot and insect infestation

Structure	Lower part mud wall with an internal bamboo structure, upper part plastered bamboo matt. Bamboo poles in concrete footing. Triple plinth. Roof structure in wood with bamboo. Corner bracing throughout.
	Coherent with minimum standards provided that the corner bracing is executed well.
Cladding	Lower part wall in mud, upper in plastered bamboo matt.
	<b>Fully coherent with minimum standards</b>
Space plan	Approximately 18 by 10 feet internal space, two rooms, large overhang. 1 door, 4 windows. Ventilation grate underneath roof.
	<b>Fully coherent with minimum standards</b>
Area of application	Applicable for all areas in case of coastal areas, use of CGI sheet should be avoided.



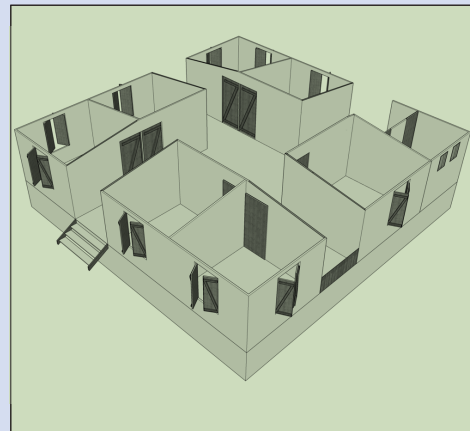
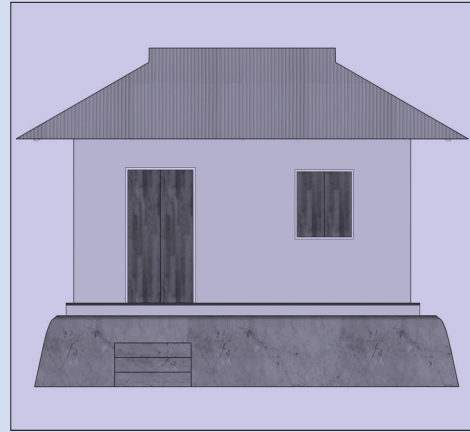
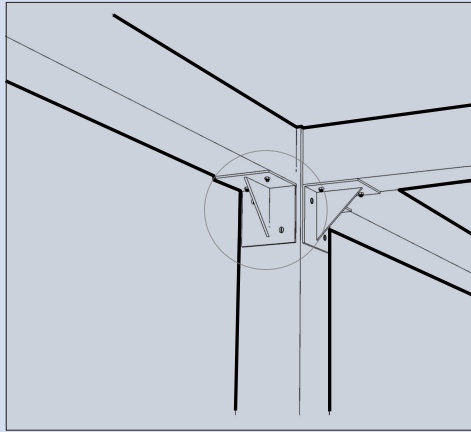

PART THREE

# DURABLE HOUSE DESIGN



## CHAPTER ONE

# DESIGN ASPECTS

### 1.1 BASIS FOR FOCUS AREA OF DESIGN

Bangladesh is prone to different natural and climatic impacts due to its diverse geographic features. A certain geographic area faces multiple natural impacts. While designing a housing module for a specific area, considering only one impact may not be an appropriate approach for resilient design standard. Therefore, this design catalogue is prepared based on four broader geographic regions of Bangladesh; considering the predominant natural extremities that occur in the respective areas and can be considered as the determinant force for shaping the mode of habitation. Hence the profile of such dominant impacts has been considered as the keystone basis for house designs as well as for addressing other occurring impacts within the same region. The four focal areas that are considered :

- ▶ Coastal Area
- ▶ Flood plain/ Char Area
- ▶ Haor Area
- ▶ Hilly Area

### 1.2 BASIS FOR FOCUS ENTITY OF DESIGN

Housing is a more complex commodity than most people realize. It represents a comprehensive scenario considering the social, economic, environmental and many other aspects of a society. The term “Housing” might be implying the design sphere of more macro level, covering the entire settlement or a homestead or any other mode of cumulative living conditions. Whereas this design catalogue focuses on the representation of various design schemes for individual house modules targeted for specific natural impacts at specific regions. These different house modules like Durable and Transitional houses can be adapted to form diverse housing clusters respecting the local settlement patterns of those areas. Therefore, single module of houses has been taken as focus entity of design rather than considering the concept of housing as a whole.

## CHAPTER TWO

# DESIGN FOR COASTAL AREAS

### 2.1 GEOGRAPHIC PROFILE

Cyclones and tidal surges are of unique geographic allocation, considered the most regular catastrophic phenomena along the coastal regions of Bangladesh. An average frequency of sixteen such disturbances occur annually, particularly with concentration in two periods: April-May and October-December. Customarily the southern part of the country, adjacent to the Bay of Bengal including the coastal districts of Chittagong, Bhola, Barguna, Pirojpur, Noakhali, Patuakhali, Satkhira and Laxmipur; portrays the devastating features of cyclonic occurrences. The country is one of the worst sufferers of such casualties in the world. Cyclone has affected around 20 million poverty-stricken people in 15 districts and hundreds of offshore islands. Till today, 45 major cyclones have been recorded of which some catastrophic cyclones are of 1965, 1970, 1985, 1991, 1997, 2007, 2009 and 2013.

in the number of affected population and resources along the coastal belt of Bangladesh. The generic and case specific climatic features are:

- ▶ Cyclone
- ▶ Tidal Surge
- ▶ Nor westerly
- ▶ Solar Radiation etc.
- ▶ High wind pressure
- ▶ Driving Rain
- ▶ Salinity

### 2.3 HAZARD PROFILE

Cyclones generate numerous impacts on individuals life and livelihood. They destroy crops, damage infrastructures, homes and vital installations, and cause widespread health hazards for the people. Storm surges create both short and long-term problems, as salt water degrades the soils. They occur frequently and in such magnitude in Bangladesh that they have multiplied the problem

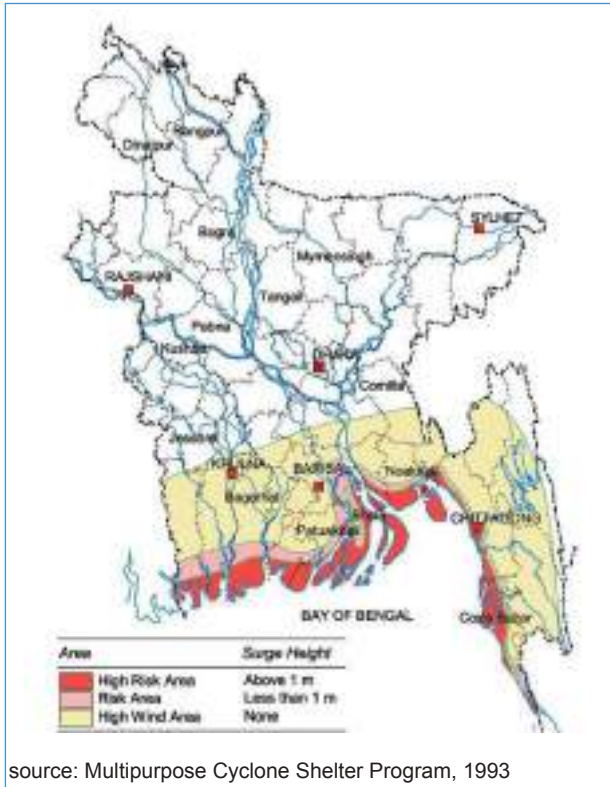

source: Multipurpose Cyclone Shelter Program, 1993

### 2.2 CLIMATIC FACTORS FOR DESIGN CONSIDERATION

Unique geographical location and funnel shaped coastline are the major causes to intensify the cyclone propagation and height of the storm surges in the southern districts. High population density and very flat topography are the main causes of increase





of poverty and seriously challenged the efforts of the country towards self-reliance. Occasionally, tropical cyclones also cause enormous numbers of casualties. The cyclone disasters in 1970( 300,000 dead) and 1991 (138,000 dead) are among the worst natural disasters in the world. In Bangladesh nearly 4,641,060 people are exposed in areas under the threat of cyclones. Lack of impact resilient and engineered housing augment the severity of the damages. Only the cyclone SIDR (November, 2007) damaged 1,522,077 houses of which over 564,967 were fully destroyed and 957,110 were partially destroyed.

## 2.4 PREVAILING PRACTICES

### Local Practices

- ▶ RCC post and metal/wooden frames are dominant in structure.
- ▶ CGI/plain metal sheets are used as wall and roofing material.
- ▶ Timber used as door and window frames.
- ▶ Both pucca and semi-pucca plinths are found in structure.
- ▶ Bamboo mats/ tarpaulins are used under roofs in order to mitigate the heating.
- ▶ An additional semi-outdoor space known as “Pashchati” surrounds the main core house and helps in accommodating various service oriented functional households requirements.

### Introduced Housing by Different GOs and NGOs

- ▶ Use of RCC posts and metal frames are common.
- ▶ CGI sheet as wall and roofing material is dominant in structure.
- ▶ Stilt housing is found in some areas.
- ▶ In certain houses, galvanized, colored CGI sheets are used as roofing and wall material.
- ▶ Rain water harvesting has been introduced in the houses of Rakhain community.

### Community Feedback

- ▶ Houses should be near work places as many previous examples were found unsuccessful.
- ▶ Houses should be in the inner areas of the dam/embankments.
- ▶ Minimum plinth height 2’( height might vary in case of low lying areas and flood level, base should be properly prepared)
- ▶ Plinth should be fully stabilized/pucca.
- ▶ Cross bracing of appropriate materials needs to be used.
- ▶ In case of precast elements, transportation is an issue

### Issues Identified

- ▶ Salinity of water necessitates for pre-fabricated building elements.
- ▶ Pashchati, as an addition around the main house could be added to ensure safety and daily life household functionality.

- ▶ Durable structural members concerning issue of longer house life span.
- ▶ Structural members to be fastened to each other properly.
- ▶ Additional structural stability to be ensured by the means of introducing bracing elements at various points.



Existing local practices in coastal regions



Chungapasha Government housing

Housing by AVAS, Speed Trust & Action Aid



Nachnapara housing (Lions club)

Houses by Friendship



Caritas housing

Rakhain community houses

## 2.5 DESIGN CONSIDERATIONS

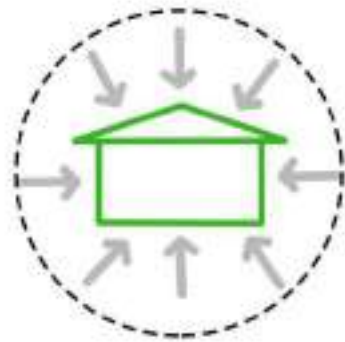

Resilience against the impacts



Introduction of low impact building material and construction technology



Development of standardized and labor friendly pre-fabricated mode of construction using minimum/economic building elements



Addressing contextual issues



Climate responsive design approach

## 2.6 BUILDING TYPOLOGY

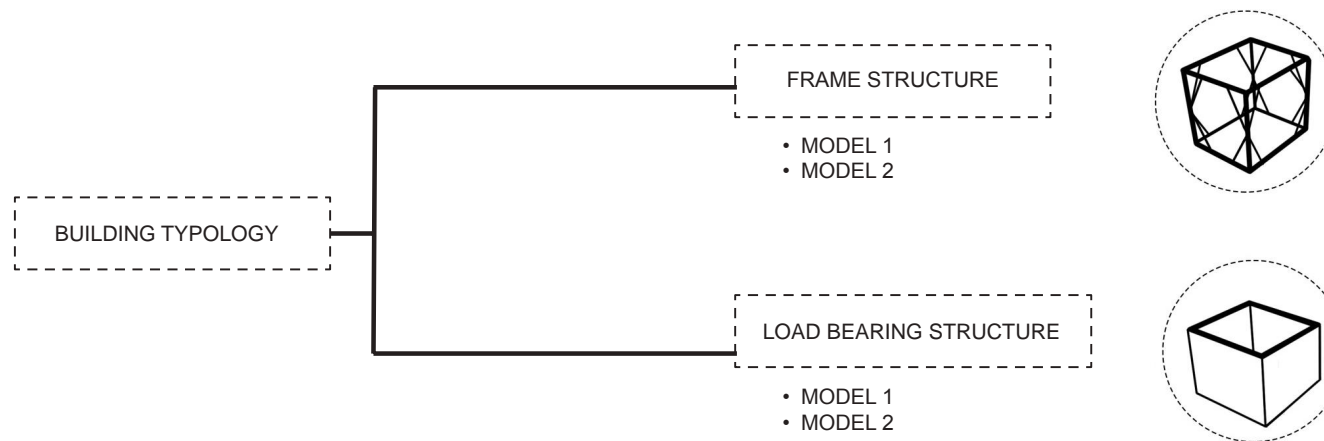





## 2.6.1.2 Plan

### MODEL 1

The typical house plan is designed considering three planar basis:

**1. Engineering Basis:** A standardized 7"x7" hollow column with an optimized center to center spacing which also ensures the local measuring practice

(1 haat= 1'6"). Thus the longer side of the house is 22'6"=15 haat and shorter side is 10'6"=7 haat.

**2. Anthropometric Basis:** The model 1 house covers an area of 236.25 sft. Maintaining the minimum sphere standard of 3.5 m<sup>2</sup> space per person and thus ensures 6 no's of person per house. Dimension of the houses can be altered according to the habitants preferences considering the structural feasibility.

**3. User Friendliness:** The modular form of house plan gives greater flexibility for future expansion, quick installation and dismantling features as well.

The following plans show different possible spatial organizations for single or multiple families:

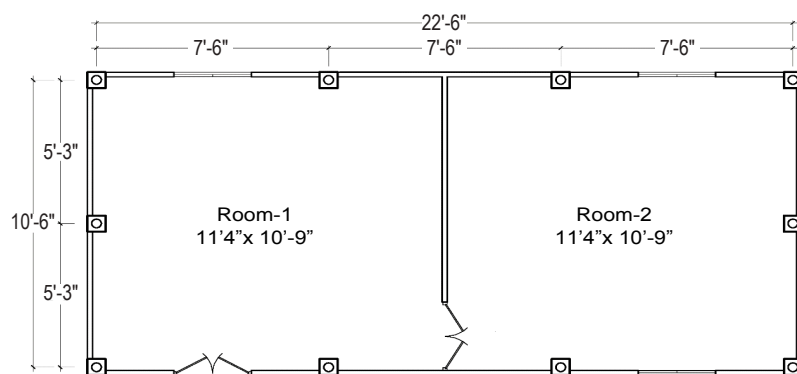

Plan ( Arrangement 1\_for single family)

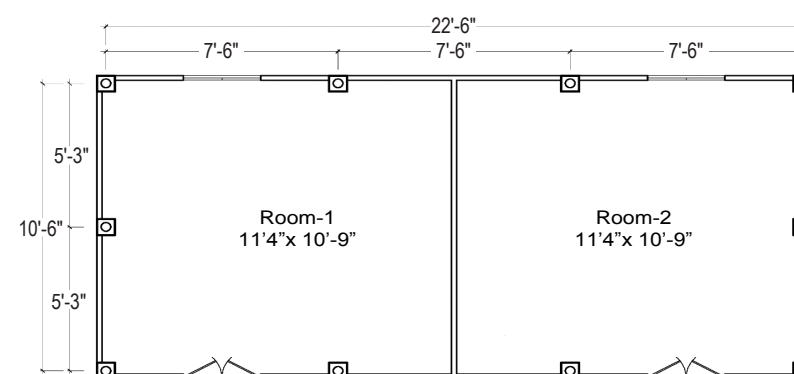

Plan ( Arrangement 2\_for two families)

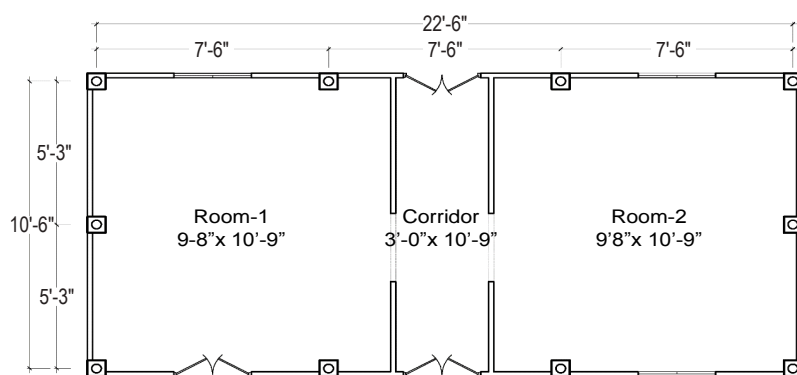

Plan ( Arrangement 3\_for single/ two families)

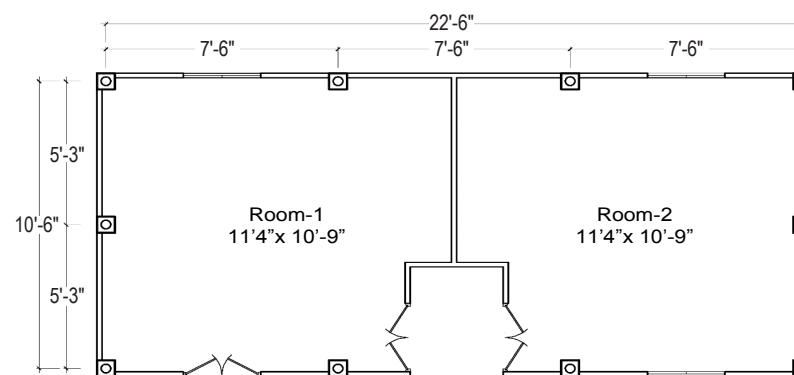

Plan ( Arrangement 4\_for two families)

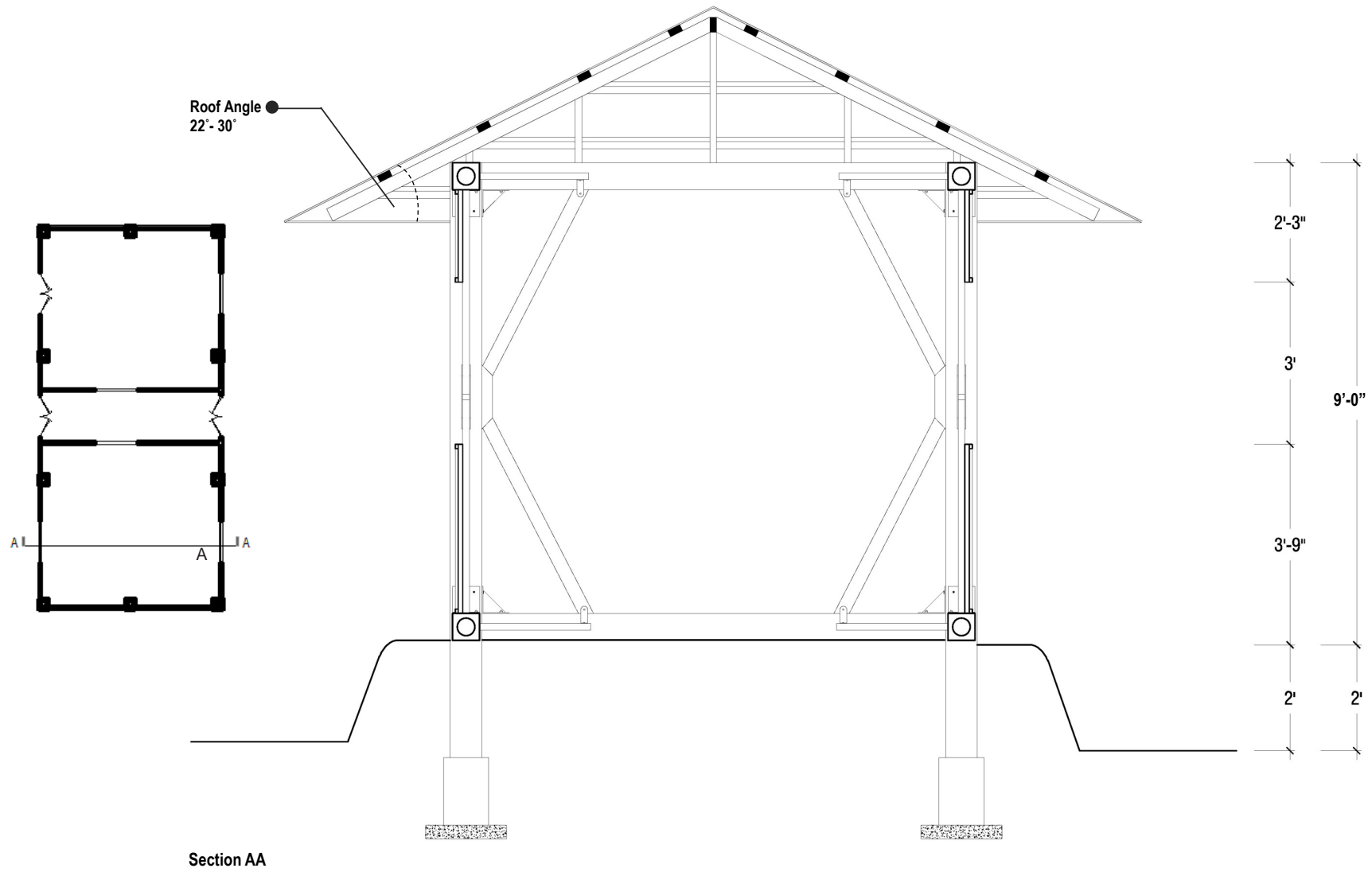

## SECTION OF FRAME STRUCTURE HOUSE PLAN WITH PASAHCHATI

In order to achieve more resistance against cyclone, the typical house plan can be generalized into two layers; outer layer known as “pashchati” and the main internal layer, known as “ghar”. Some houses have “Pashchati” on all sides and some have on 2-3 sides of the main “ghar”. But, whatever the number is, the Pashchati should be placed on the windward side. In addition, careful construction of the surrounding “Pashchati” will reduce the wind pressure towards the hip roof over the “ghar”. The roof of the main “ghar” and “Pashchati” are built separately for the safety of the main roof. Moreover, minimum roof overhangs and low openings in the front “Pashchati” wall prevent roof uplift from wind pressure. Hip roofs are more resistant to wind pressure than general pitched roof so it is recommended to have hip roof for houses. Moreover, the roofs of the “Pashchati”, and “ghar” should be kept separate for the safety of the main inner area. The dimension of the “ghar” remains same as shown in previous plans. The feature, Pashchati has this inherent merit of accommodating various household service requirements like kitchen, stores, chicken coop, sleeping facilities for few if necessary etc.

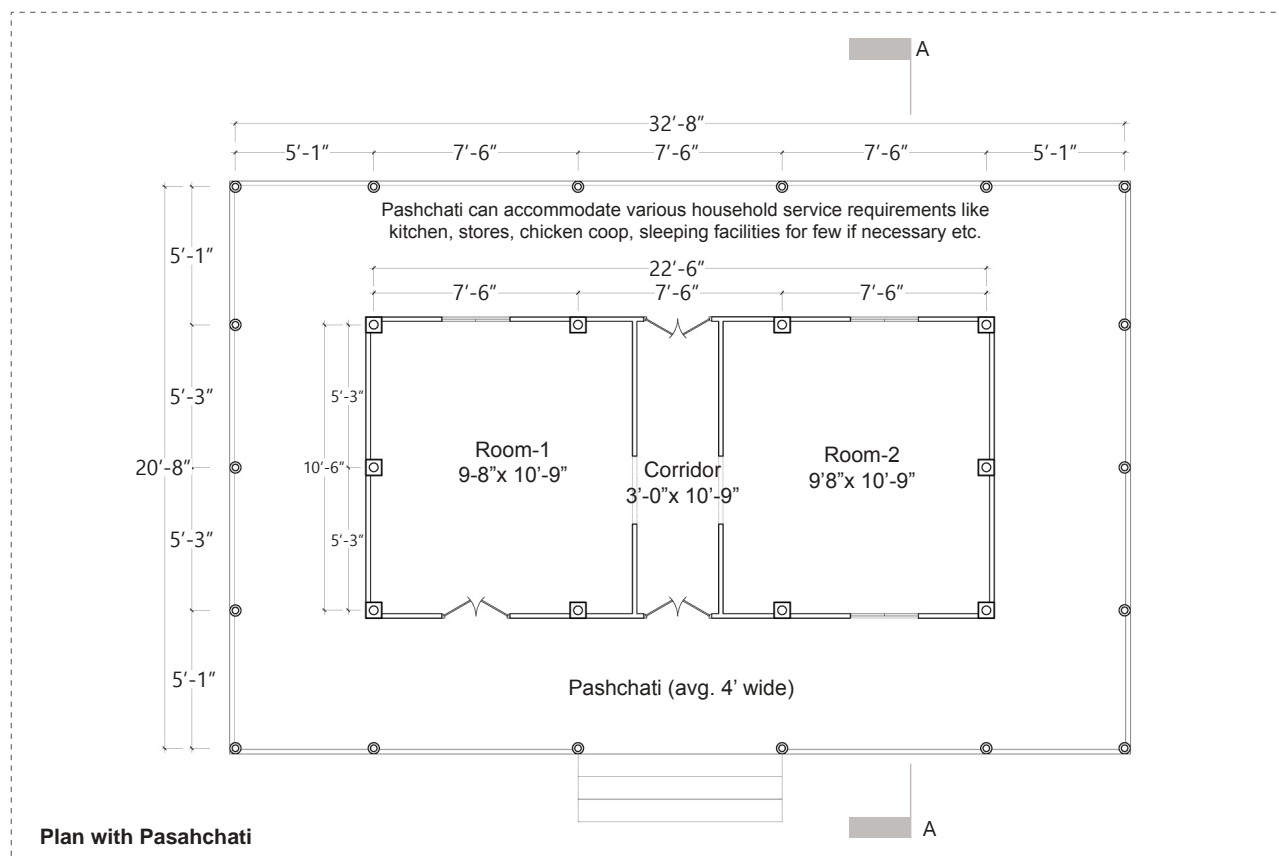

Plan with Pasahchati

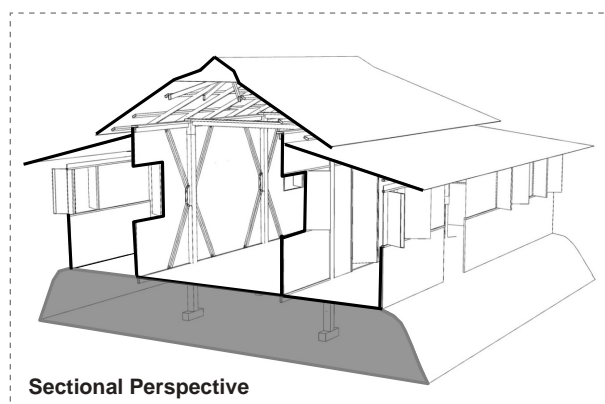

Sectional Perspective

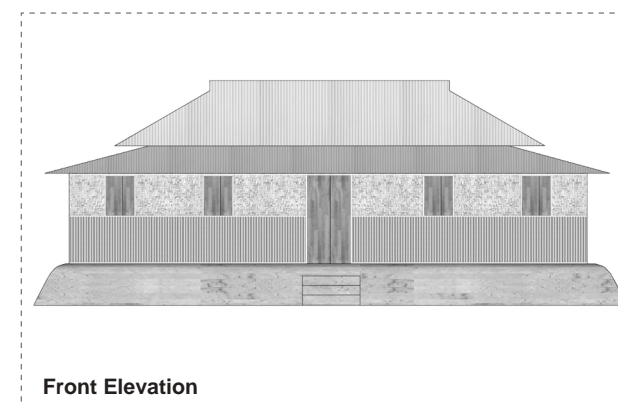

Front Elevation

## TOTAL HOUSE-PASHATI SECTION

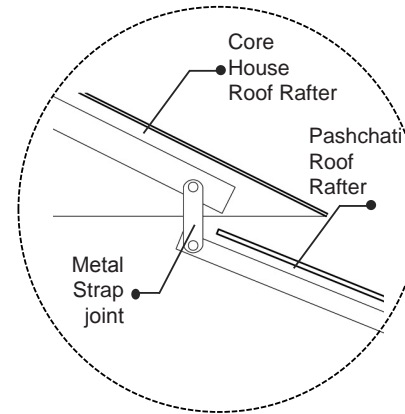
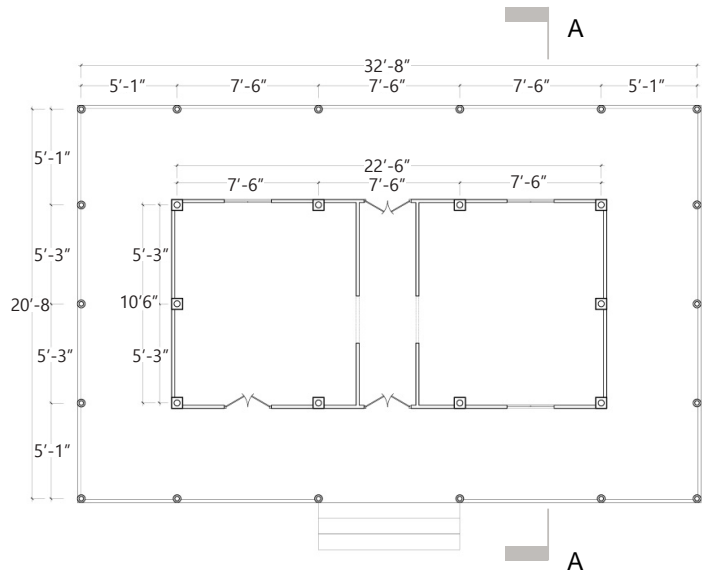

The framework of the Pashchati roof should be well secured with that of the main house unit roof by employing proper joineries comprising of metal strap joints or other similar strong connections

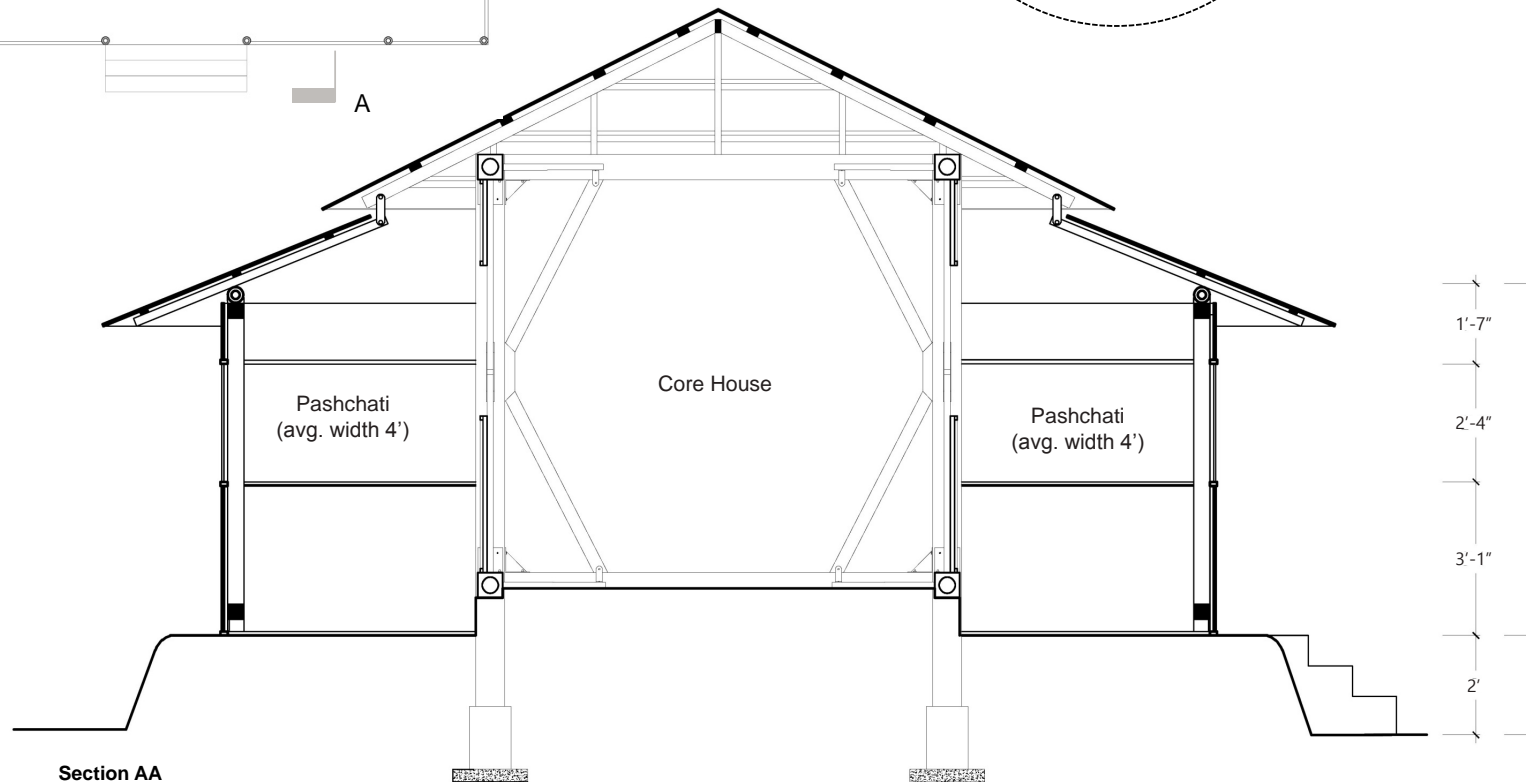



## TYPICAL FRONT ELEVATION OF FRAME STRUCTURE HOUSE



## FORMATION OF HOUSE MODULE

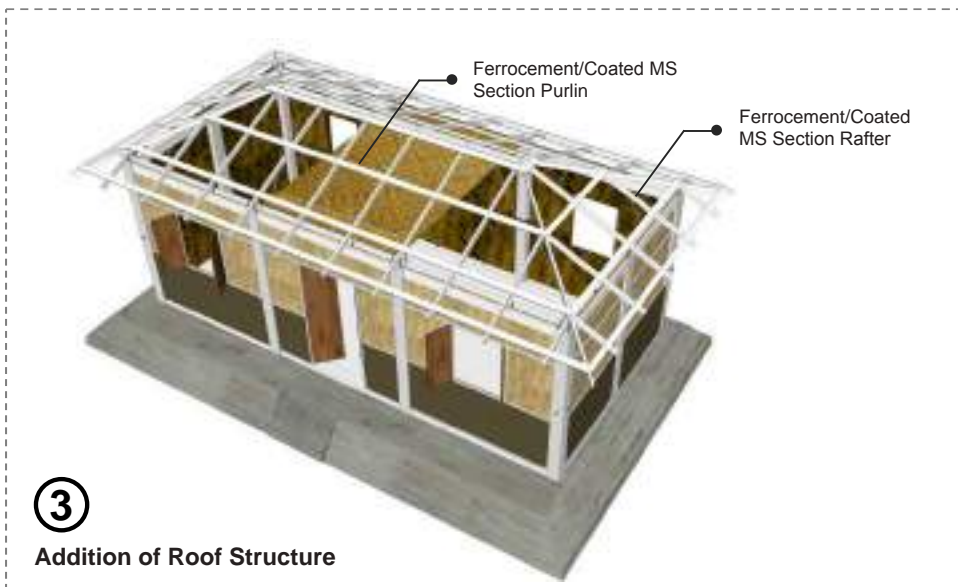
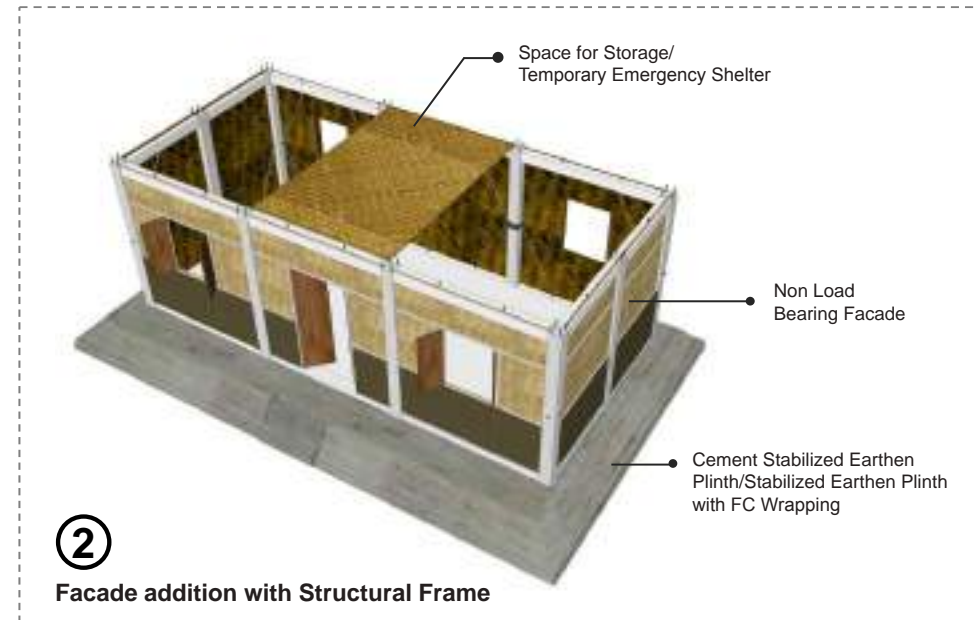
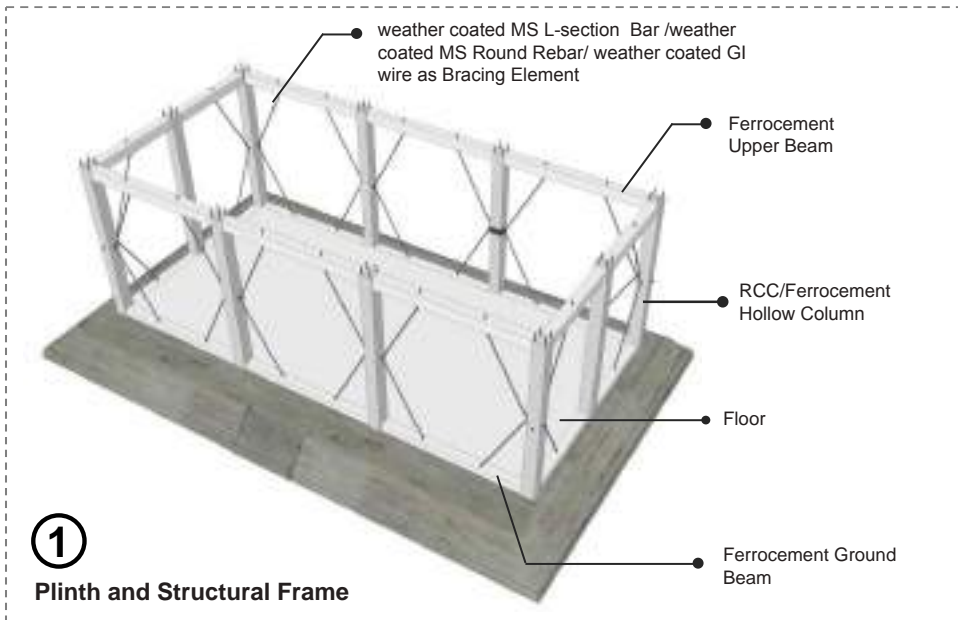

## HOUSE FORM MODEL 1



## FORMATION OF HOUSE MODULE WITH PASHCHATI

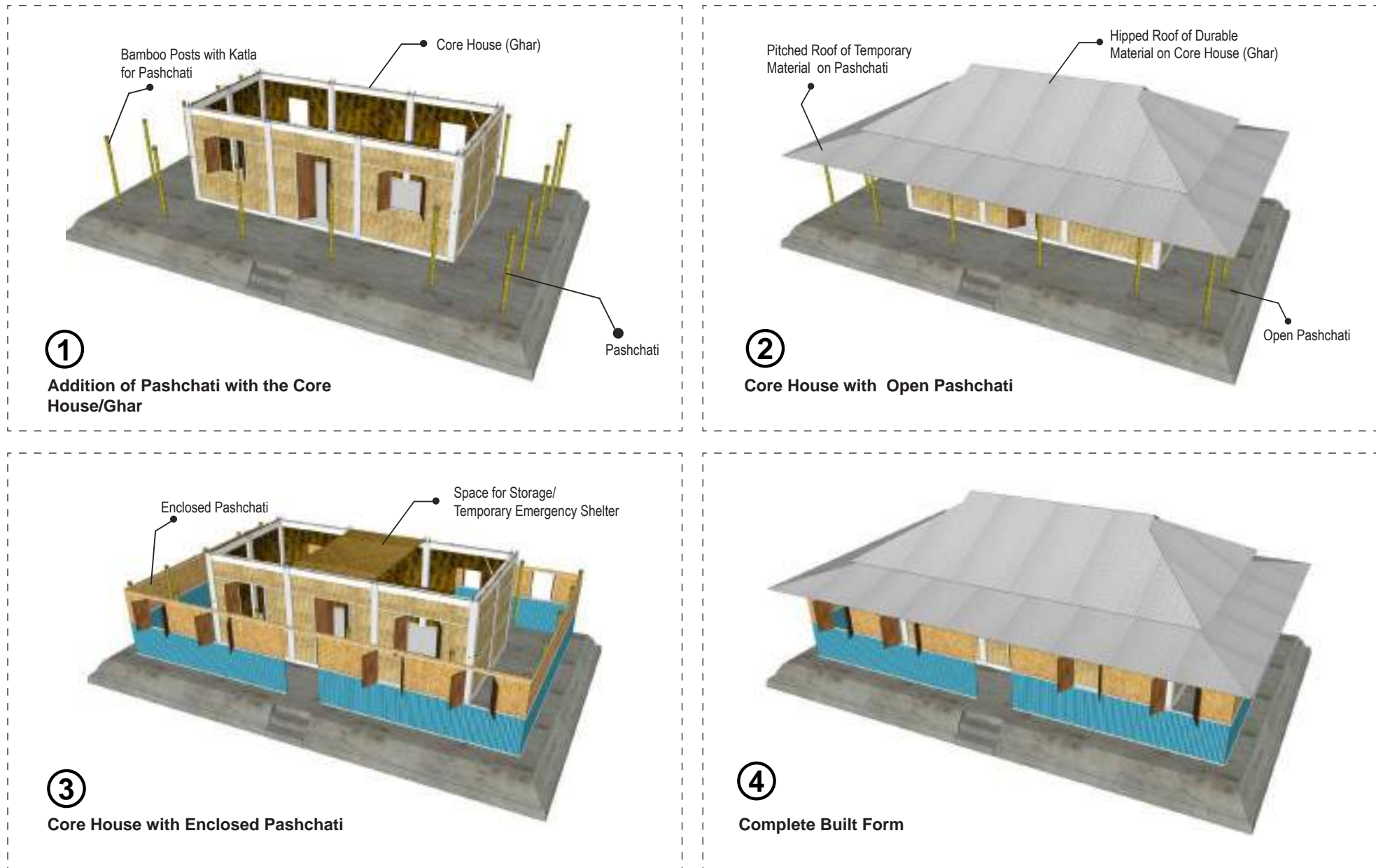



## MODEL 2

Model 2 is relatively small, single family and open plan dwelling unit (15'-0"x10'-6") where interior spaces can be organized according to inhabitant's need. The planar basis is same as model 1. It

covers an area of 157.5 sft. maintaining the minimum sphere standard of 3.5 m<sup>2</sup> space per person and thus ensures 4 no's of person per house. it can be expanded as per inhabitant's requirement and can be formed into model 1. Construction stages are same as previous .

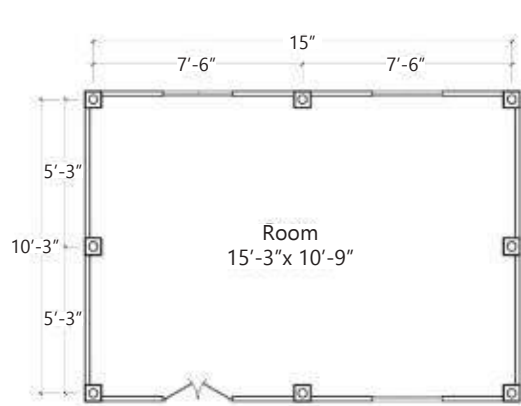

Plan (for single family)

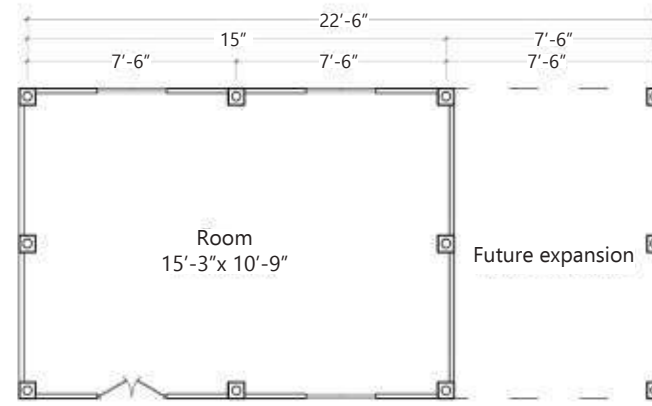

Expansion plan



Front elevation

## FORMATION OF HOUSE MODULE

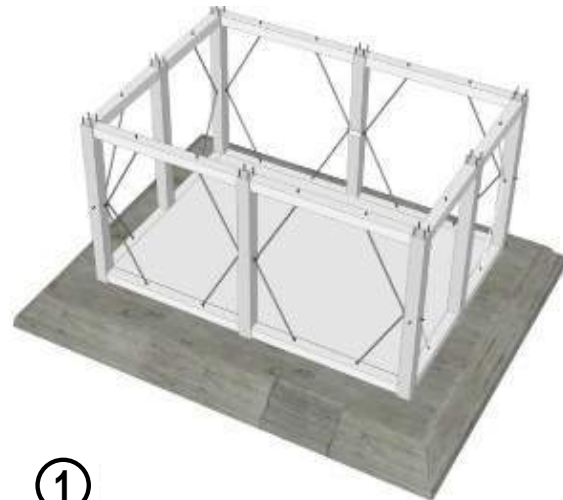

①

Plinth structural frame

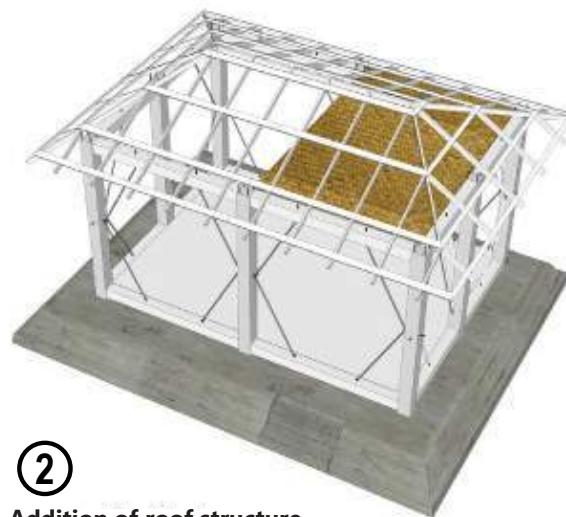

②

Addition of roof structure



③

Complete built form



### 2.6.1.3 Building Elements

#### 2.6.1.3A Structural Elements

##### RCC/FC Stump Pad Footing:

In Cyclone prone areas the house is to be firmly tied to the ground, to avoid it flying off, starting by connecting the roof well to the columns, the columns well to the foundation and anchoring the foundation well into the ground. The Ferrocement or RCC Stump Pad Footing can act well to anchor the built form.

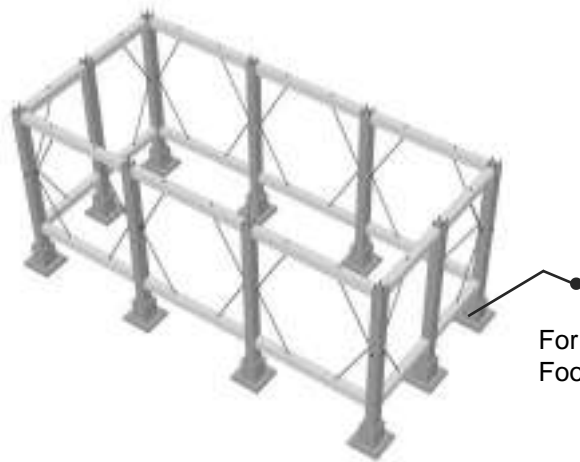

For Stump Pad Footing See detail 1



Detail 1

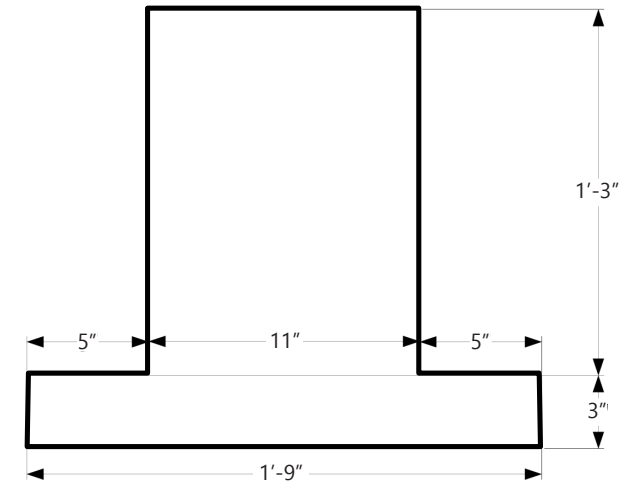

Elevation of stump pad footing

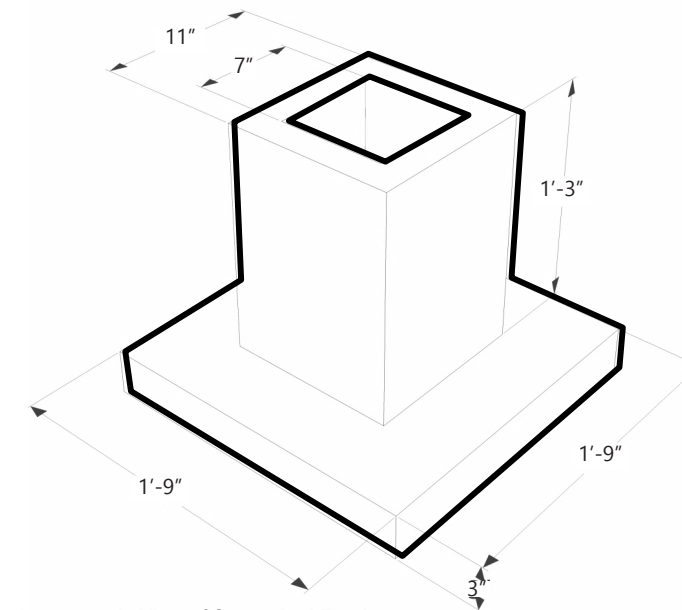

Axonometric View of Stump Pad Footing

## COLUMN

RCC or Ferrocement Hollow Column (7"x 7" with  $\emptyset$  4" hollow inside) is used as structural element. These columns are inserted into stump pad footing by:

- ▶ Screw Hardware or
- ▶ Non-shrink Grout

For Ferrocement Column, 4 nos. of 6mm $\emptyset$  bars, 1 layer of 20 BWG wire mesh and 3mm $\emptyset$  @ 7" c/c tie rods are used. Cement Sand ratio is maintained within 1:3.

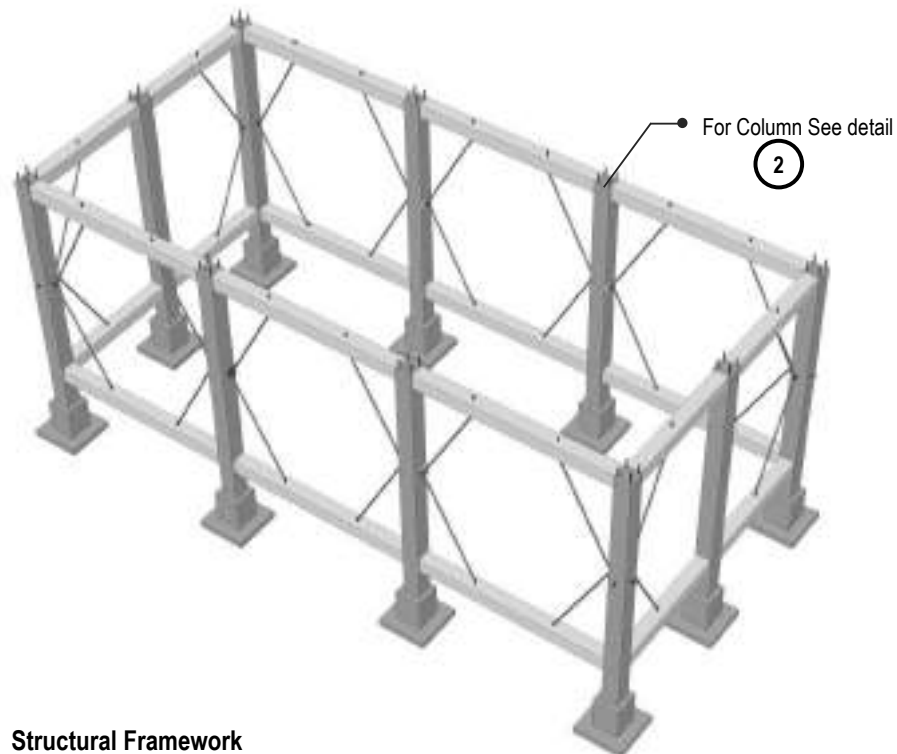

Structural Framework

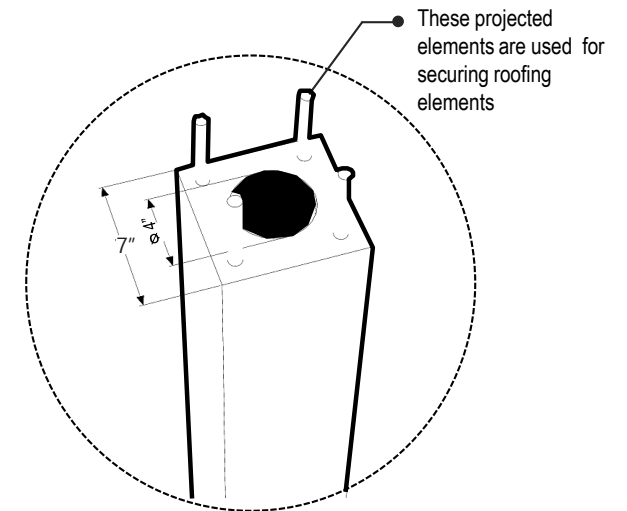
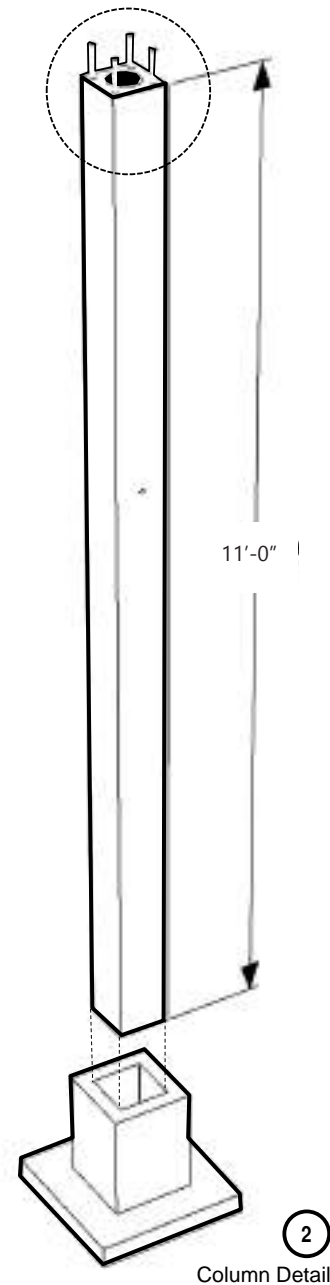

2 Blow up of Column Head



Ferrocement Hollow Column

## FERROCEMENT TOP BEAM

### Option 1: T-Beam

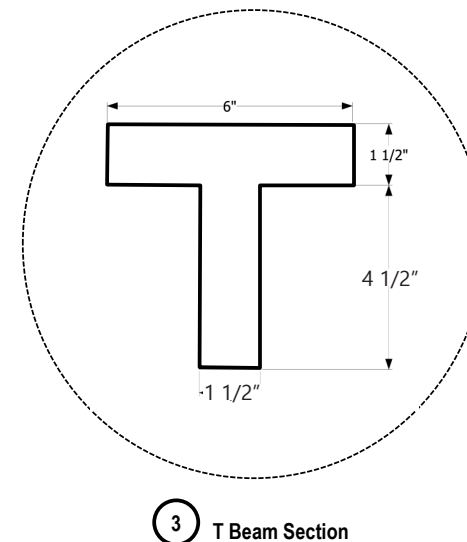
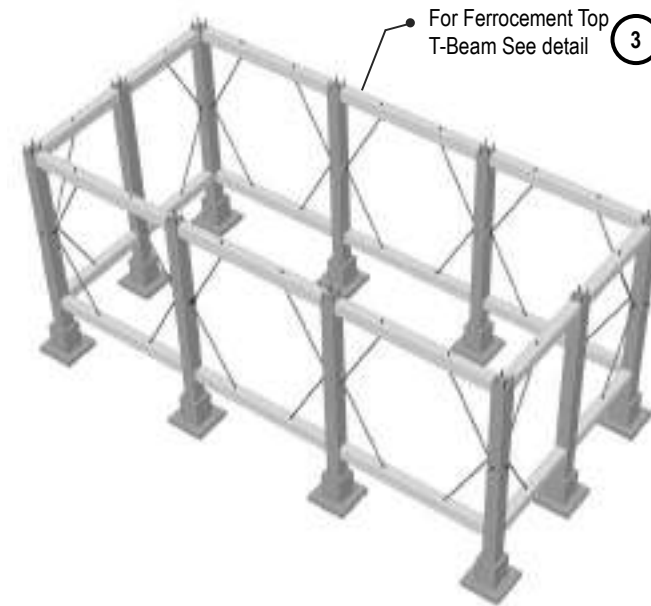
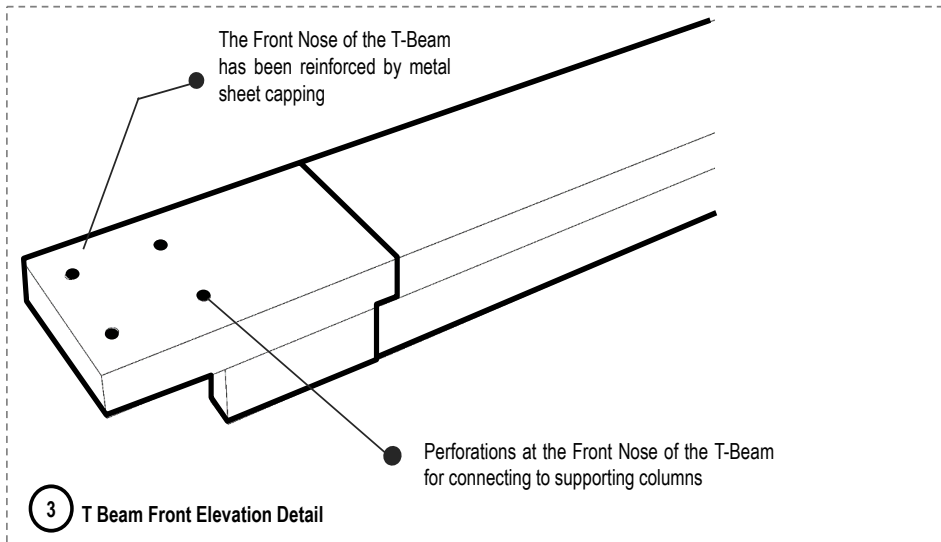
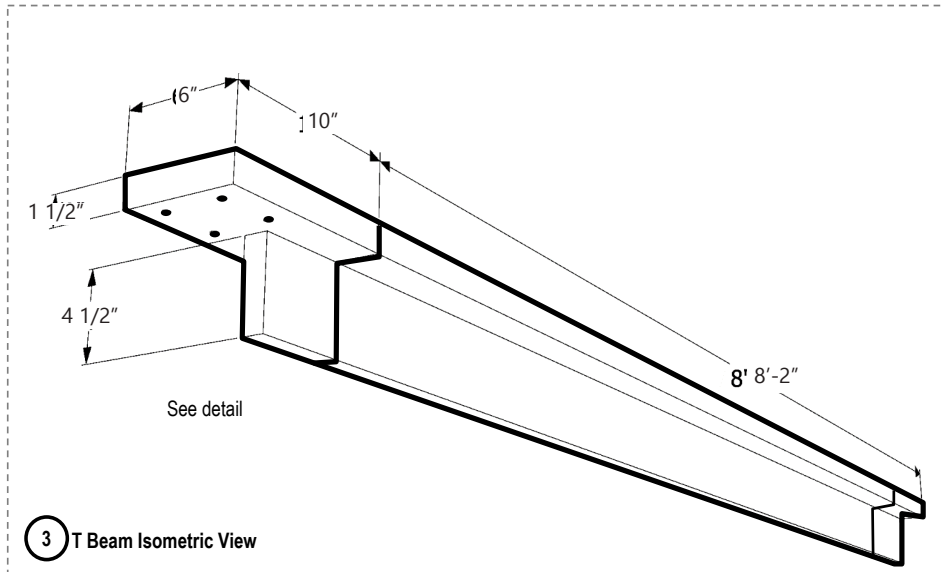

## FERROCEMENT TOP BEAM

### Option 2: Square Beam

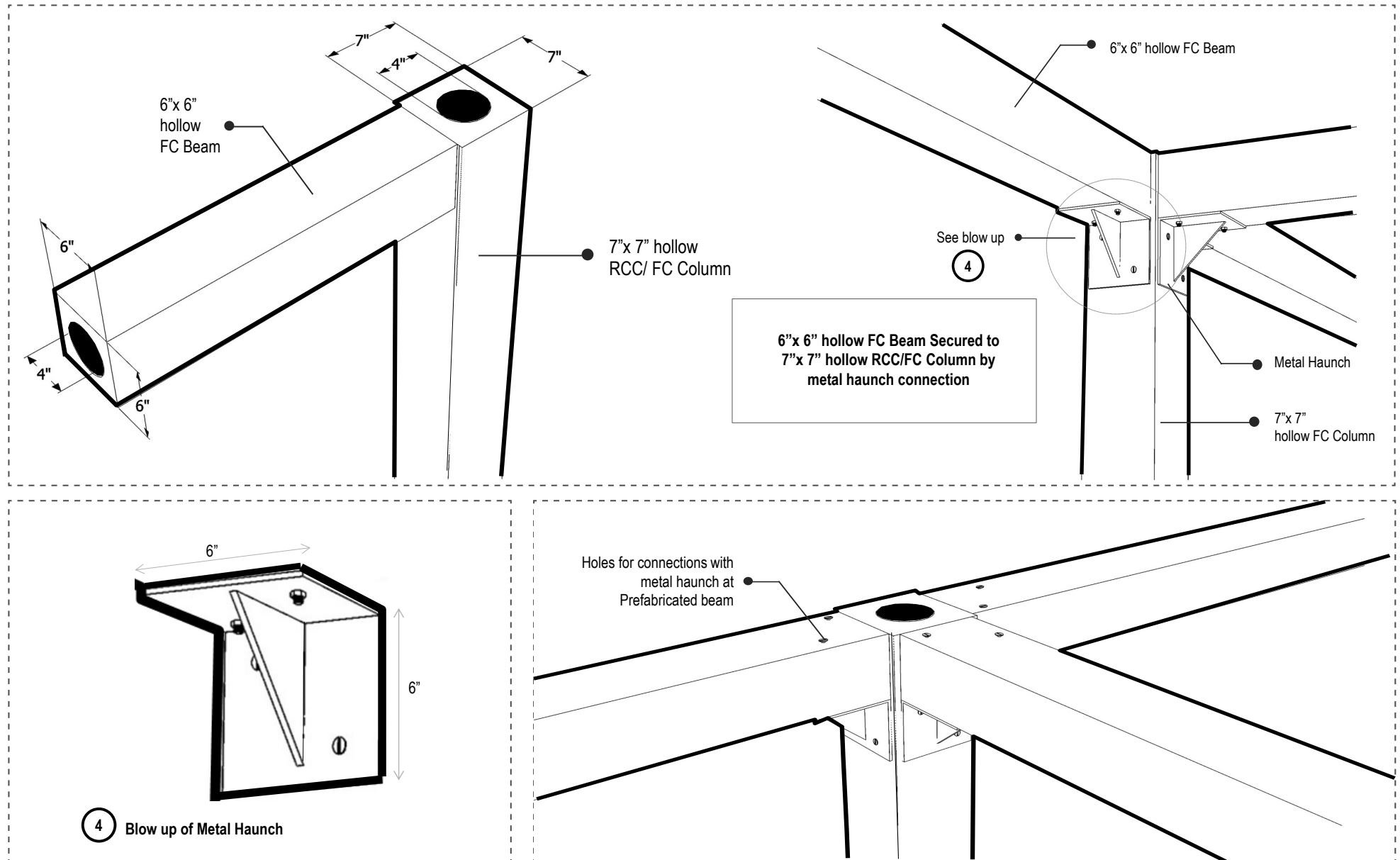

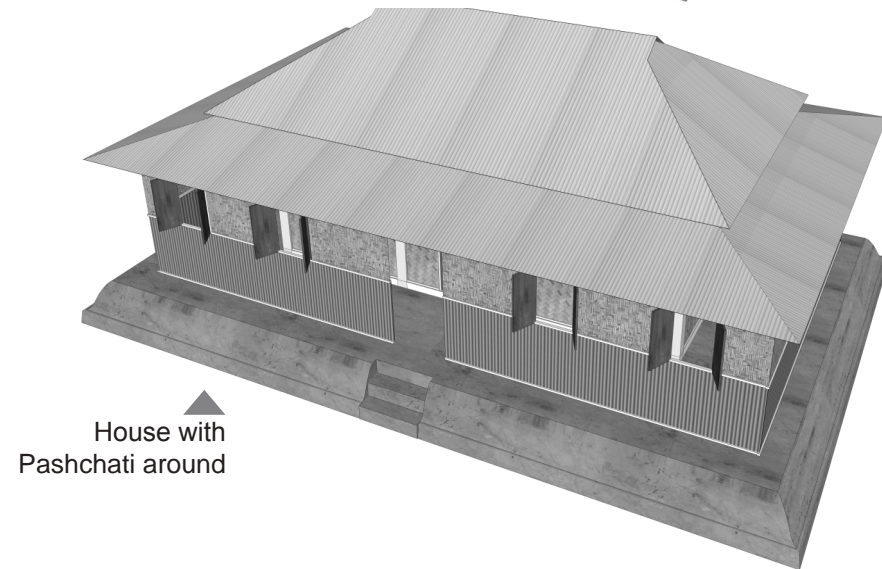
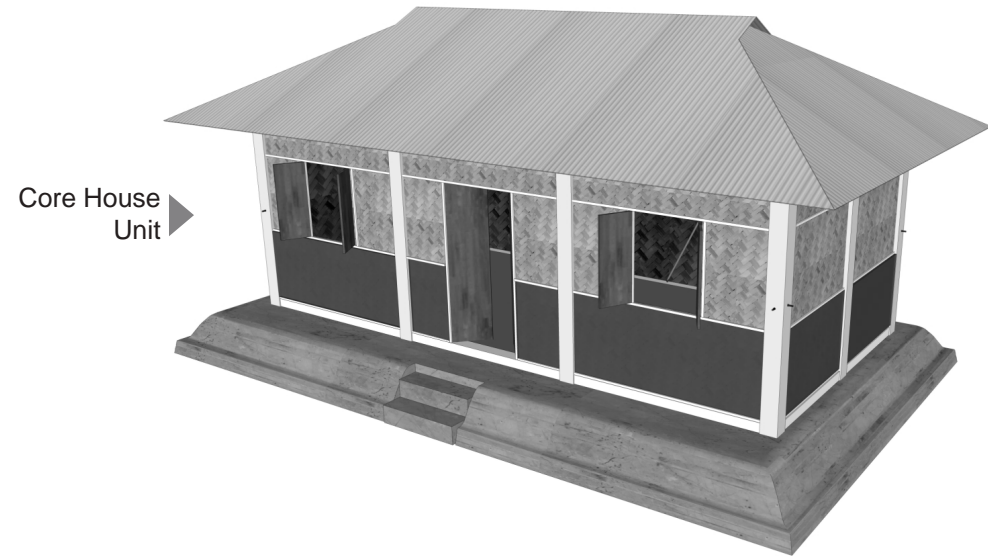

### 2.6.1.3B Facade Elements











Note: The given material options are suitable as infill materials. They could be used as facade material both for the core house unit and the Pashchati. However the lower part of the exposed facade is suggested to be built with more durable material than the organic ones considering the salinity, rain water, moisture and other issues.

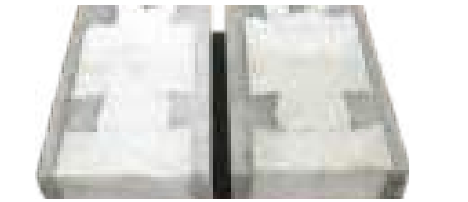



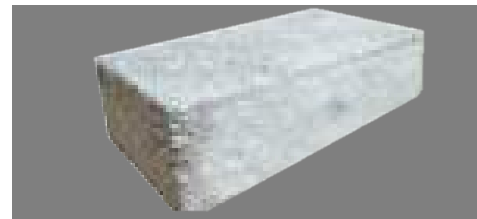

### 2.6.1.3C Specification for Facade Elements

SL	Material	Description	Specifications	Cost	Image
1.	Ferrocement	<ul style="list-style-type: none"> <li>▶ Ferrocement is ideally suited for thin wall structures as the uniform distribution and dispersion of reinforcement provide better crack resistance, higher tensile strength to-weight ratio, ductility and impact resistance.</li> <li>▶ Ferrocement elements can be divided into two categories based on the construction procedure- Cast-in-situ Pre- Cast</li> </ul>			 
	a. Cast-in-situ	<ul style="list-style-type: none"> <li>▶ Cast in situ ferrocement includes the procedure of constructing the element in the particular site.</li> <li>▶ Its difficult to maintain the size, shape and thickness of the element.</li> <li>▶ Labor charge is high.</li> <li>▶ Assembling cost is high in this type of construction.</li> </ul>	<ul style="list-style-type: none"> <li>▶ Cement :Sand=1:2.</li> <li>▶ Sylhet Sand having F.M 2.2- 2.6 is used as fine aggregate.</li> <li>▶ W/C=0.45.</li> <li>▶ Iron wire mesh= 2-layers of 18 BWG or 20 BWG with 1/2" opening.</li> <li>▶ Skeleton rod=8mmφ(both way) @2'c/c</li> </ul>	Cost per unit = 135 Tk/sft	
	b. Pre-cast	<ul style="list-style-type: none"> <li>▶ Ferrocement pre cast element can be constructed at convenient places (e.g. factory, workshops) and transported to the sites .</li> <li>▶ Its easy to move from the place of manufacturing to the construction site.</li> <li>▶ Labor charge is comparatively low.</li> <li>▶ Less efforts are required to maintain the size, shape and thickness of the element.</li> <li>▶ In order to avoid the issues related to salinity in coastal areas pre cast ferrocement elements can be proved to be more preferable.</li> </ul>	<ul style="list-style-type: none"> <li>▶ Cement :Sand=1:2</li> <li>▶ Sylhet Sand having F.M 2.2- 2.6 is used as fine aggregate.</li> <li>▶ W/C=0.38-0.45</li> <li>▶ Iron wire mesh= 2-layers of 18 BWG or 20 BWG with 1/2" opening.</li> <li>▶ Skeleton rod=8mmφ(both way) @2'c/c.</li> </ul>	Cost per unit = 120 Tk/sft	
2.	3D Panel	<ul style="list-style-type: none"> <li>▶ 3D panel is a prefabricated panel, which consists of a super-insulated core of rigid expanded polystyrene, sandwiched between two sheets of steel welded wire fabric mesh.</li> <li>▶ 2.5 mm diameter galvanized steel truss wire is pierced through the polystyrene core at offset angles for superior strength and integrity and welded to each of the outer layer sheets of eleven-gauge steel welded wire fabric mesh.</li> </ul>	<ul style="list-style-type: none"> <li>▶ Total thickness of mortar(Cement: Sand=1:3) on interior and exterior faces = 62.5 mm</li> <li>▶ Sylhet Sand having F.M 2.2- 2.6 is used as fine aggregate.</li> <li>▶ W/C= 0.45</li> <li>▶ Diameter of welded wires= 2.5 mmφ</li> <li>▶ Thickness of expanded polystyrene sheet= 37.5 mm</li> <li>▶ Total finishing thickness= 100mm</li> </ul>	Cost per unit =182 Tk/sft	

SL	Material	Description	Specifications	Cost	Image
3.	Sandwich Panel	The sandwich panels are consisted of two thin ferrocement layers, reinforced with one layer of iron wire mesh, with core(middle part)made of Expanded Polystyrene Sheet.	<ul style="list-style-type: none"> <li>▶ Total thickness of the concrete(cement: sand=1:3) on interior and exterior faces = 25 mm</li> <li>▶ Sylhet Sand having F.M 2.2- 2.6 is used as fine aggregate.</li> <li>▶ W/C= 0.45</li> <li>▶ Iron wire mesh= 18 BWG with ½ " opening.</li> <li>▶ Thickness of expanded polystyrene sheet (density-15kg/m3)= 56.25 mm</li> <li>▶ Total finishing thickness= 87.5mm</li> </ul>	Cost per unit = 135 Tk/sft	
4.	Compressed Stabilized Earth Block (CSEB)	<ul style="list-style-type: none"> <li>▶ Compressed stabilized earth block (CSEB) or a compressed soil block, is a building material made primarily from dredged soil compressed at high pressure to form blocks.</li> <li>▶ The dredged soil is being collected from Kapatakha, Shurma and Feni river.</li> </ul>	<ul style="list-style-type: none"> <li>▶ Size: 9.5" ×4.5" ×3"</li> <li>▶ Compressive strength: 1000psi (dhaka soil) and 650 psi(kapatakha soil).</li> <li>▶ Mix proportion:10% cement and 90% dredged soil</li> </ul>	Cost per unit =3,282 Tk/cum	
5.	Thermal Block	<ul style="list-style-type: none"> <li>▶ Thermal block is the composition of Expanded Polystyrene Sheet and Mortar(Cement and Sand).</li> <li>▶ Commonly used as facade material.</li> <li>▶ Improves the thermal property of indoor environment. Can be used in frame structures.</li> <li>▶ Lightweight though reduces overall mass of the structure.</li> </ul>	<ul style="list-style-type: none"> <li>▶ Cement:Sand= 1:4</li> <li>▶ Sylhet Sand having F.M 2.2- 2.6 is used as fine aggregate.</li> <li>▶ Size: 9.5" ×4.5" ×2.75"</li> <li>▶ Compressive strength: approximately 750 psi.</li> </ul>	Cost per unit =135 Tk/sft	
6.	CLC Block	<ul style="list-style-type: none"> <li>▶ Cellular Light Weight Concrete (CLC) is a version of light weight concrete that is produced like normal concrete under ambient conditions.</li> <li>▶ It is 50% Lighter than normal brick</li> </ul>	Size: 20" ×8" ×4"	Cost per unit = 5,768.82 Tk/cum	
7.	Organic/ Bamboo mat (Non plastered/plastered)	Typically in kutchra houses; semi-pucca houses also often have bamboo mat walls. Organic materials (e.g. jute stick, catkin grass) have a lifespan of 2-3 years and bamboo matt 4-5 years. Decay can get accelerated in flood. In flood of high depth and moderate duration, the damage begins in the lower part of walls and hence weakens the walls and eventually results incomplete damage. Flood with strong currents can detach wall panels and wash them away, leading to partial or complete loss, especially if the connections to posts are weak.	Size: can be of any effective size.	<ul style="list-style-type: none"> <li>▶ Cost per unit= 20 Tk/sft (non-plastered)</li> <li>▶ Cost per unit= 807 Tk/sqm (plastered)</li> </ul>	

SL	Material	Description	Specifications	Cost	Image
8.	CGI Sheet	CGI or Corrugated Galvanized Iron is a building material composed of sheets of hot-deep galvanized mild steel, cold-rolled to produce a linear corrugated pattern in them. The corrugations increase the bending strength of the sheet in the direction perpendicular to the corrugations, but not parallel to them. Normally each sheet is manufactured longer in its strong direction. CGI is lightweight and easily transported. Corrugated iron is equivalent to tin roof.	<ul style="list-style-type: none"> <li>▶ Minimum Thickness= 0.35 mm</li> <li>▶ Approximately Weight per bundle =55 kg</li> <li>▶ Width of Sheet =875 mm (Tolerance +/- 10 mm)</li> <li>▶ Length per bundle approximately =72 feet</li> </ul>	Cost per unit = 127 Tk/sft	
9.	Sand Cement Hollow Block	<ul style="list-style-type: none"> <li>▶ These blocks are produced by combining sand and cement .Low Maintenance, Color and brilliance of masonry withstands outdoor elements.</li> <li>▶ Strength can be specified as per the requirement.</li> <li>▶ Reduce in total cost of project by being less in dead load of walls.</li> </ul>	<ul style="list-style-type: none"> <li>▶ Size: 9.5" ×4.5" ×8"</li> <li>▶ Sylhet Sand having F.M 2.2- 2.6 is used as fine aggregate.</li> </ul>	Cost per unit = 60 Tk/sft	
10.	Poly block with EPS Bubble	<ul style="list-style-type: none"> <li>▶ Made from sand, cement, EPS bubble and foaming agent.</li> <li>▶ Reduce in total cost of project: - Being less dead load of walls.</li> <li>▶ Reduce in total cost of project: - Being less dead load of walls.</li> </ul>	<ul style="list-style-type: none"> <li>▶ Size: 9.5" ×4.5" ×3"</li> <li>▶ The residue of expanded polystyrene is used as poly bubble.</li> </ul>	Cost per unit = 60 Tk/sft	
11.	Interlocking Block	Interlocking blocks are like 2 adjoining pieces of a jigsaw puzzle. Each block has a projection at one end and a depression at the other. The projection of one block fits in to the depression of the next so that they always align perfectly.	<ul style="list-style-type: none"> <li>▶ Size: 9.5" ×4.5" ×3"</li> <li>▶ Mix Proportion:10% cement and 90% dredged soil.</li> </ul>	Cost per unit =30.00 Tk/sft	
12.	Aerated Concrete Block	<ul style="list-style-type: none"> <li>▶ Autoclaved cellular concrete (ACC) is made with fine aggregate, cement, and an expansion agent that causes the fresh mixture to rise like bread dough.</li> <li>▶ ACC materials use thin bed mortar in thicknesses around 1/8 inch, depending on the national building codes.</li> <li>▶ Lighter in weight than normal brick.</li> </ul>	Size: 9.5" ×4.5" ×5.5"	Cost per unit =25 Tk/sft	

## 2.6.1.3D Roofing Elements

SL	Material	Description	Specifications	Cost	Image
1.	Ferrocement Folded Plate	Folded plates with a trapezoidal cross-section either in the form of a 'hat' or in the form of a trough section give rigidity, ensure safety while handling to a large depth, and an inclined web with a large tension flange to accommodate reinforcements, lending for suitably pre casting / prefabricating.	Size: Flange width=5" Thickness=3/4" Maximum Depth=6" Length= Usually 10'6"(Can be changed as per requirement)	Cost per unit =175.00 Tk/sft	
2.	Ferrocement Corrugated Sheet	<ul style="list-style-type: none"> <li>▶ Ferrocement corrugated sheets can be used as mono pitched, gable or hipped roofing element.</li> <li>▶ It is suitable for coastal areas due to its non corrosive property.</li> <li>▶ Its thicker section, compared to conventional CI sheet, helps to withstand high wind pressure in coastal areas</li> </ul>	Size: Thickness=3/4" Length= 12'6"(Can be customized as per design requirements)	Cost per unit =171.00 Tk/sft	
3.	Cast in-situ Ferrocement Roof	<ul style="list-style-type: none"> <li>▶ Ferrocement roof shall transfer much less heat as compared to cement sheet/ CGI sheet roof.</li> <li>▶ It can be fully insulated against heat transfer.</li> <li>▶ Joint less ferrocement roof prevent humidity transfer inside.</li> </ul>	Size and Length can be changed as per requirements.	Cost per unit = 135.00 Tk/ sft	
4.	Ferrocement L-Panel	▶ Pre cast ferrocement L panel is a prefabricated L-shaped roofing element consists of full span RC ribs with wider legs as flanges, which is made of ferrocement.	Size: Rib Depth= 5" Rib width= 2" Flange width=21" Flange Thickness=3/4" Provision of 3/4 -1 in groove in the flange/top of the rib along the length is made for laps over the adjacent units.	Cost per unit =188.00 Tk/sft	
5.	Ferrocement Precast Channel	<ul style="list-style-type: none"> <li>▶ A pre cast ferrocement channel roofing element is a trough-shaped element flange, which is made of ferrocement and ribs are of reinforced concrete.</li> <li>▶ The design principle is the same as that of the precast RC channel element.</li> </ul>	Size: Width= 2ft(including rib portions), Length=Usually 12'6"(Can be changed as per requirement ) Thickness: Flange thickness=3/4" Rib Thickness=2"	Cost per unit =254.00 Tk/sft	

### 2.6.1.3E Specifications for plinth

#### Different Plinth Profiles

##### I. Earthen Plinth with Cement Stabilization

- ▶ Stabilized earthen plinth can be prepared by mixing cement and sand together.
- ▶ The ratio of mix proportion is 1:10(Cement: Sand).
- ▶ The sand can be collected from the locality.

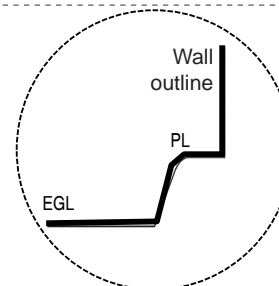

Profile-1

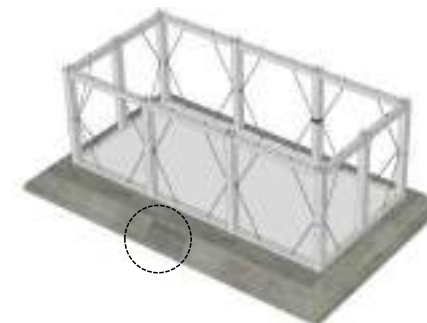

##### II. Earthen Plinth with Ferrocement Wrapping in Perimeter

- ▶ After the completion of earth work in the plinth level, ferrocement layer is used to wrap around the earthen plinth.
- ▶ This procedure ensures safety of the plinth area from corrosion as well as enhances durability.

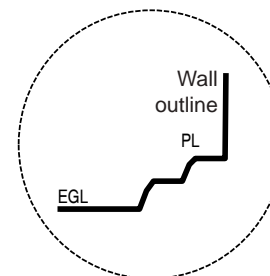

Profile-2

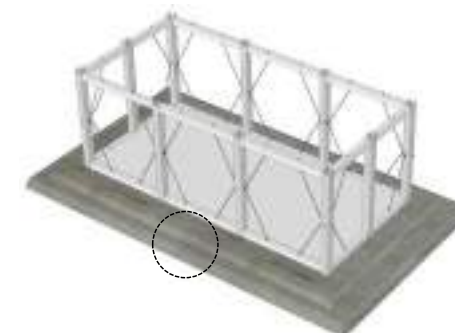

##### III. Alternative Blocks as Perimeter Wall

- ▶ After the completion of earth work in the plinth level, different blocks such as CSEB, aerated concrete block, sand cement hollow block, can be used in the perimeter.
- ▶ This practice ensures maximum protection of the plinth area with providing serviceability and durability, better than conventional earthen plinth.

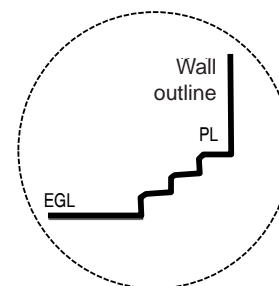

Profile-3

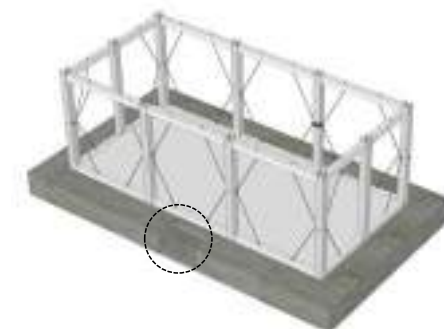



### 2.6.1.4 Technical Drawings

#### 2.6.1.4A Joinery Details

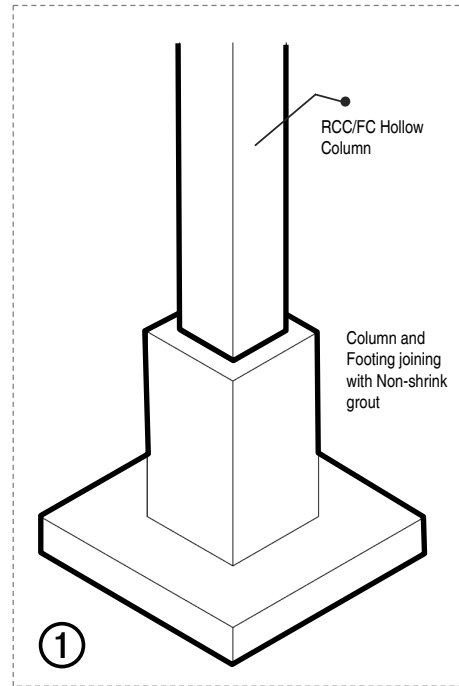
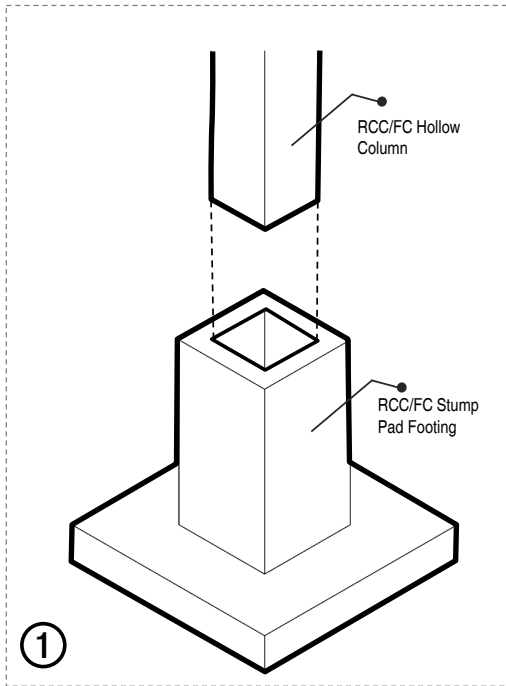

①  
RCC/FC Column joint with stump pad footing using non-shrink grout

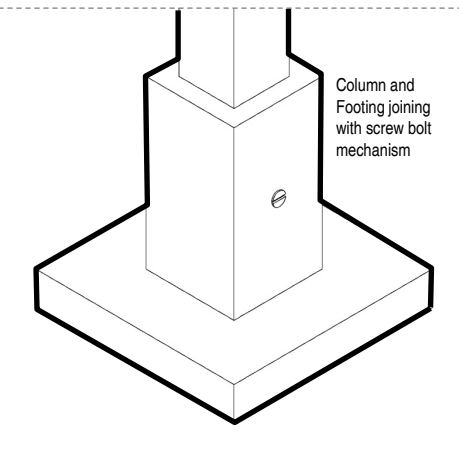
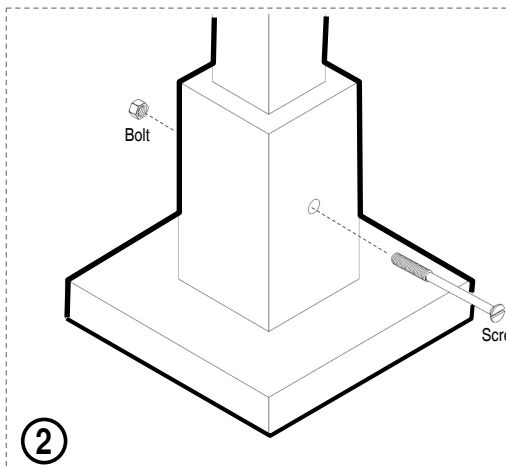

②  
RCC/FC Column joint with stump pad footing using screw joint

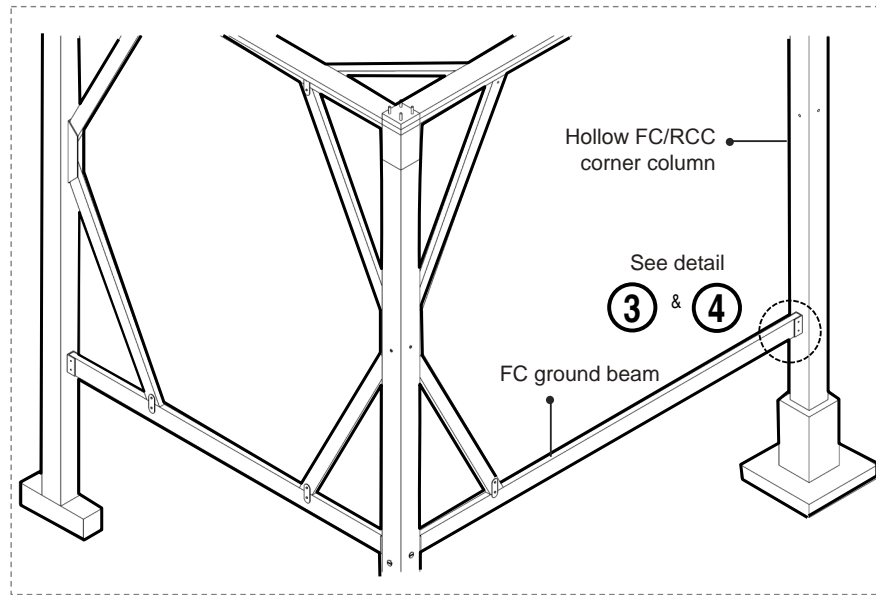

(3) + (4)

**Ferrocement Ground Beam and Metal Bracket Joint Detail**

Ground beam secured to supporting columns through metal bracket-cap joint. The joint detail between bottom beam end and metal bracket-cap feature has been shown at Figure 3 and 4.

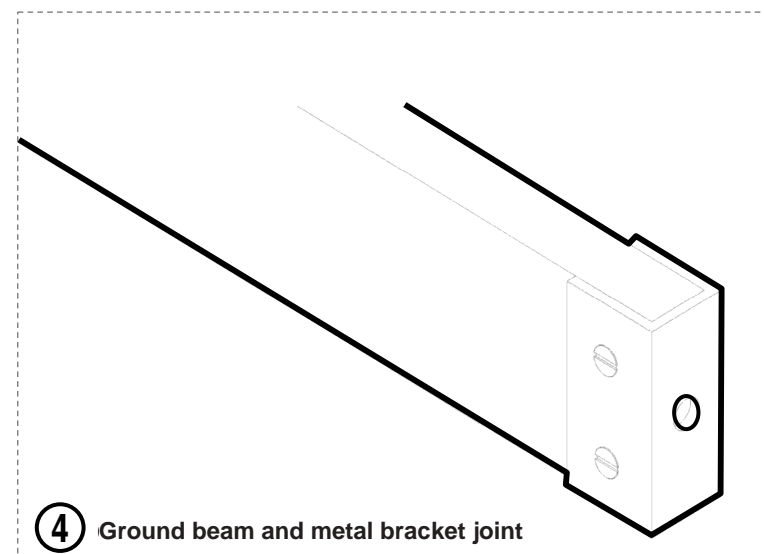
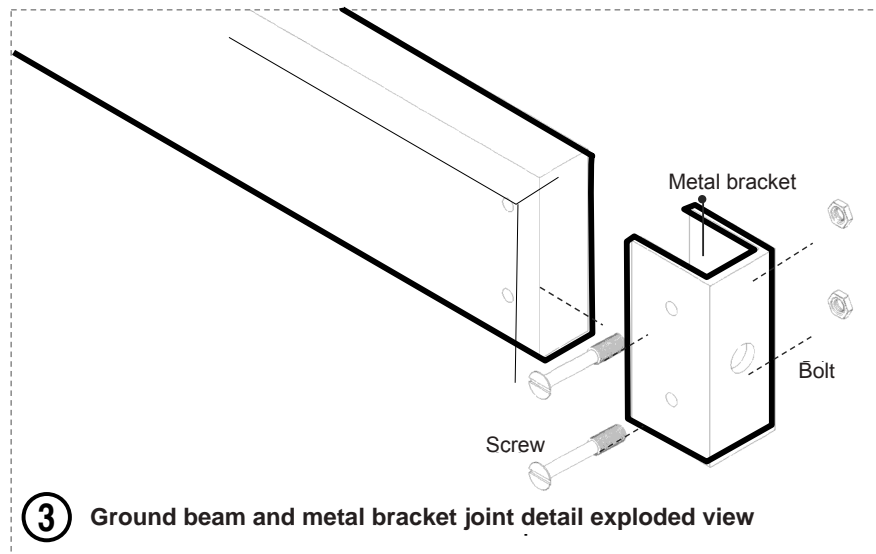

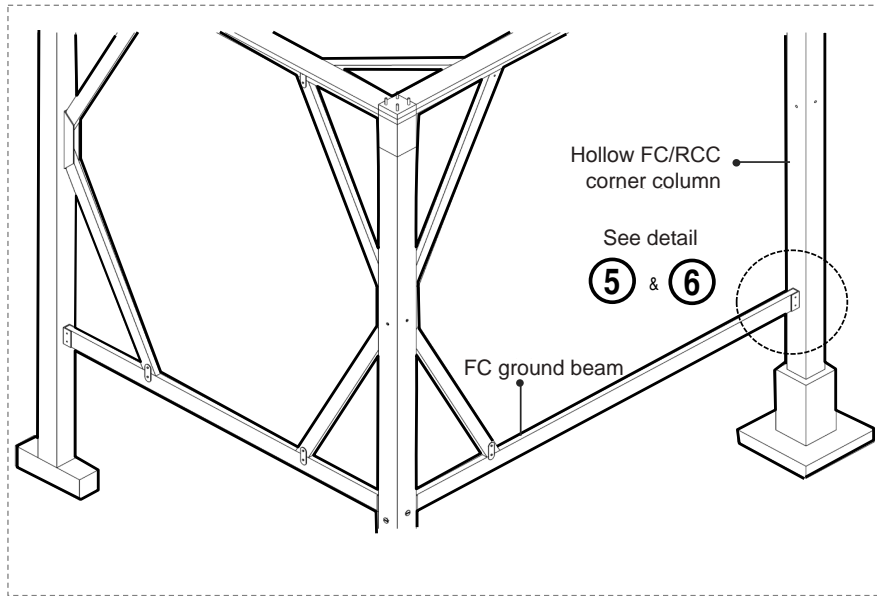

⑤+⑥

### RCC/ FC Column and FC Ground Beam Joint Detail

Ground beam secured to supporting columns through metal bracket-cap joint. The total assemblage of joint details between bottom beam end, metal bracket-cap and column has been shown at Figure 5 and 6.

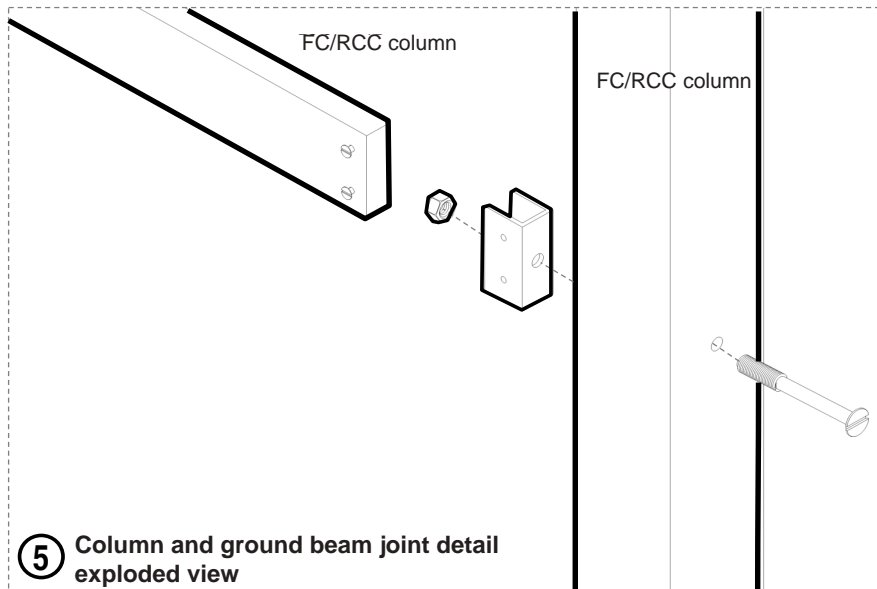

⑤ Column and ground beam joint detail exploded view

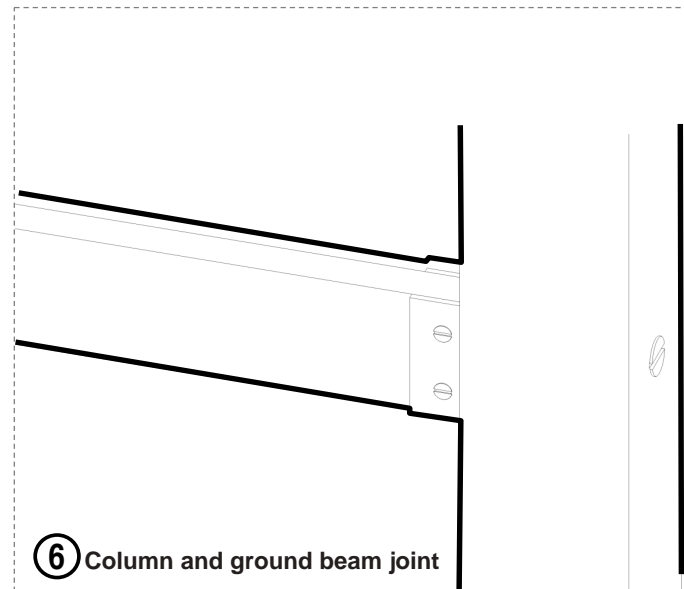

⑥ Column and ground beam joint

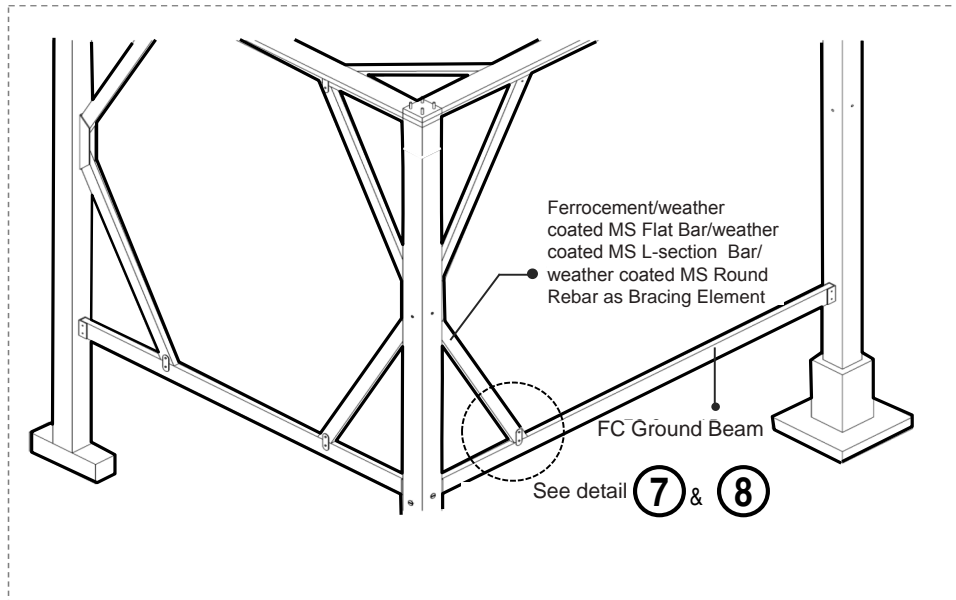

**(7) + (8)**

**Bracing and FC Ground Beam Joint Detail**

Bracing member secured to ground beam by flat MS bar bolted connectors. The total assemblage of joint details between bracing end and MS bar has been shown at Figure 7.

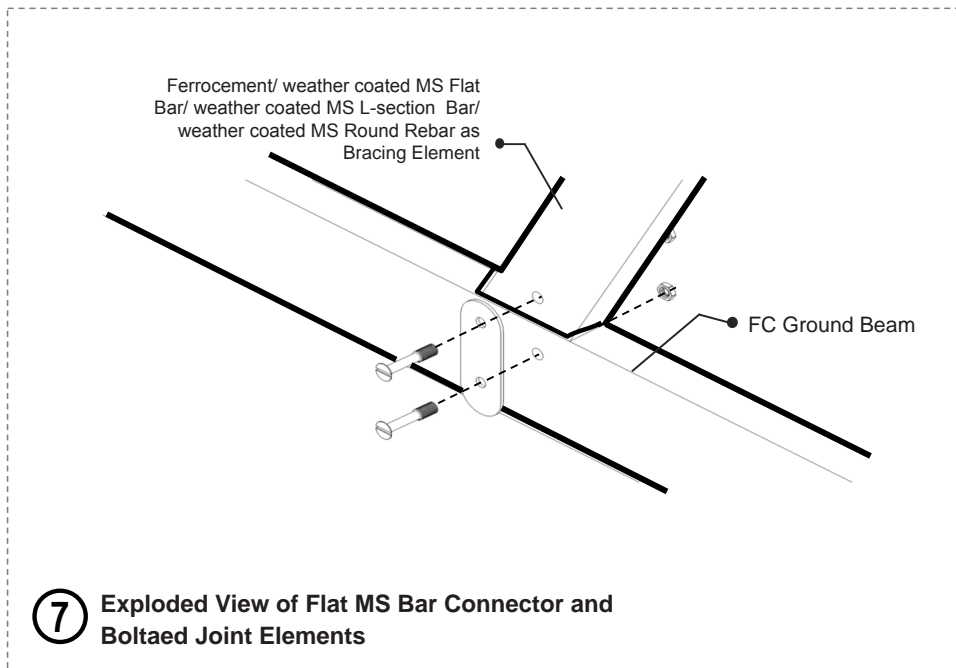

**(7) Exploded View of Flat MS Bar Connector and Bolted Joint Elements**

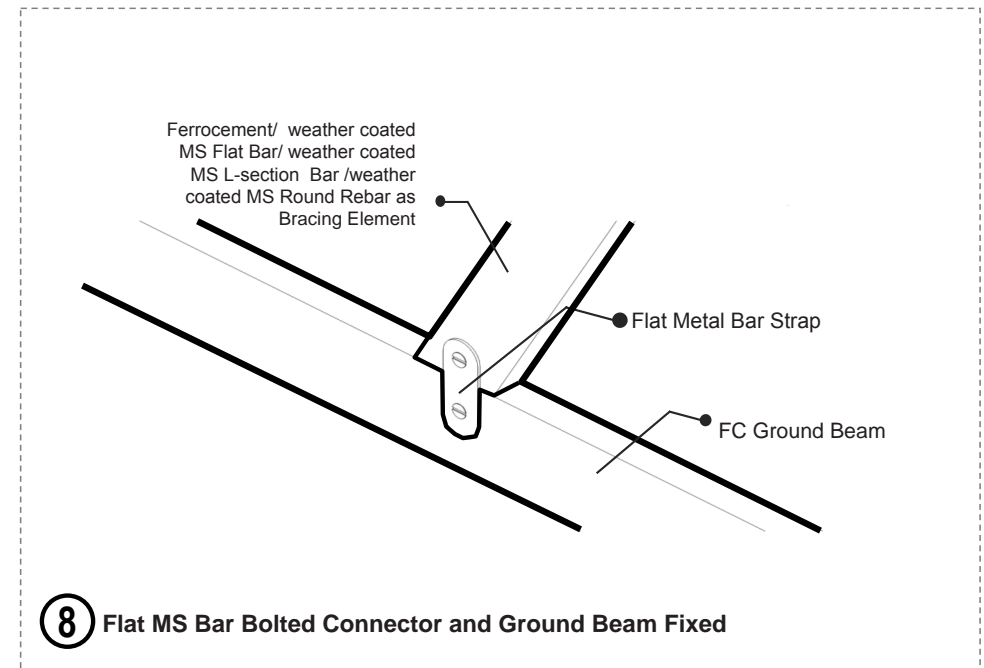

**(8) Flat MS Bar Bolted Connector and Ground Beam Fixed**

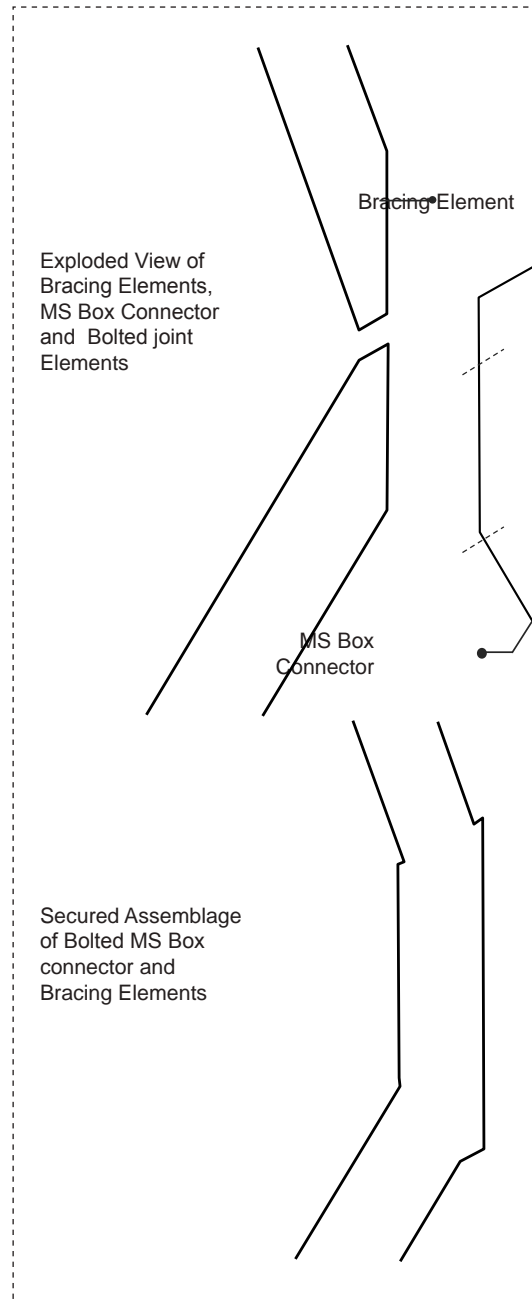
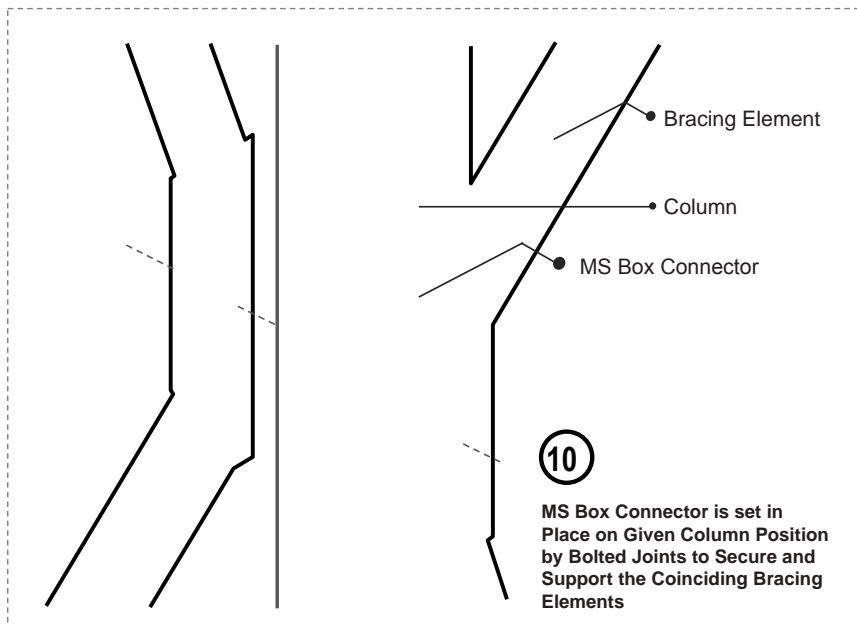
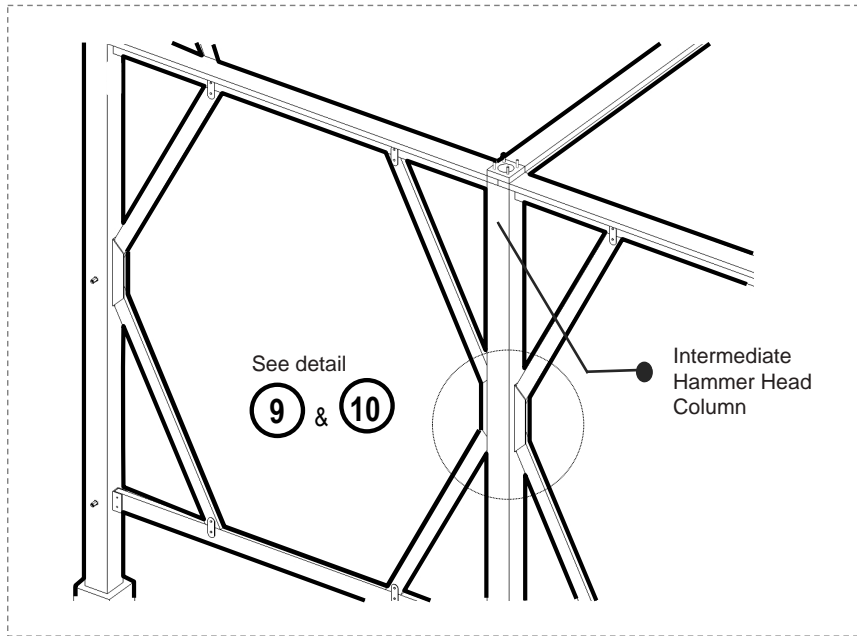

**9** + **10**

**Bracing Element and Column Joining Detail**

The complex connection between multiple bracing elements and the supporting column is secured by MS box connectors which are fixed by multiple bolted joints.



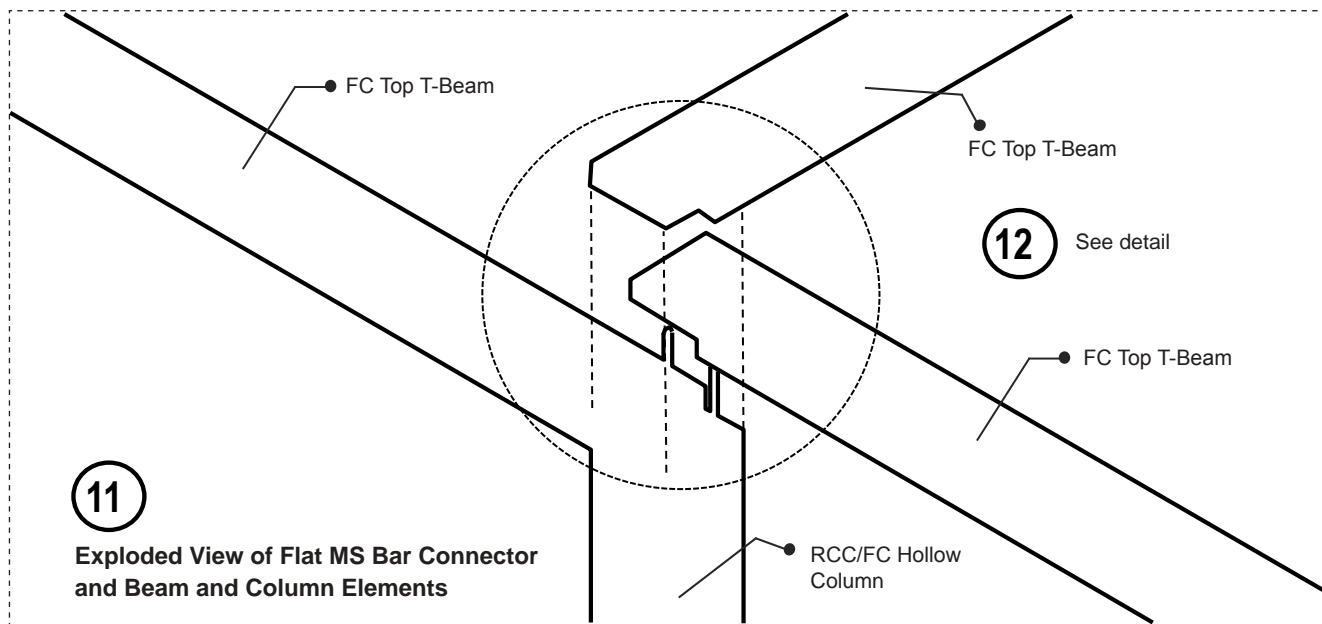

11

**Exploded View of Flat MS Bar Connector and Beam and Column Elements**

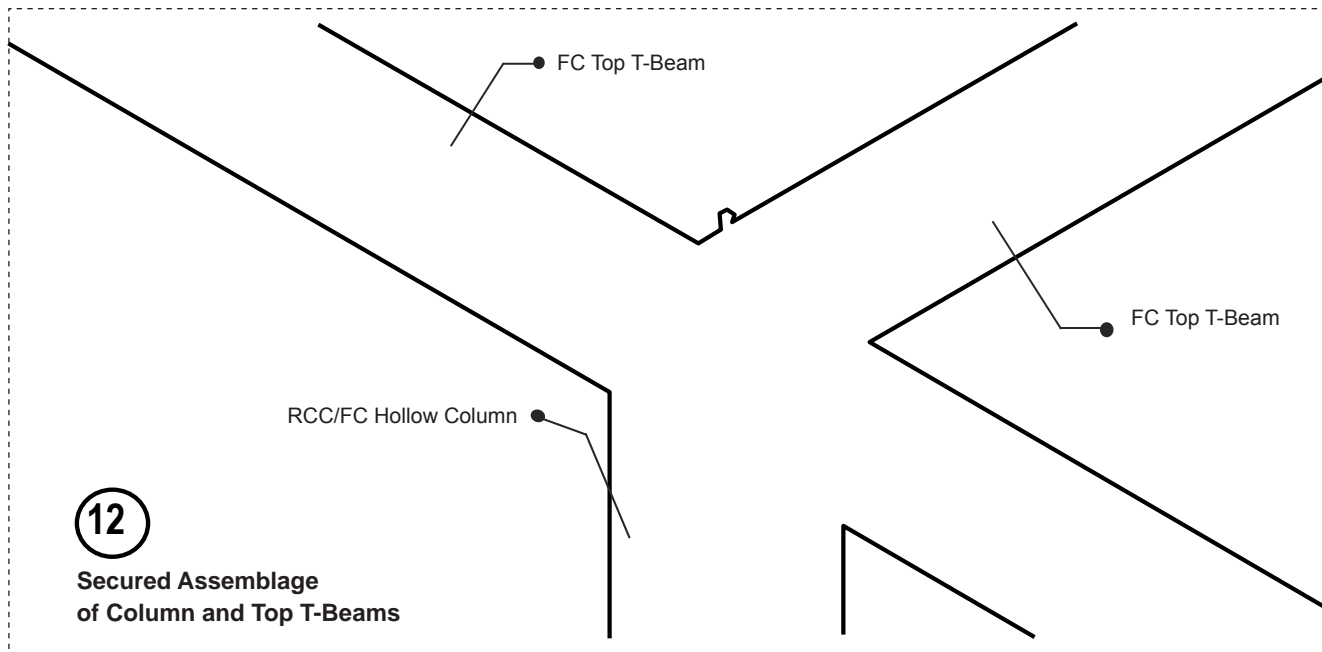

12

**Secured Assemblage of Column and Top T-Beams**

11 + 12

**Column and Top T-Beam Joint Detail**

T section top beams with their punctuated metal capped front nose are secured on supporting column by protruding MS rebar.

**13**+**14**

### FC Top T-Beam and Top Bracing Joint Detail

T section top beams with their punctuated metal capped front nose are secured on supporting column by protruding MS rebar.

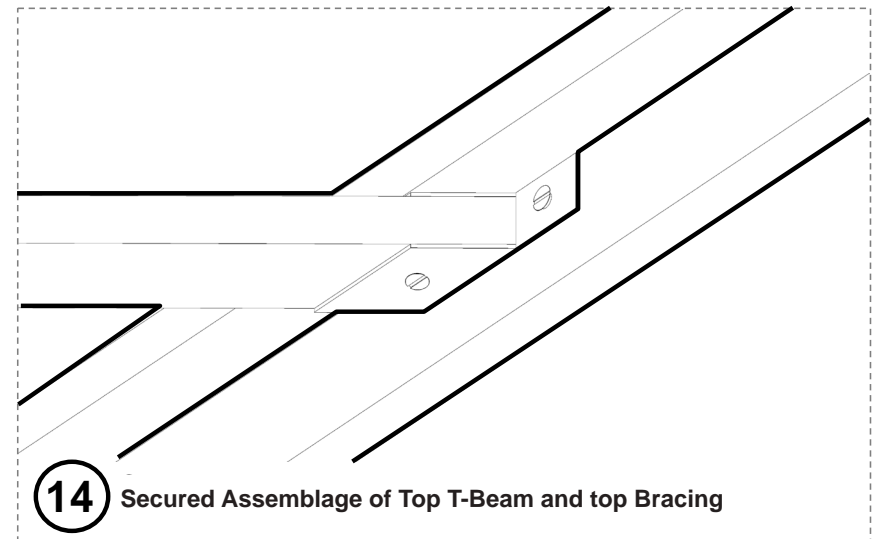
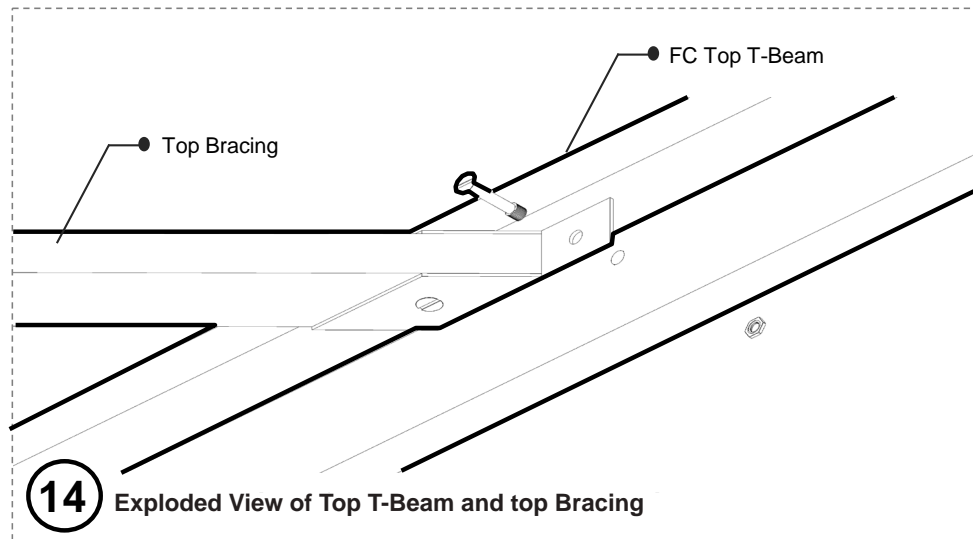
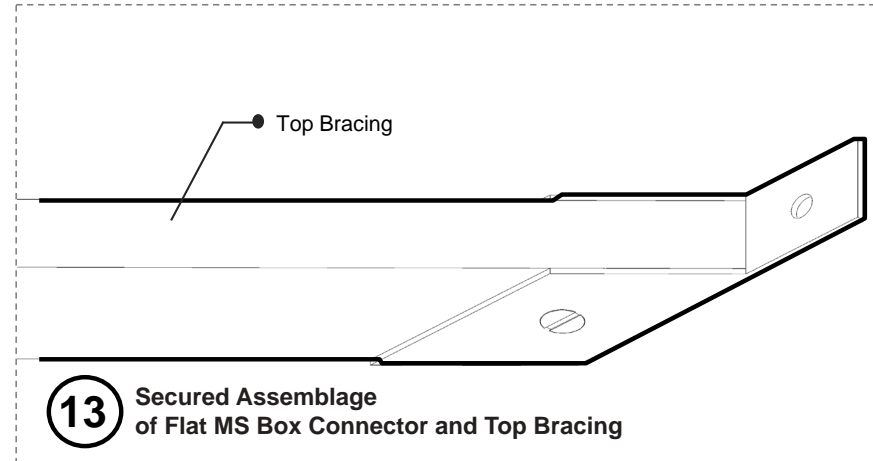
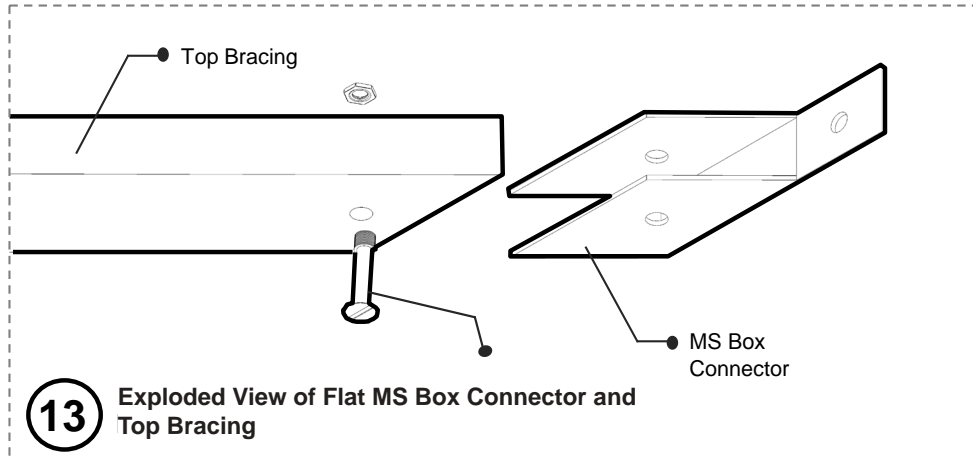

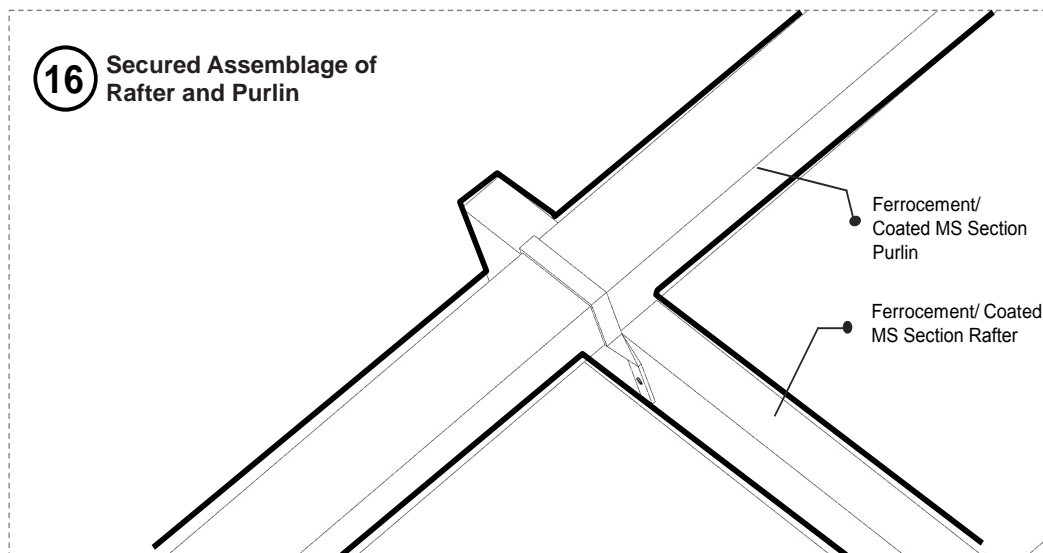
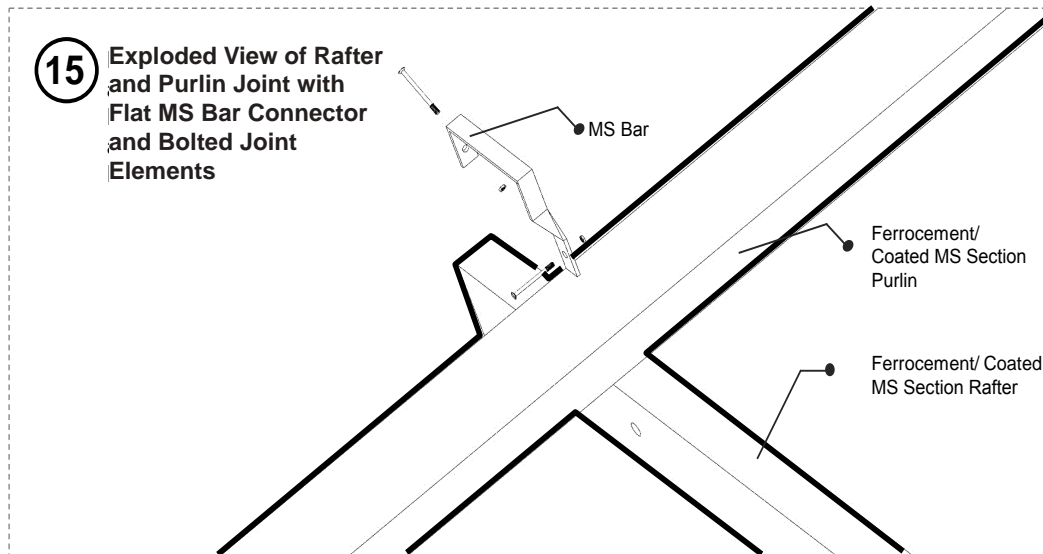

**15**+**16**

### Screw joint detail of Rafter and purlin

The connection between rafter and purlin is secured by MS bar connectors which are fixed by multiple bolted joints.

## JOINEY DETAILS FOR WEATHER COATED MS BRACING ELEMENTS

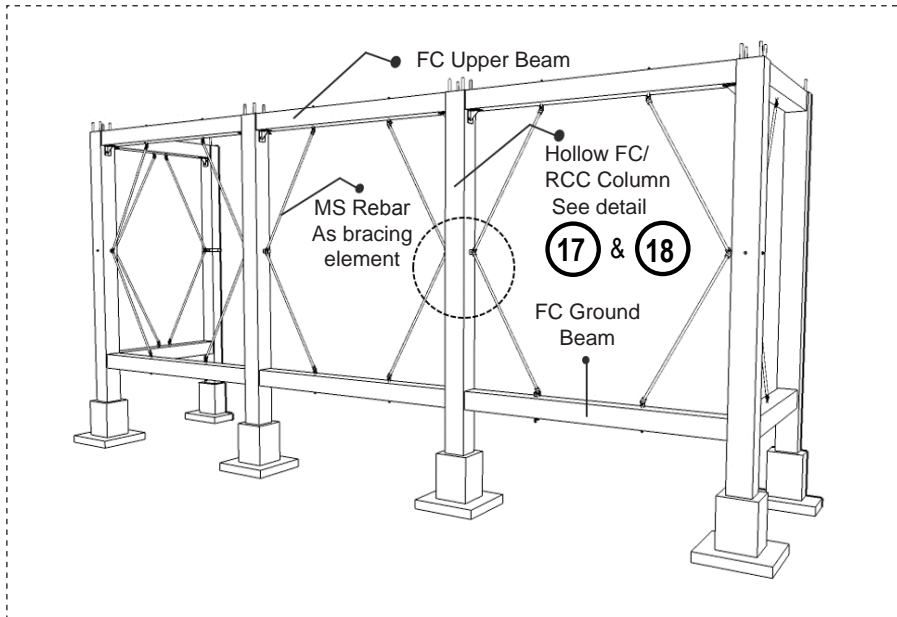

17 + 18

### MS Round Rebar Bracing Joint Detail at Intermediate Column with MS Bracket

The connection between MS rebar and column is secured by MS bracket which are fixed by bolted joints.

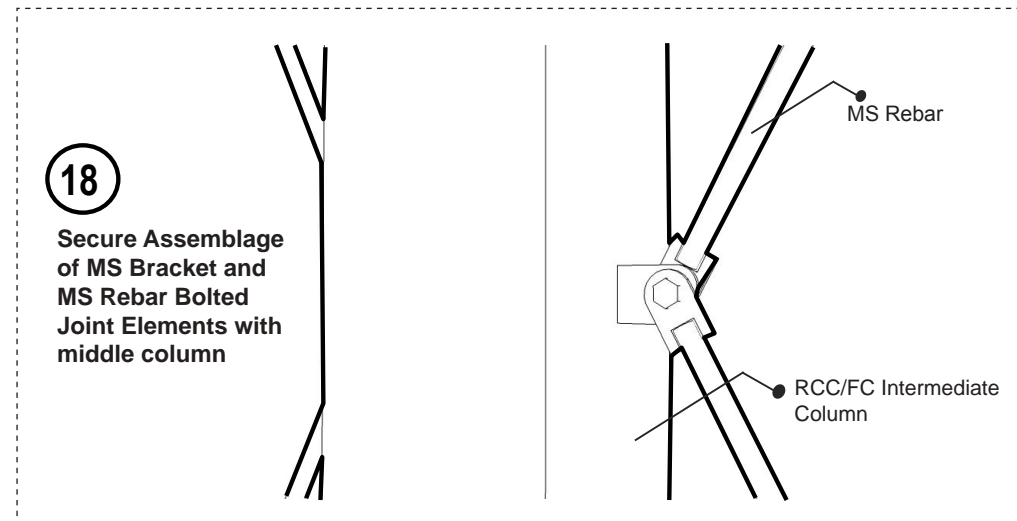
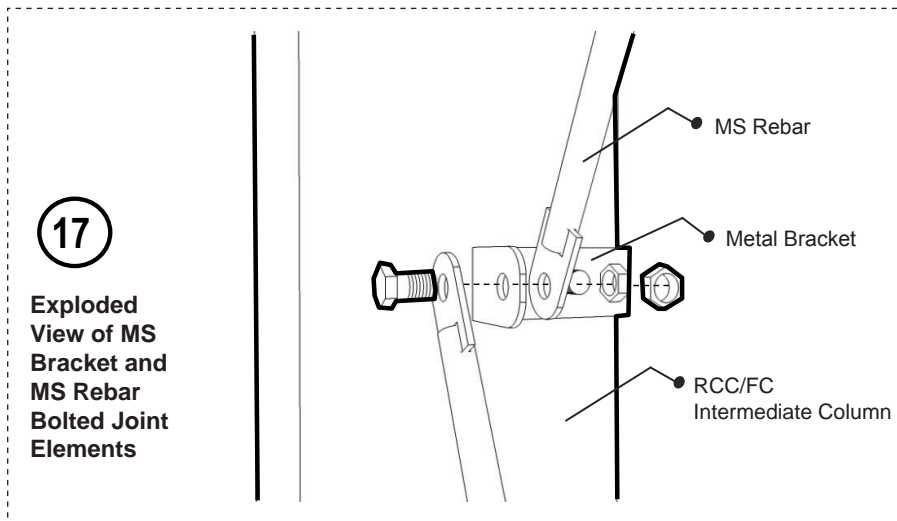

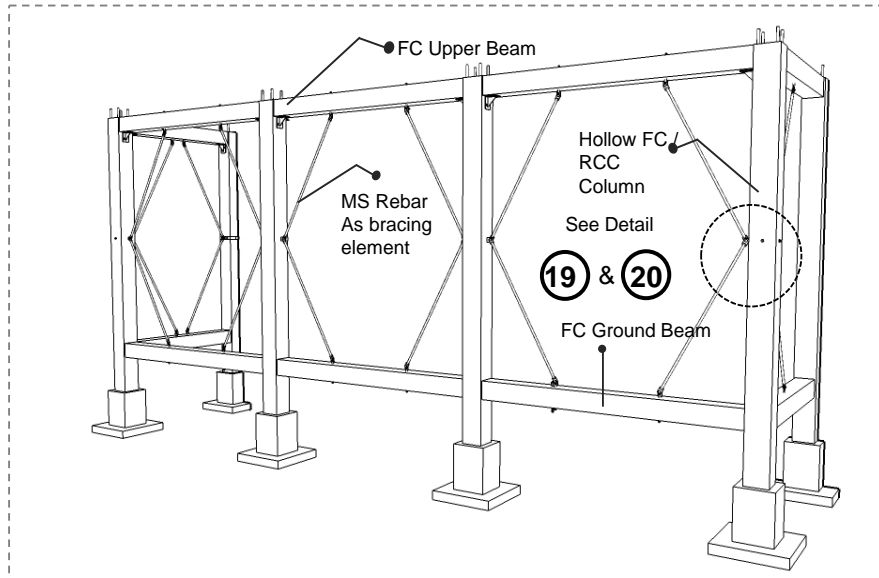

19 + 20

**MS Round Rebar Bracing Joint Detail at Corner Column with Connection Flanges**

The connection between MS rebar and column is secured by connection flanges which are fixed by bolted joints.

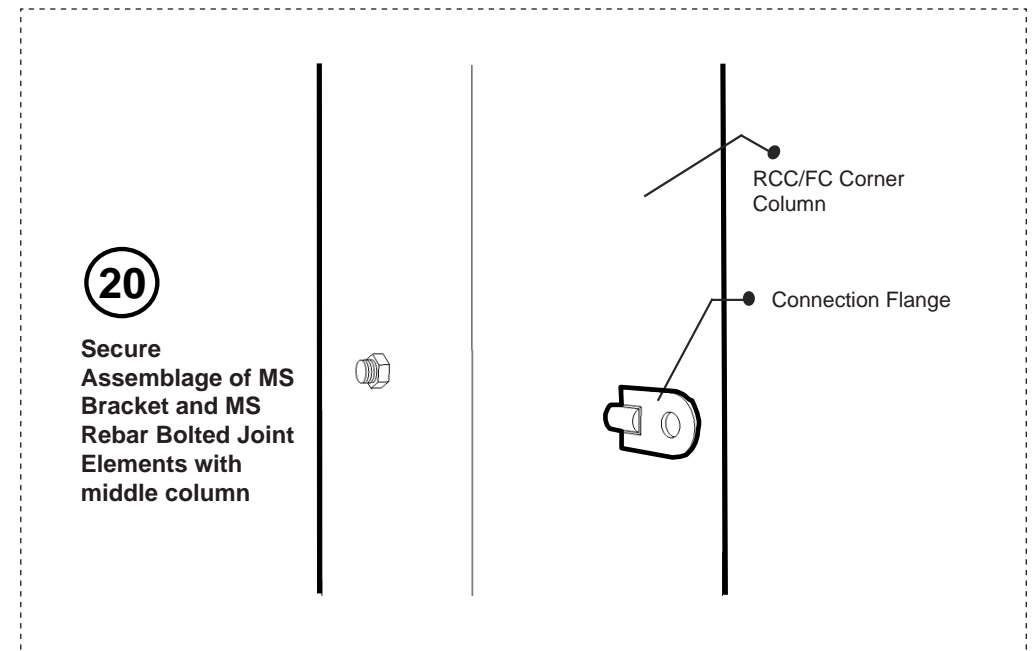
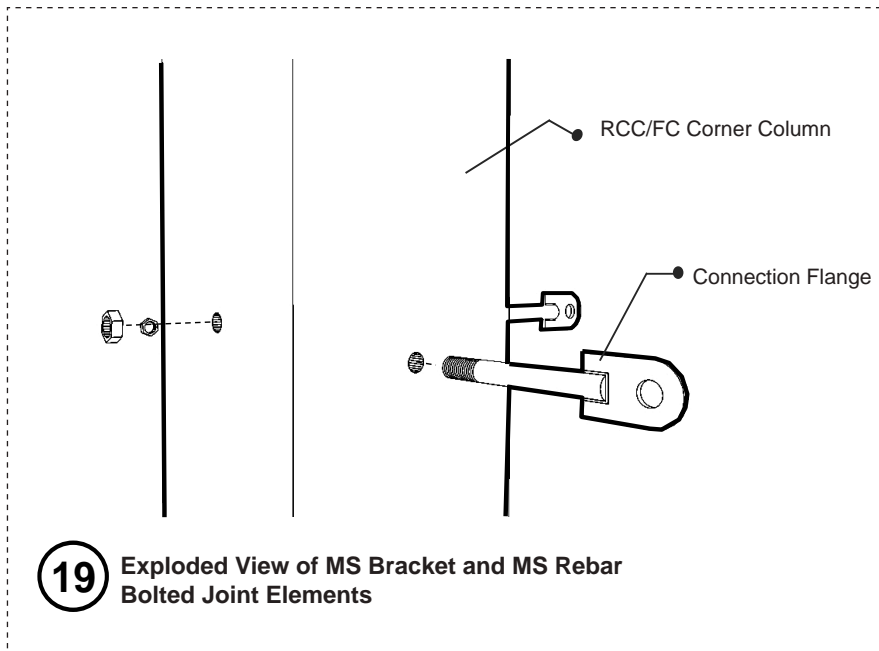



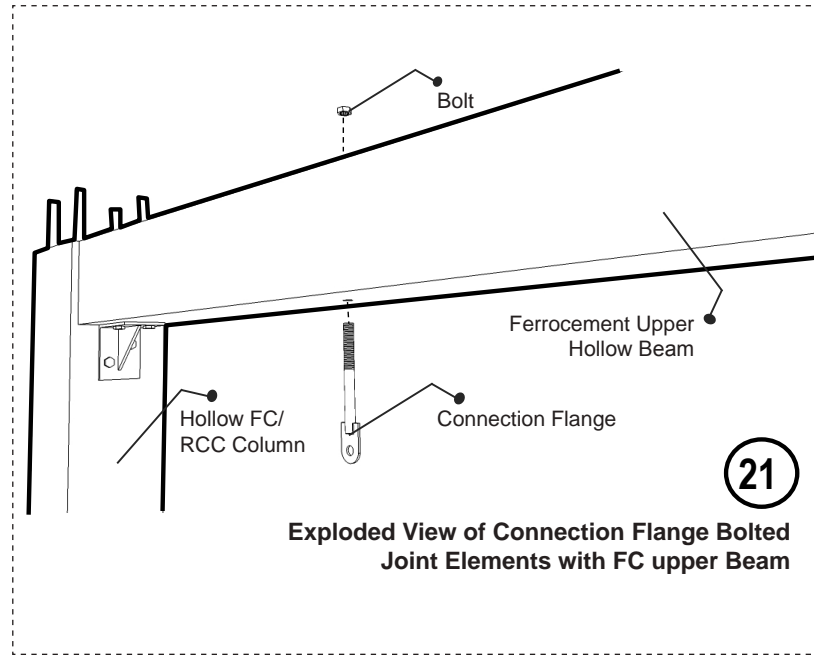
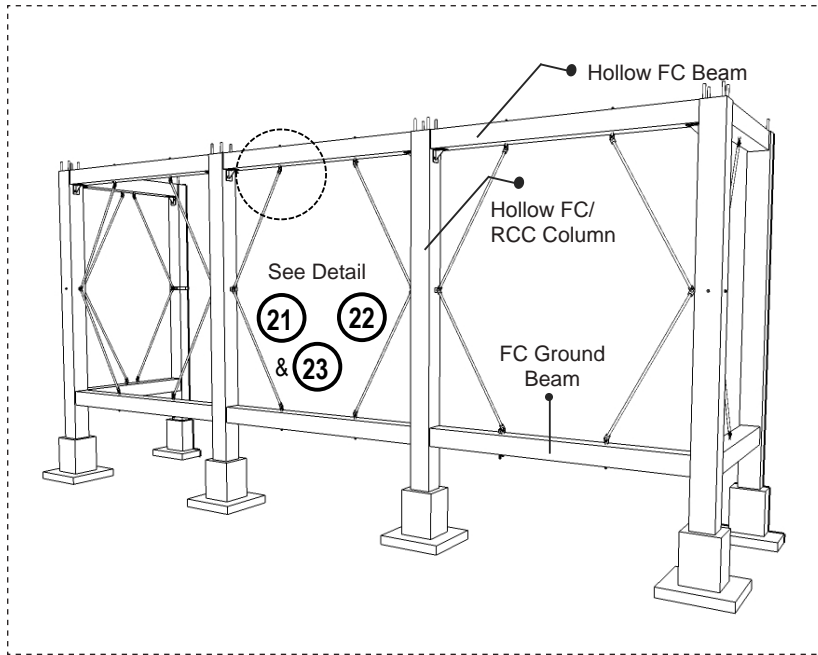

21 + 22 + 23

**MS Round Rebar Bracing and Connection Flange Joint Detail at FC Upper Beam**

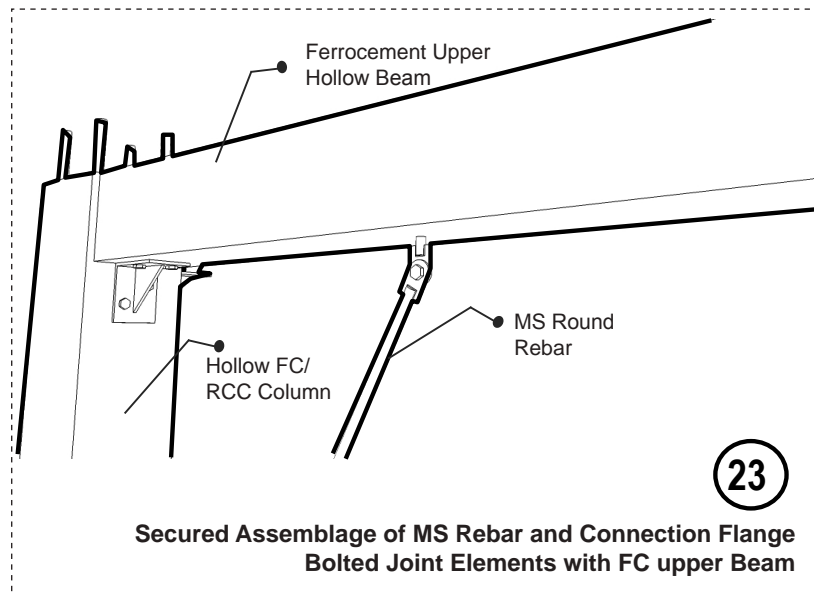
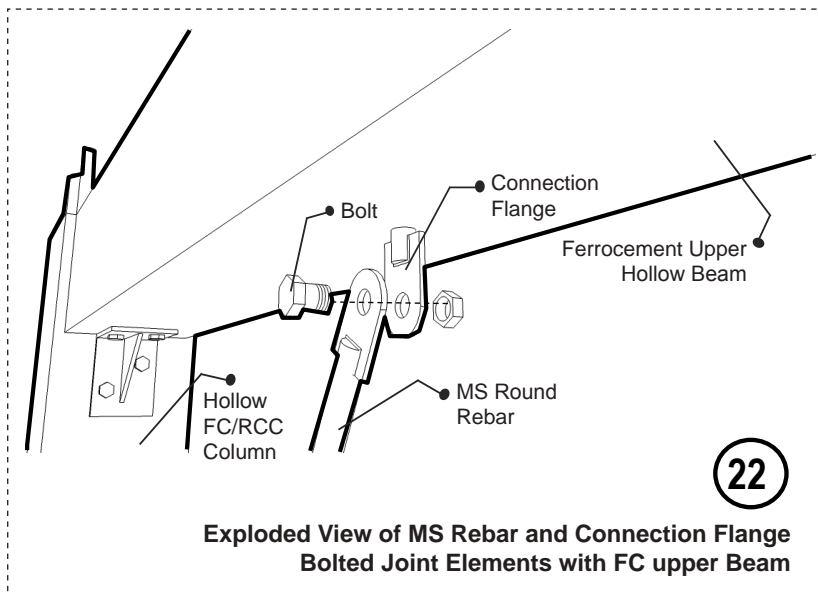

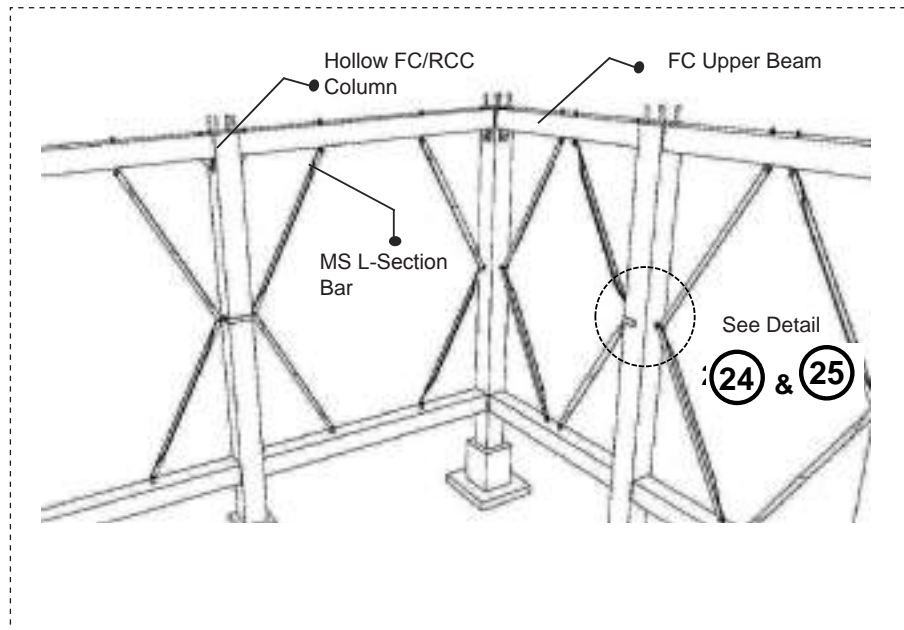

24 + 25

**MS L-Section Bar Bracing Joint Detail with Column**

The connection between MS L-Section Bar and column is secured by metal strap which are fixed by bolted joints.

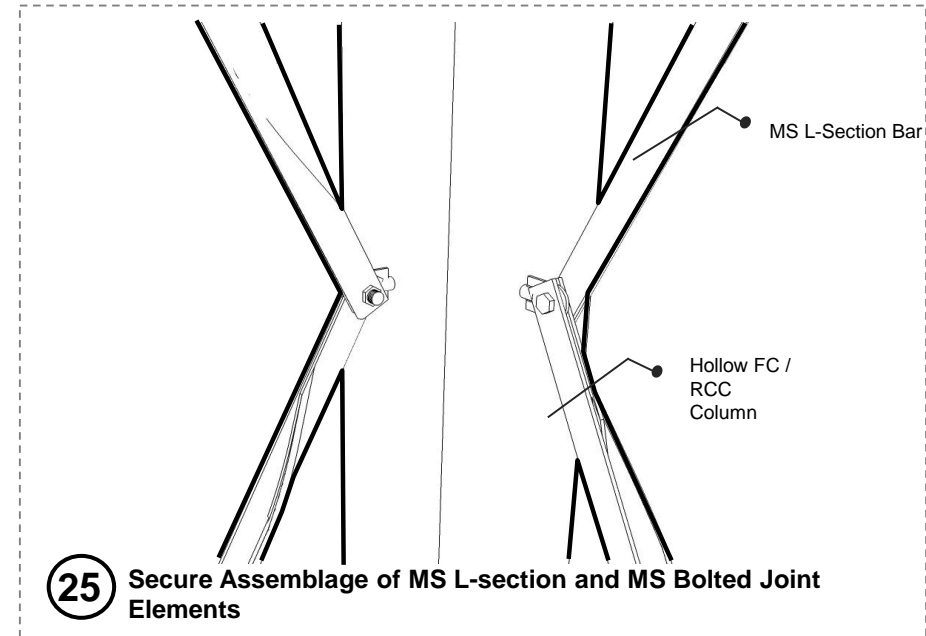
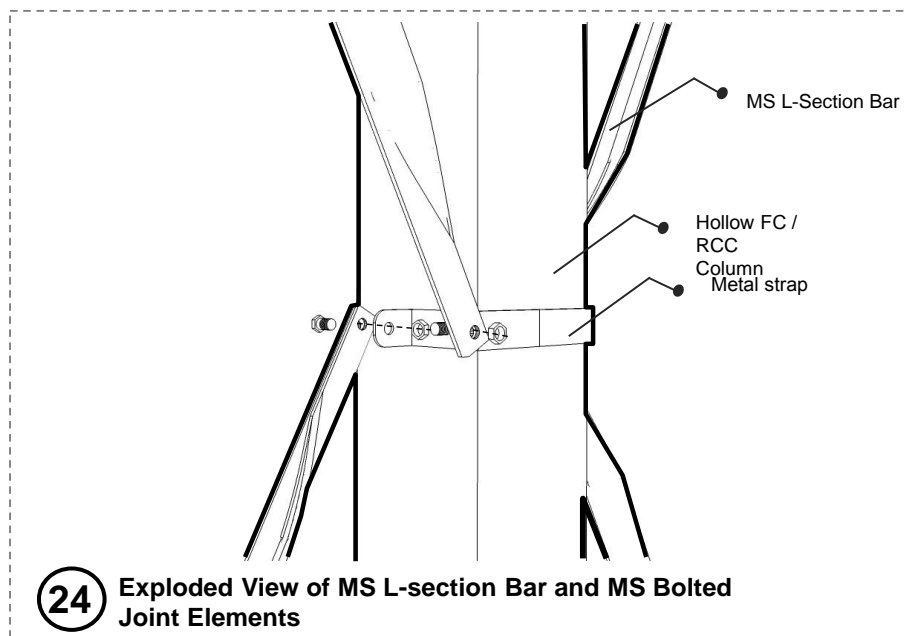

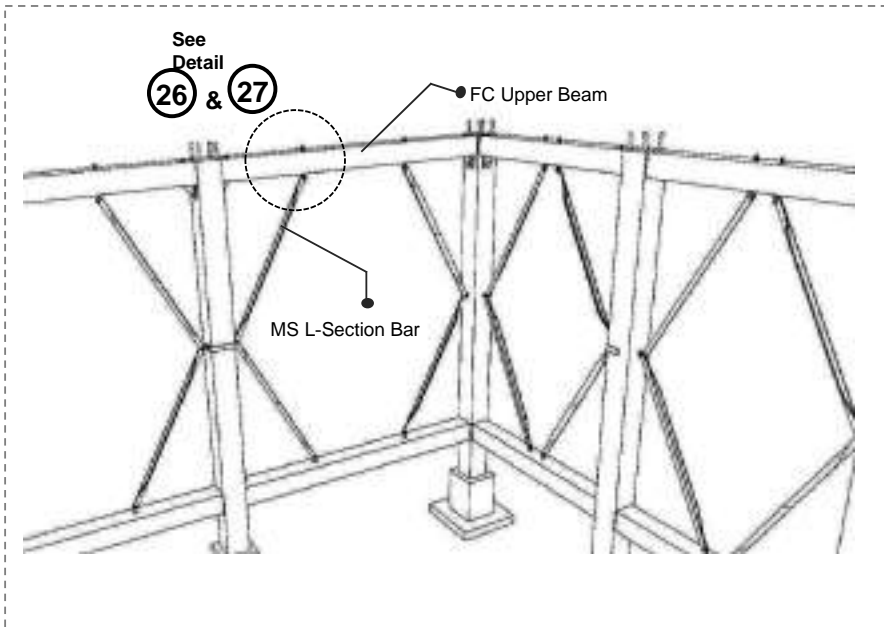

26+27

### MS L-Section Bar Bracing Joint Detail With FC Upper Beam

The connection between MS L-Section Bar and beam is secured by connection flanges which are fixed by bolted joints.

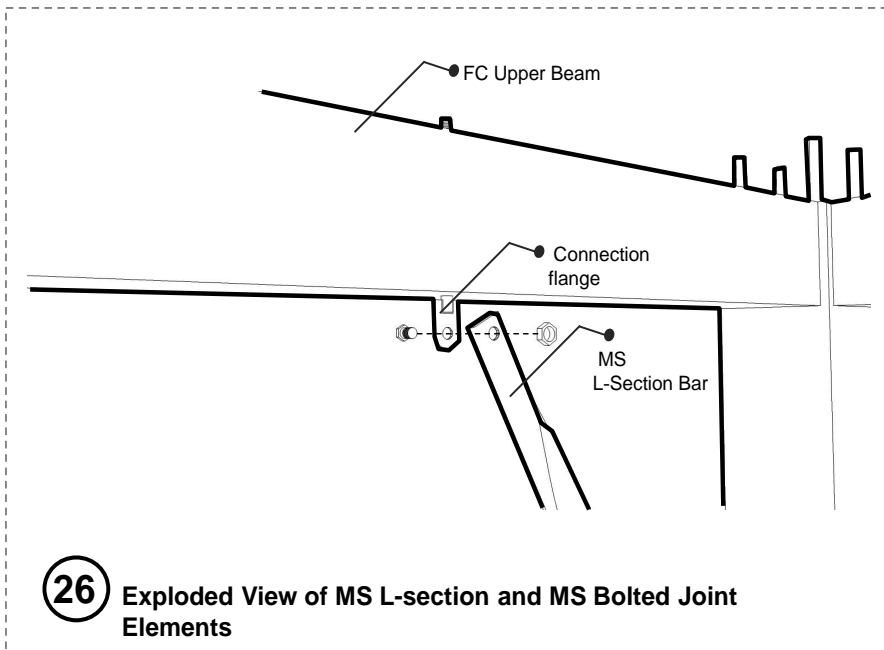

**26** Exploded View of MS L-section and MS Bolted Joint Elements

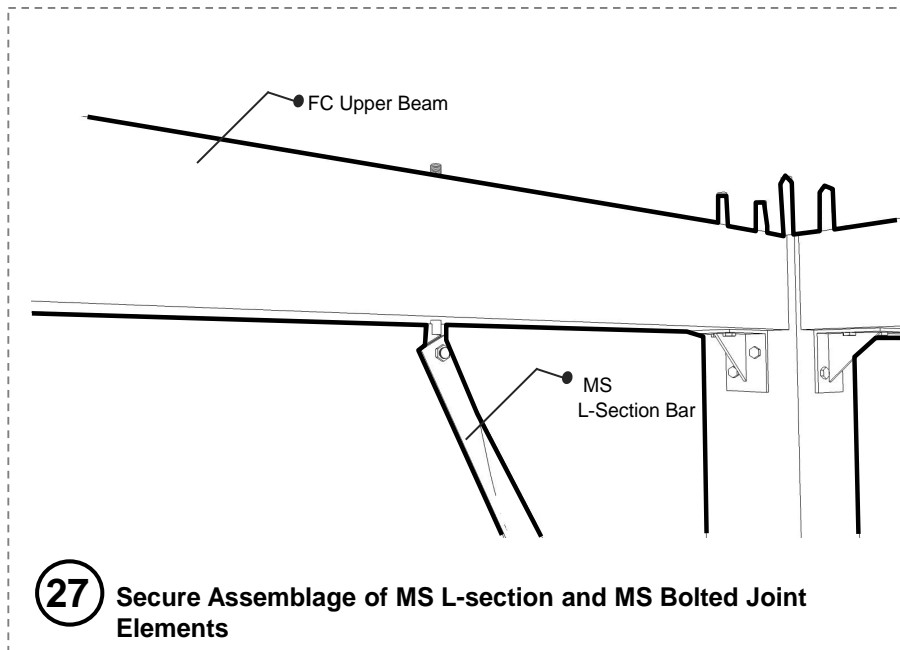

**27** Secure Assemblage of MS L-section and MS Bolted Joint Elements

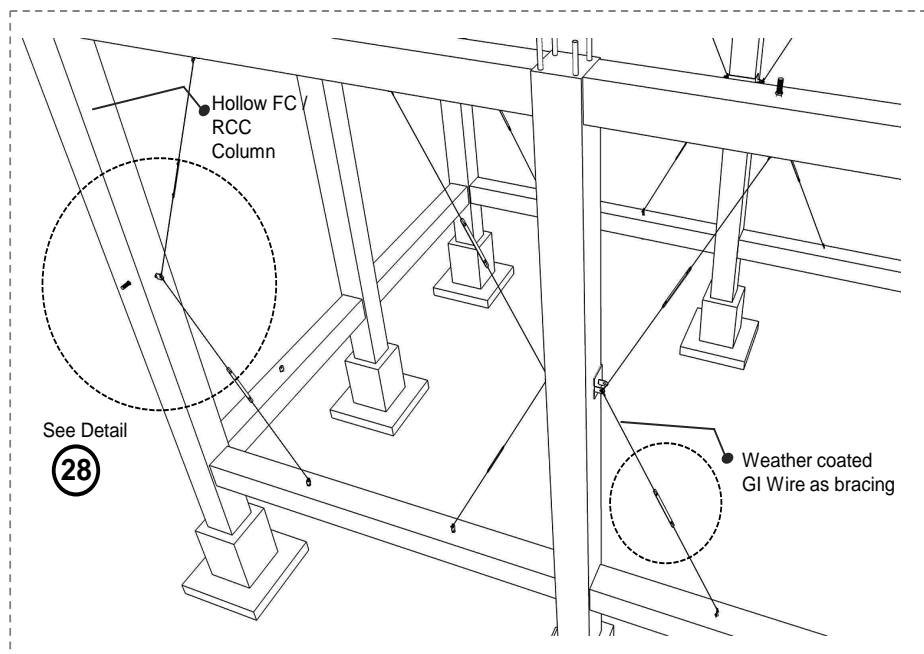

28+29

### Weather coated GI Wire Bracing Joint Detail with Column

The connection between coated GI wire and column is secured by MS connection flange which are fixed by bolted joints.

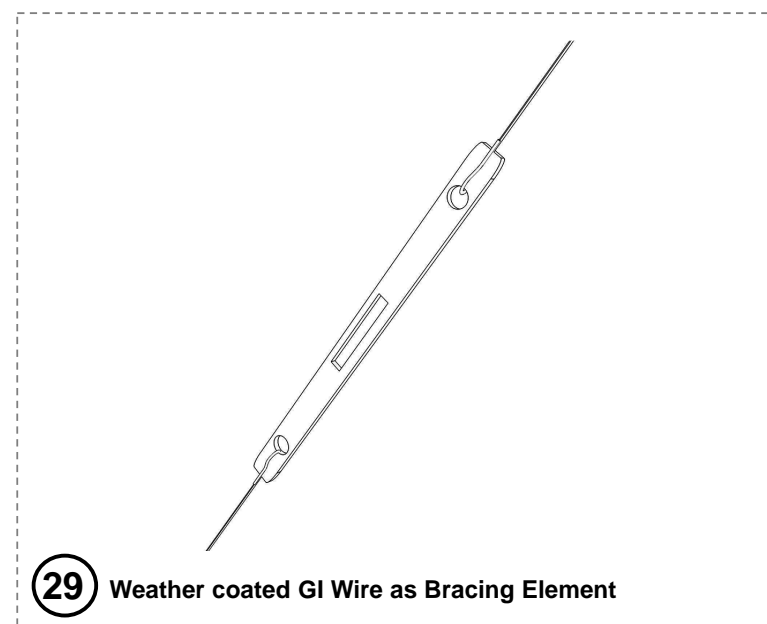
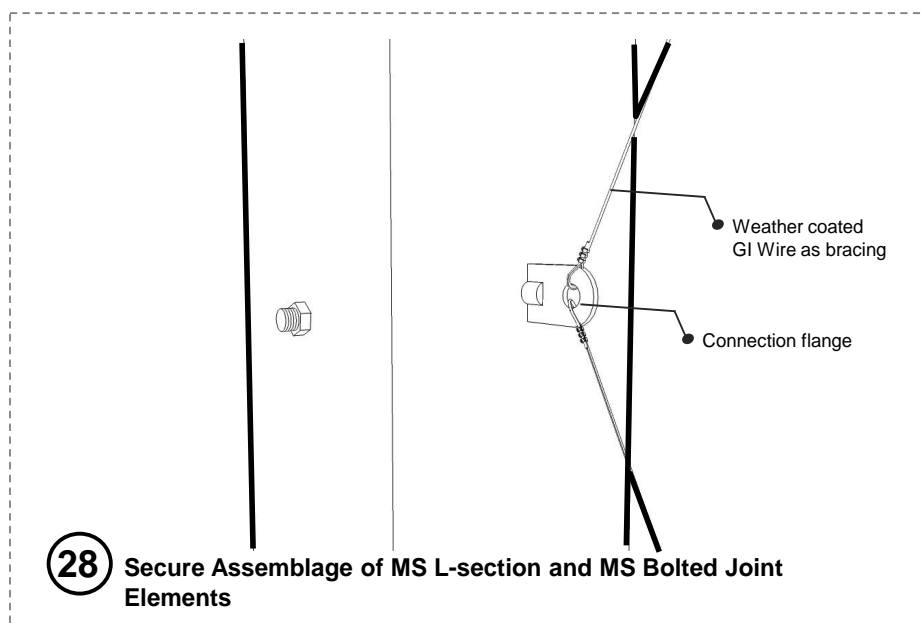

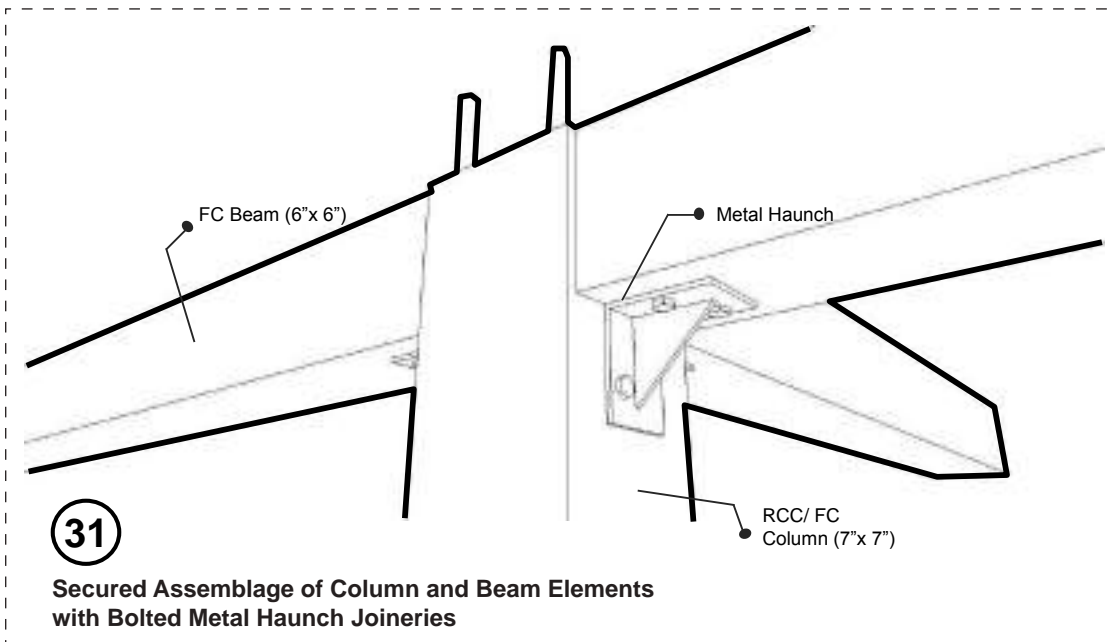
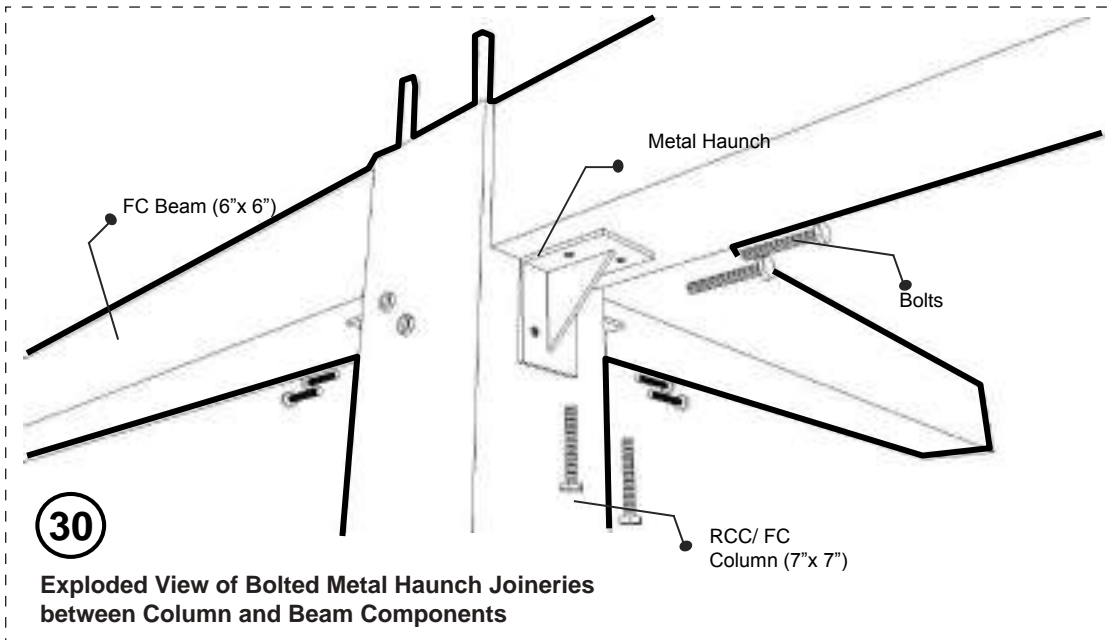

**30+31**

### Column and Beam Joint with Metal Haunch

The connection between RCC/FC hollow column and Fc hollow beam is Secured by metal haunches with bolted joints.



### 2.6.1.5 Engineering Drawings

#### Structural Details Model 1 Arrangement 1

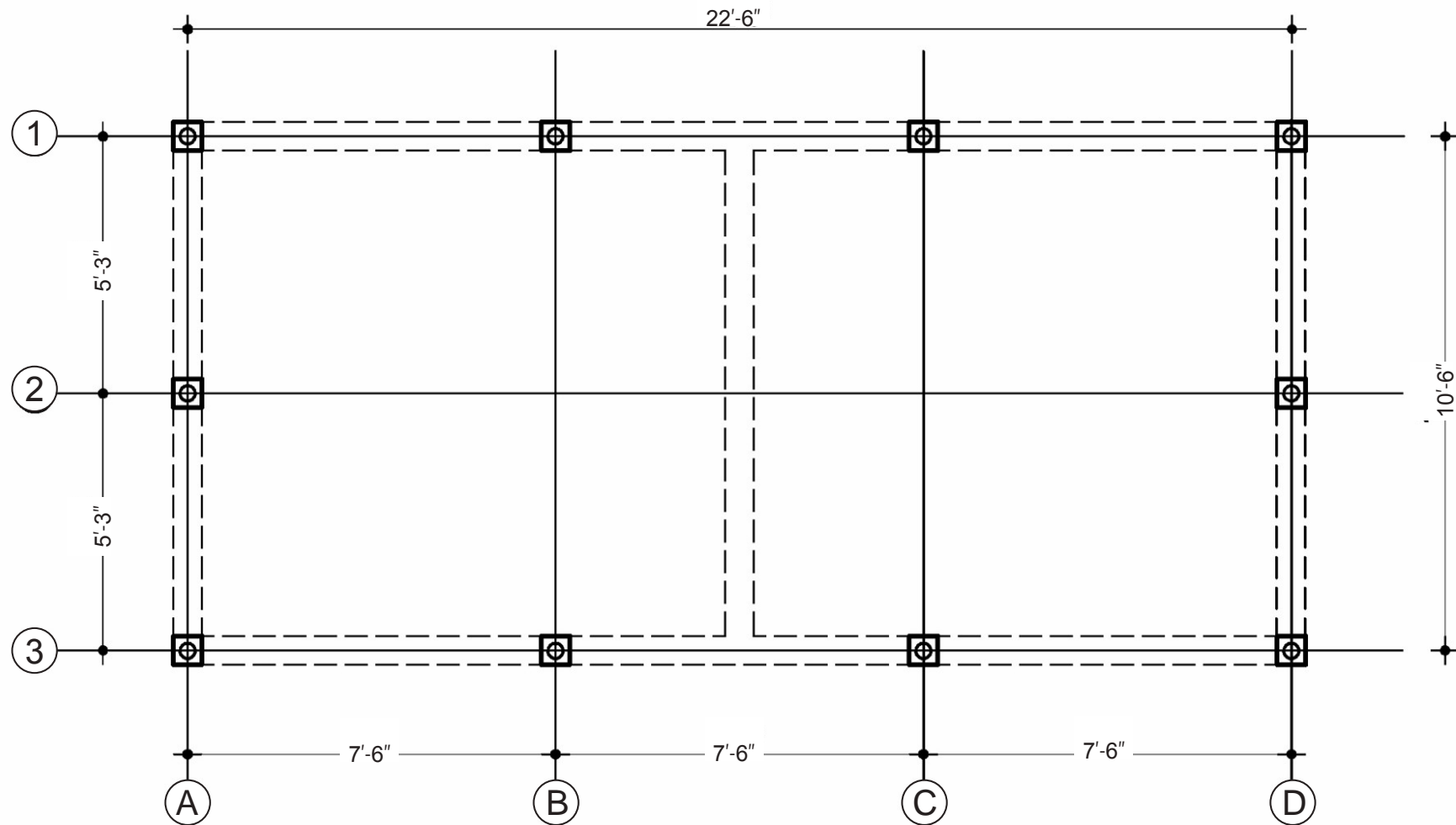

Beam-Column layout

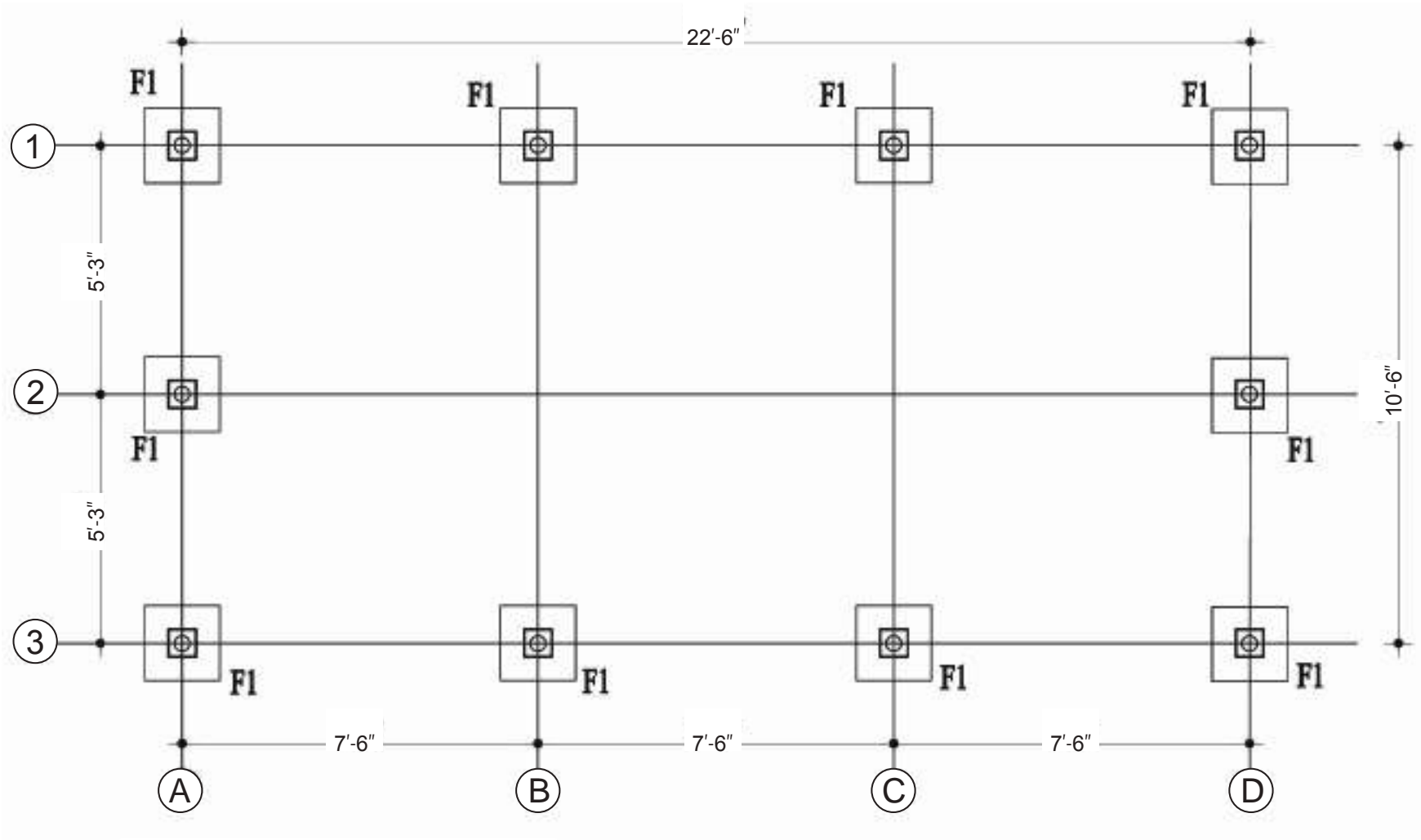

Foundation layout

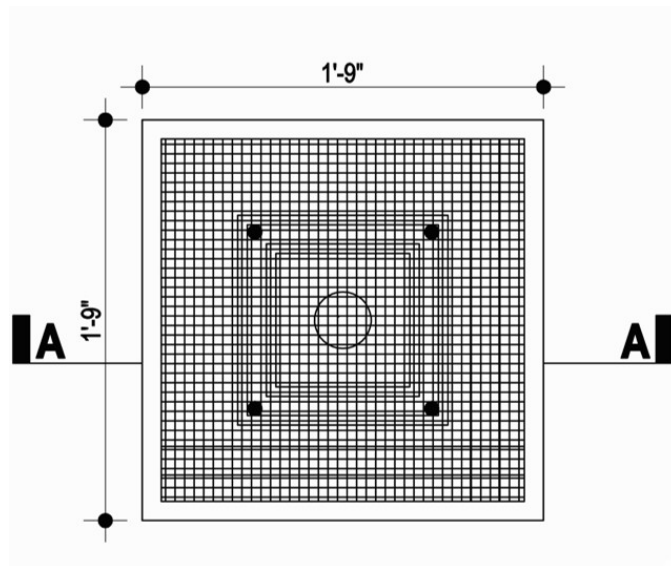

Plan of F.C pocket footing F1

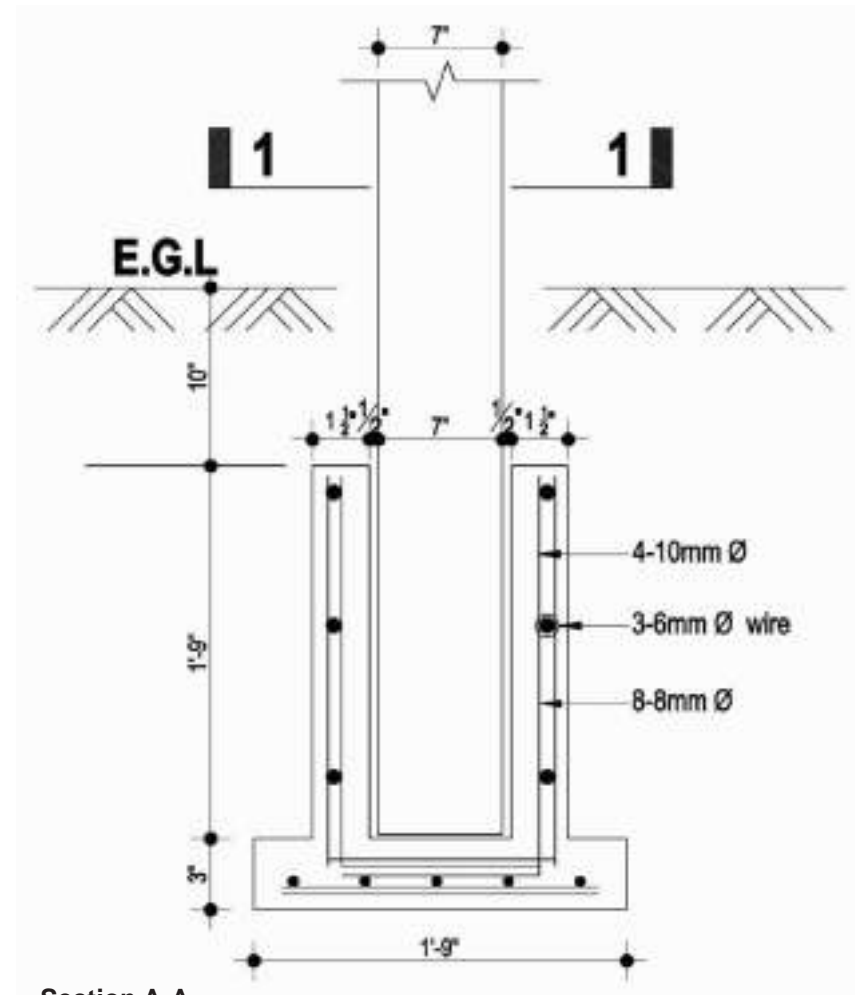

Section A-A

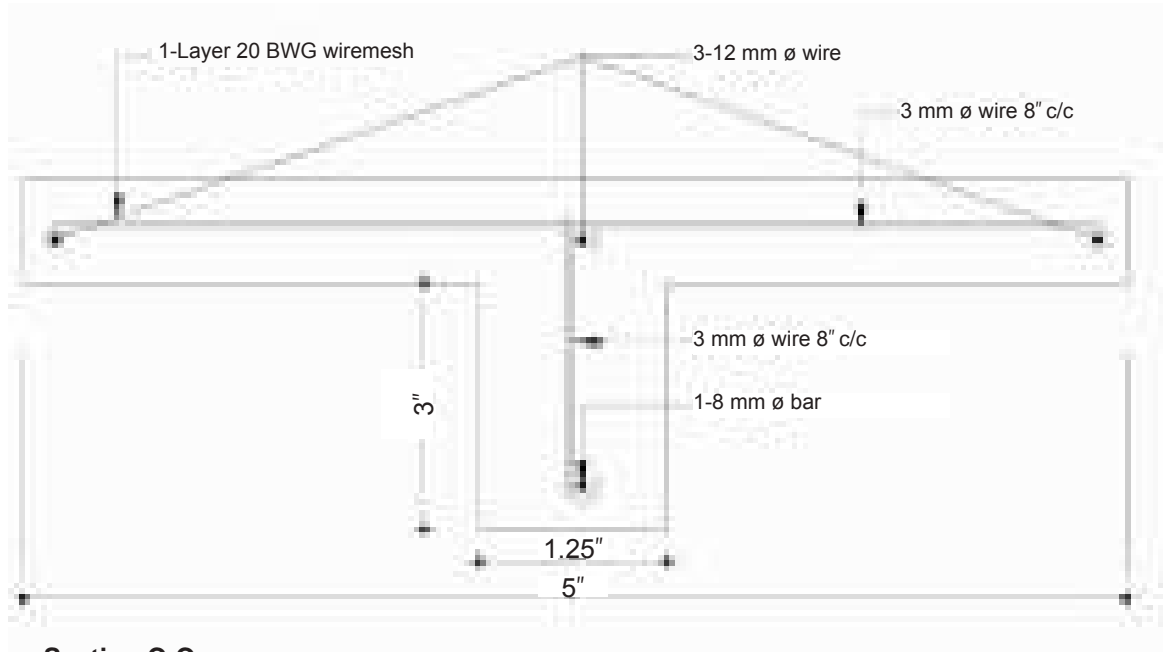

Section C-C

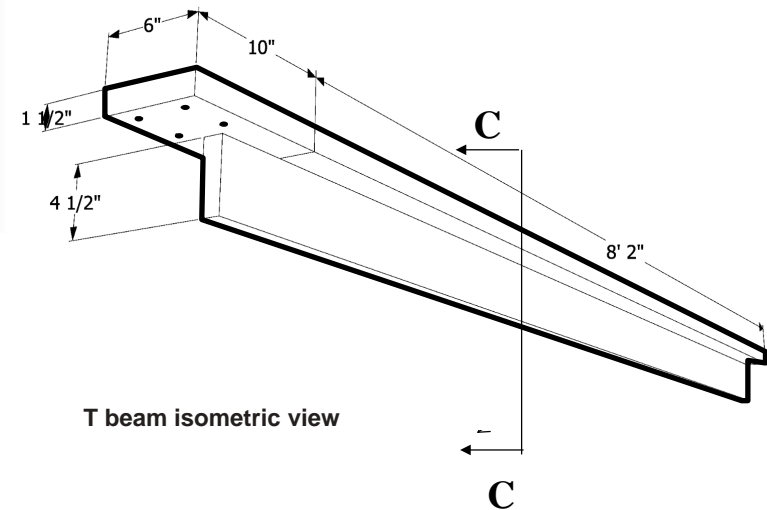
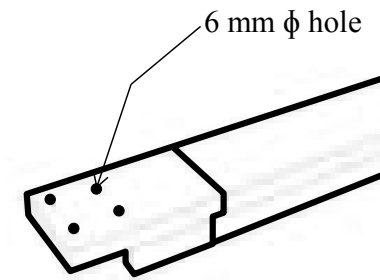

T beam isometric view

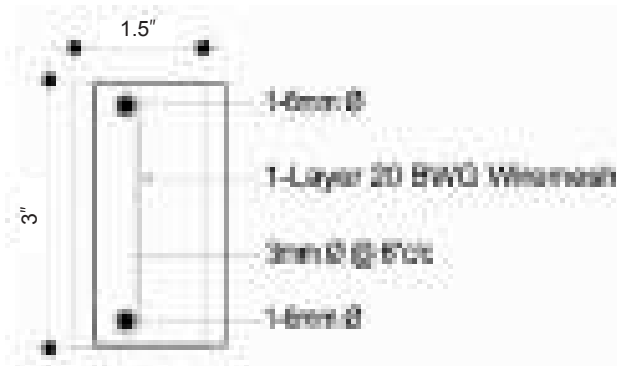
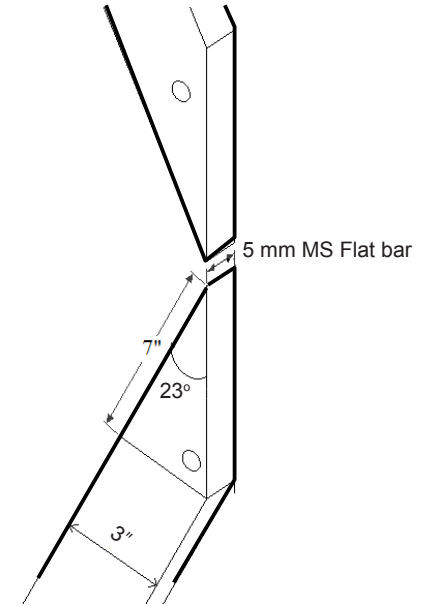
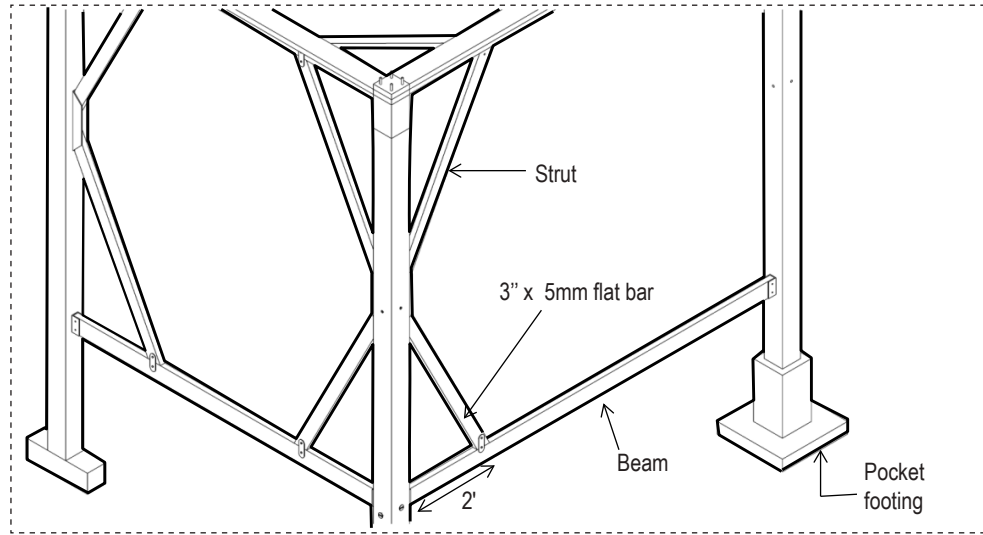

Section of Strut/Tie

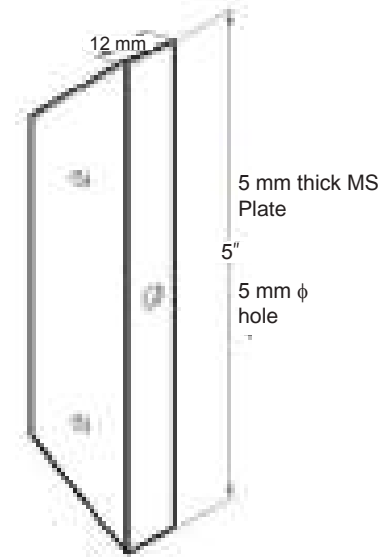



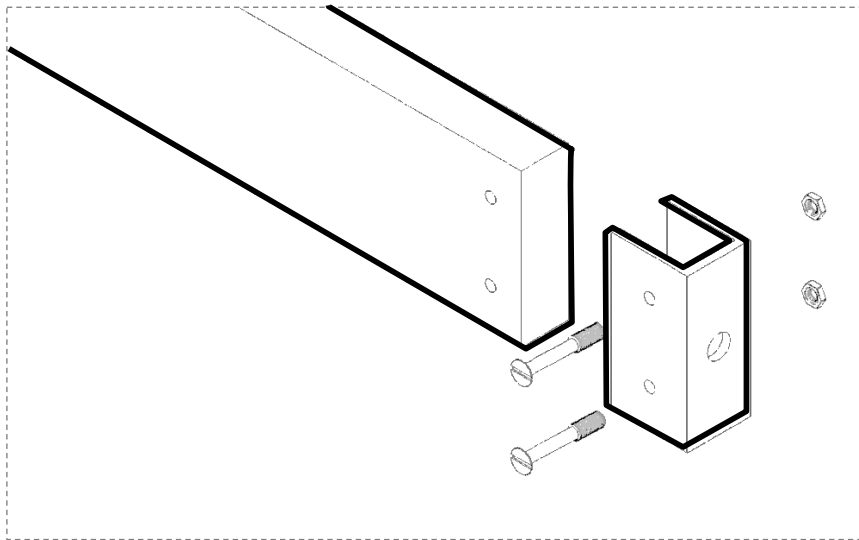

Screw joint details

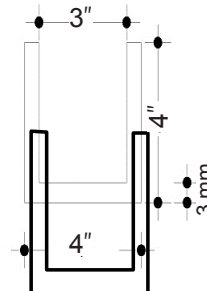
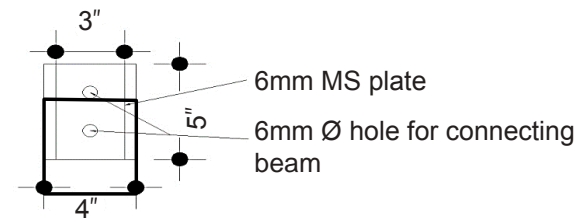
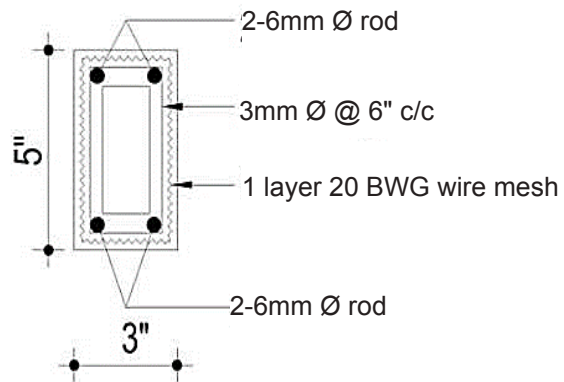
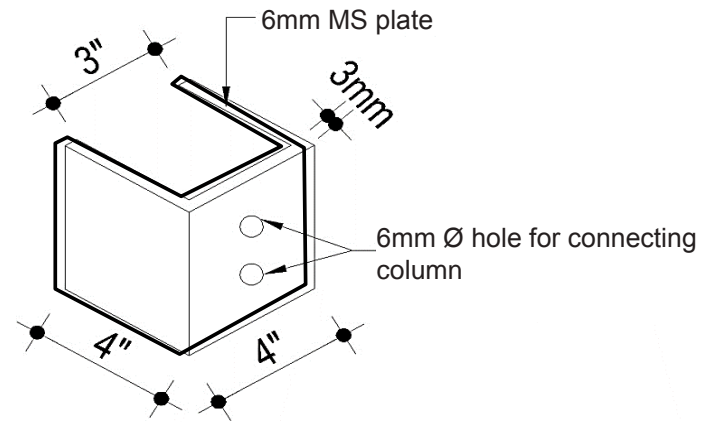

### SCREW JOINT DETAIL OF CONNECTING TOP BEAM AND BRACING JOINT

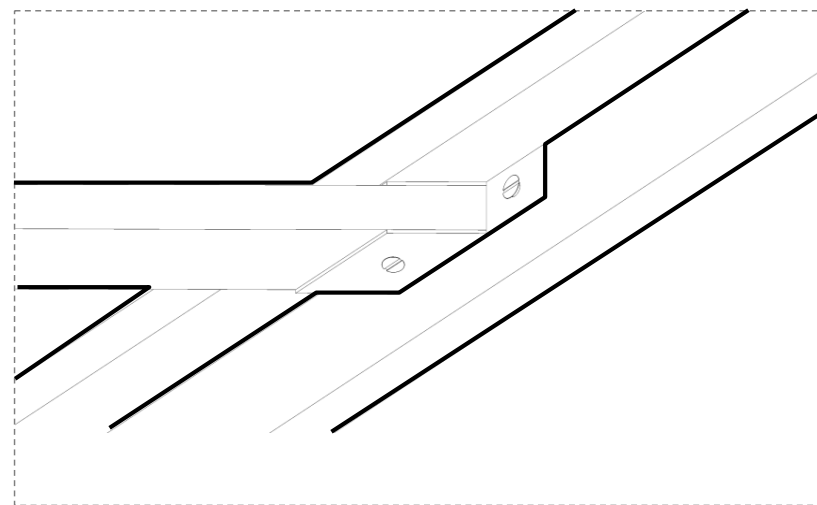
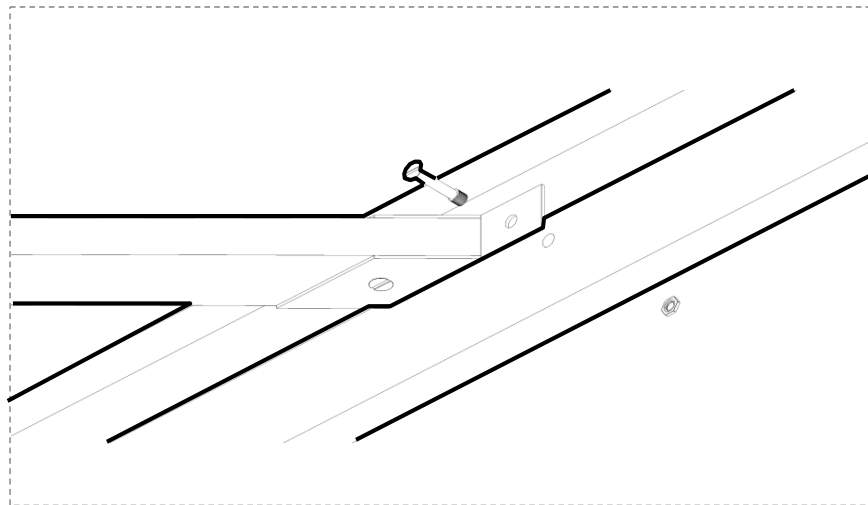
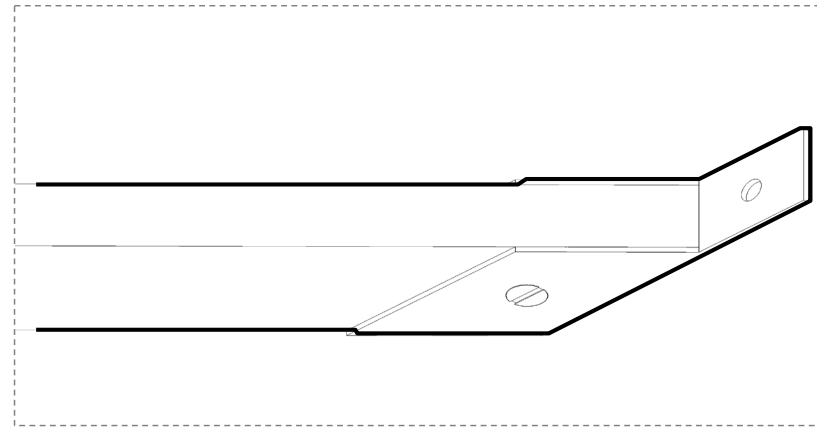
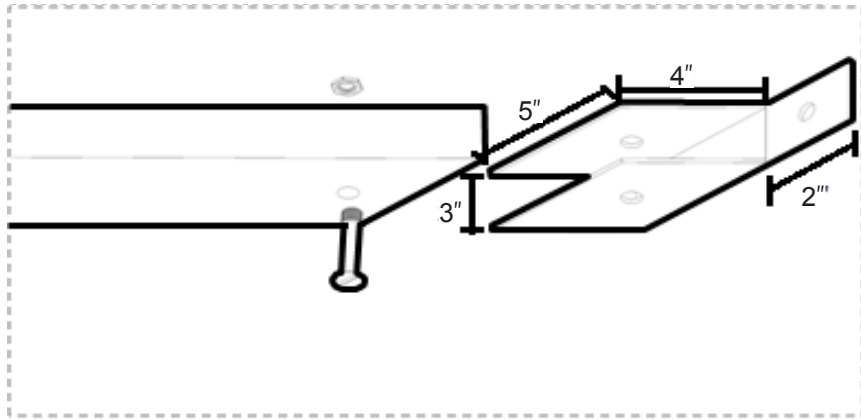

## 2.6.2 Load Bearing Structure

This two room house of load bearing masonry work has multiple flexibilities in terms of internal spatial division as per inhabitant's requirement.

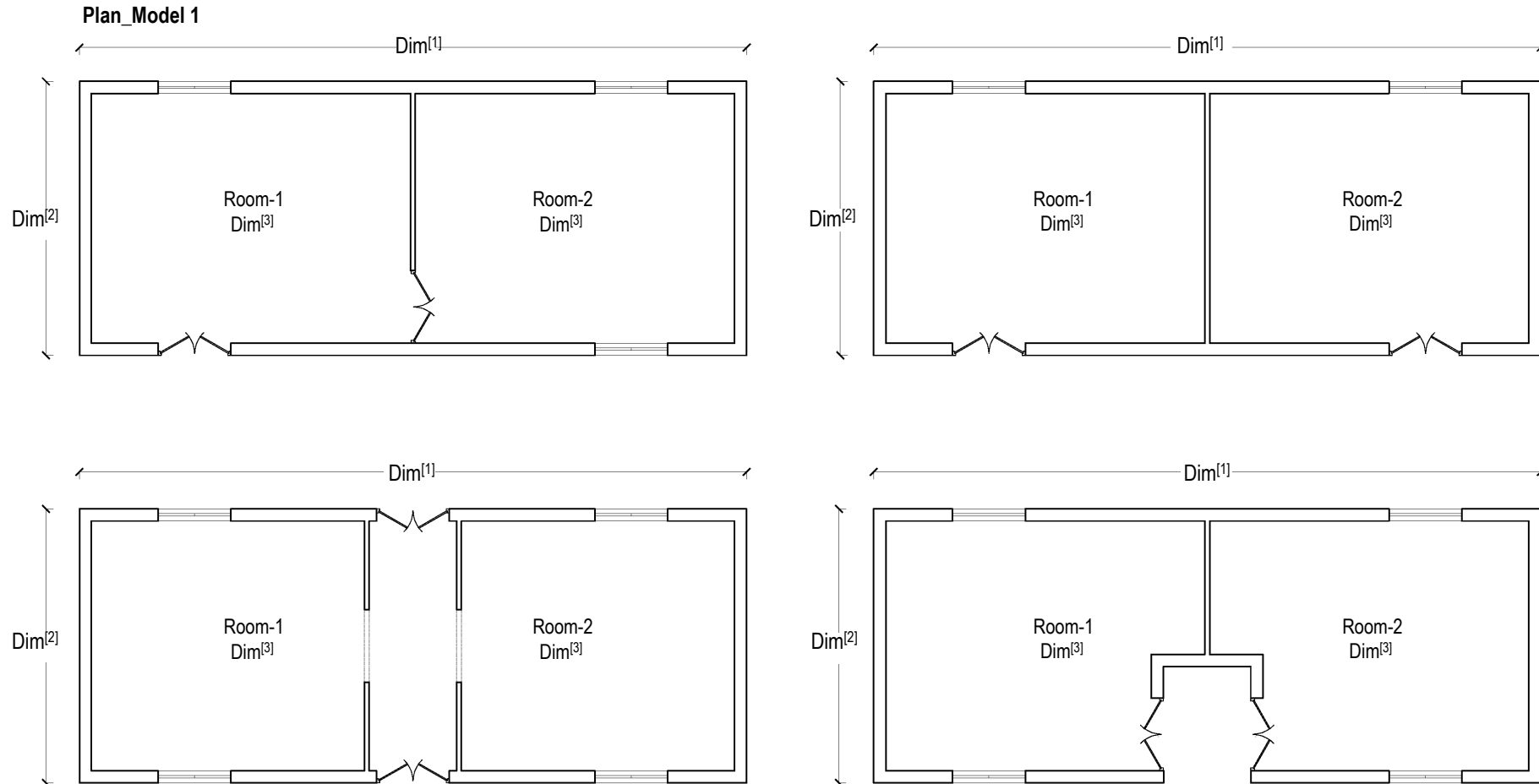

Dim<sup>[1]</sup> Dimension to be adjusted with available building block module and available local measuring unit ( e.g.1 haat= 1'6" ) but should not be less than 21'-0"

Dim<sup>[2]</sup> Dimension to be adjusted with available building block module and available local measuring unit but should not be less than 9'-6"

Dim<sup>[3]</sup> Dimension to be adjusted maintaining standards and local practice

### SECTION OF TWO LAYER THICK LOAD BEARING STRUCTURE

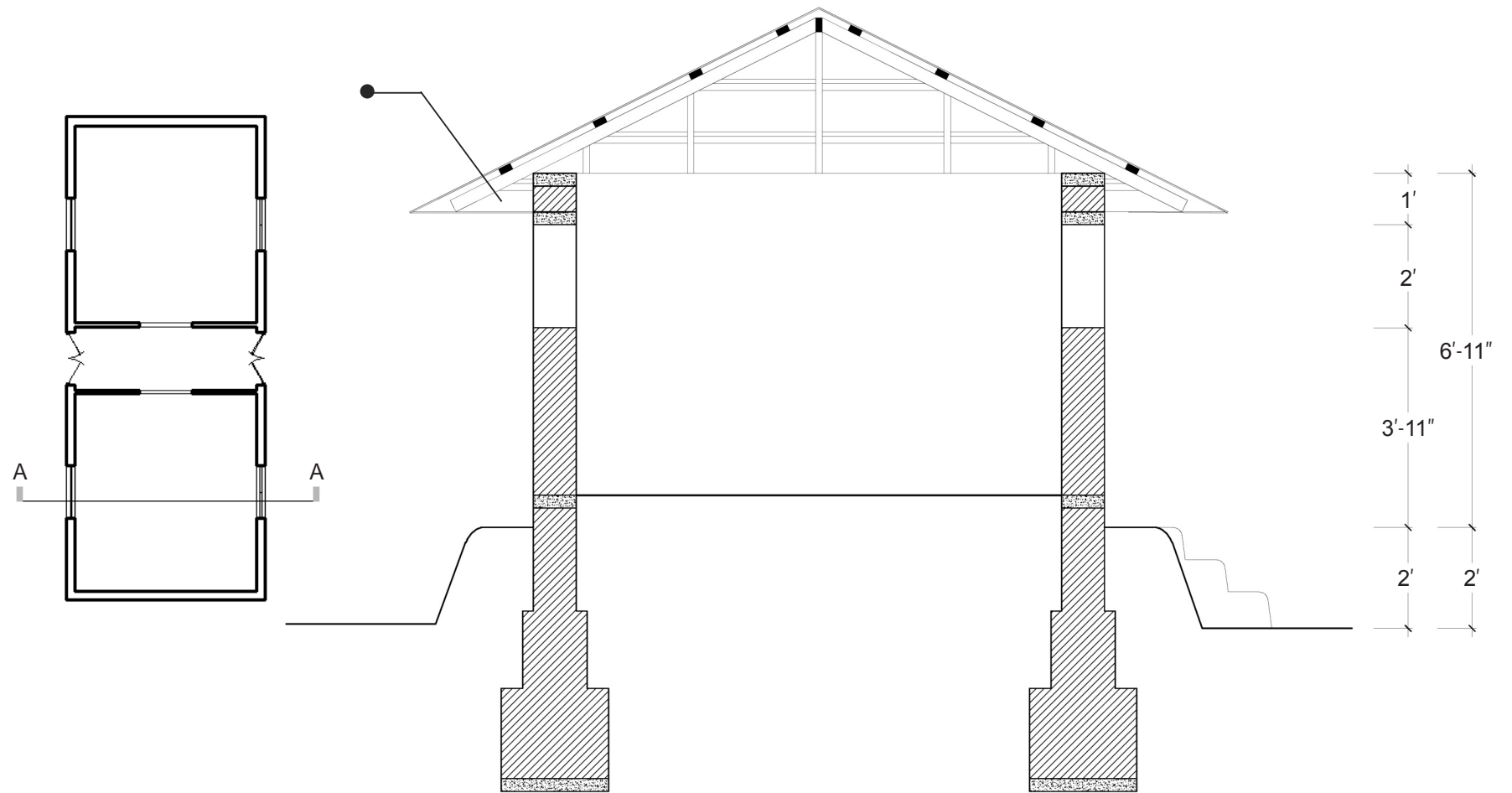

## SECTION OF ONE LAYER THICK LOAD BEARING STRUCTURE

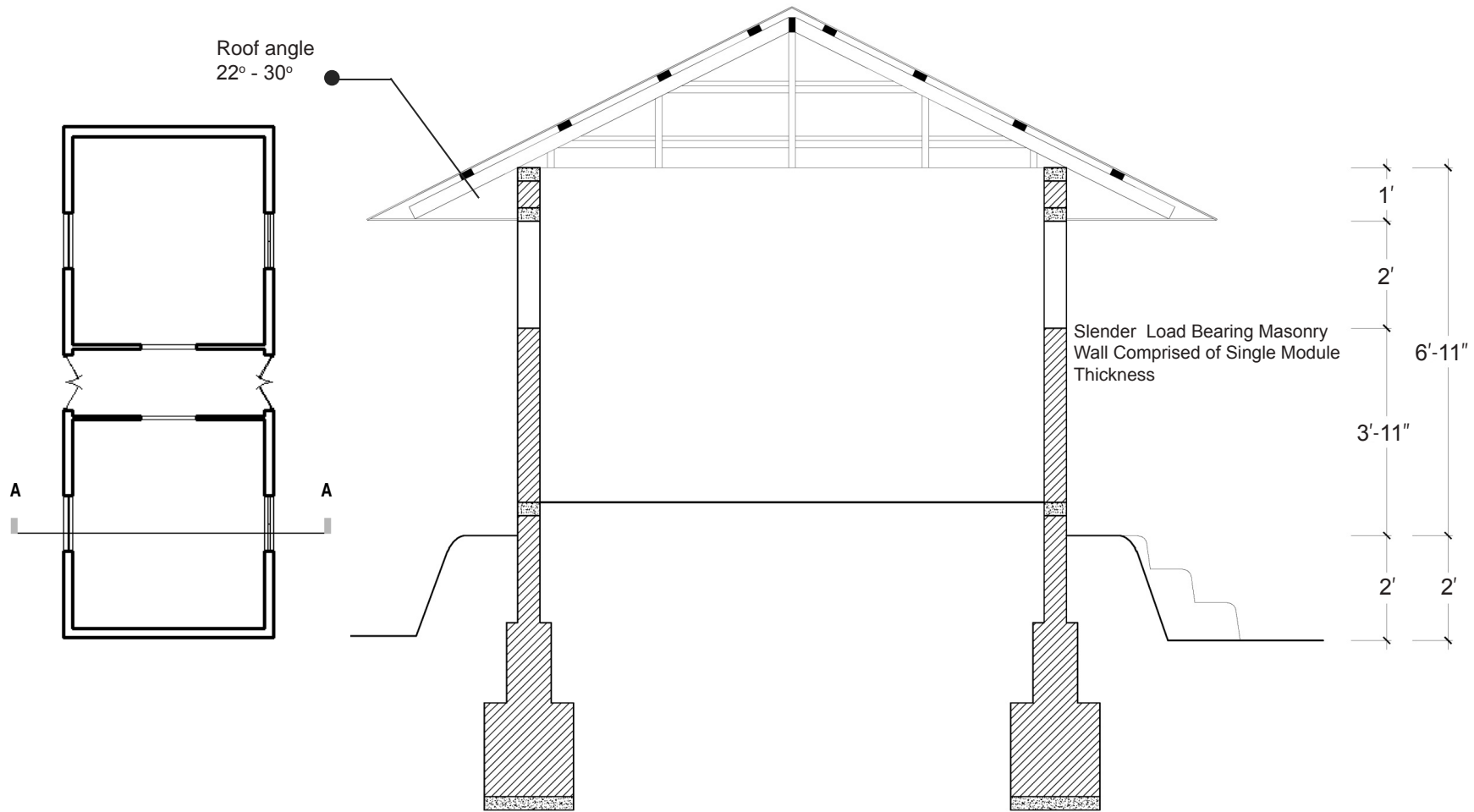

Section AA



## FORMATION OF HOUSE MODULE

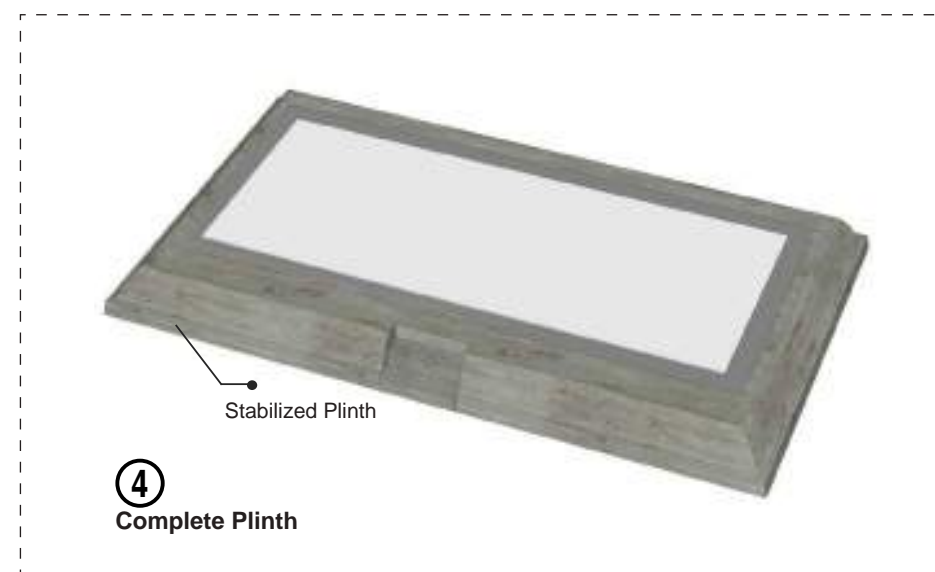
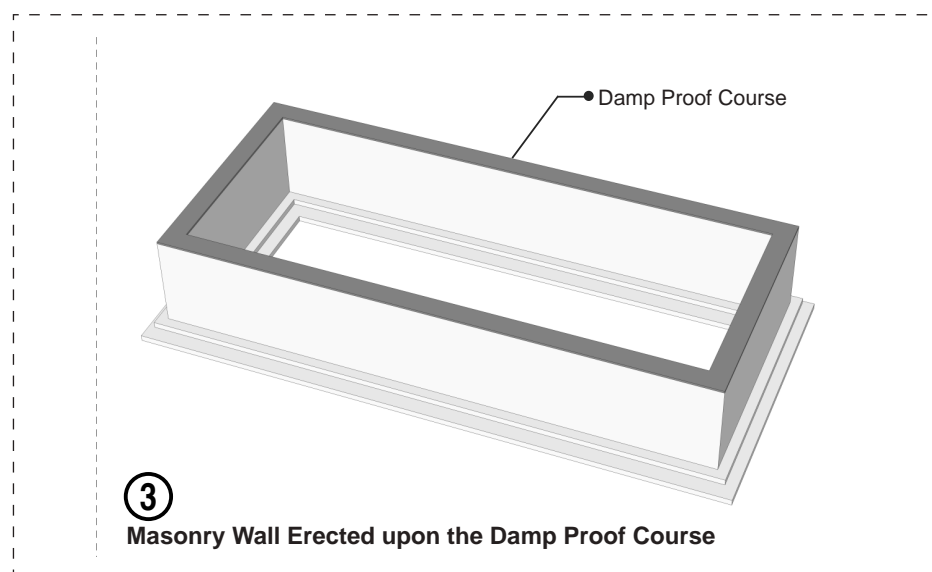
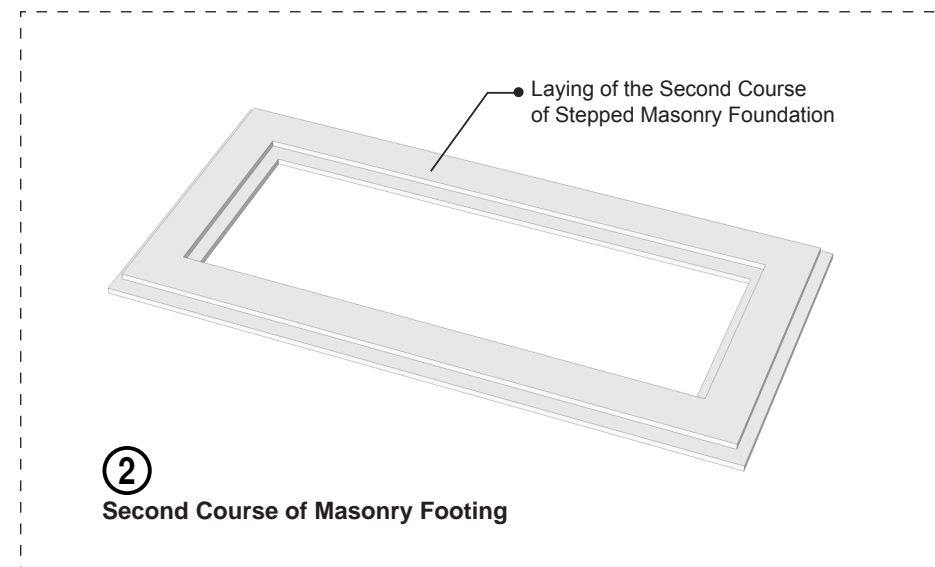
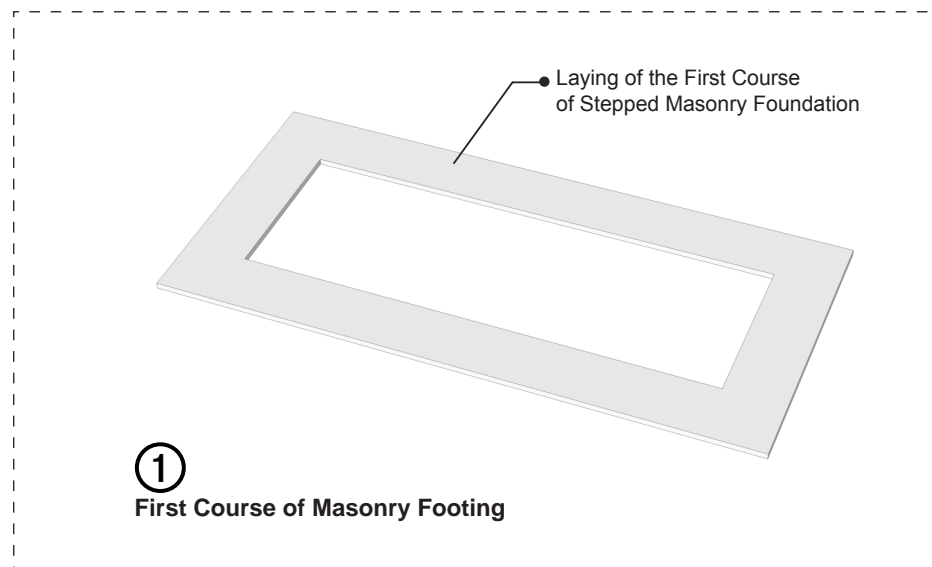

## FORMATION OF HOUSE MODULE (Contd...)

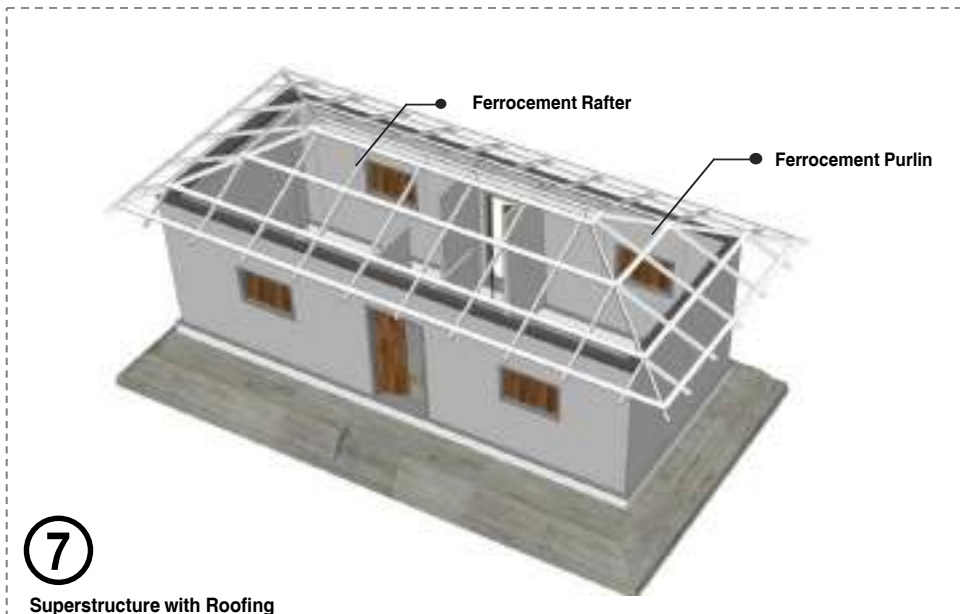
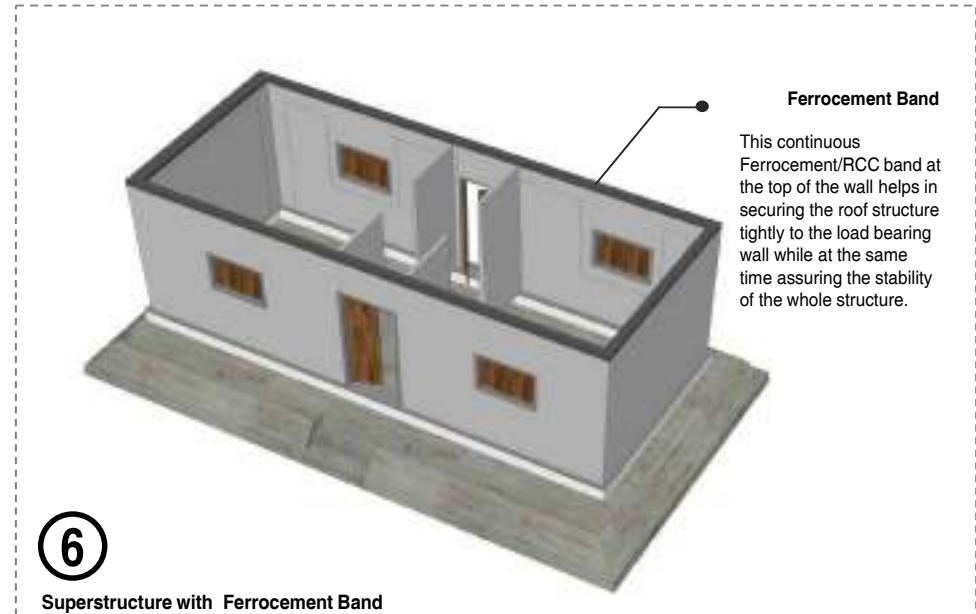
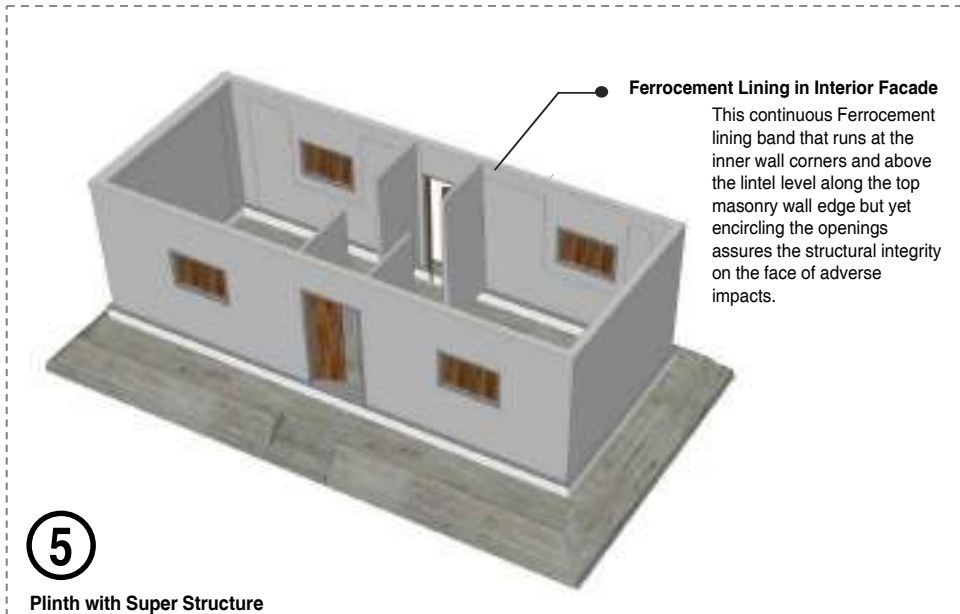

## LOAD BEARING HOUSE FORM MODEL 1

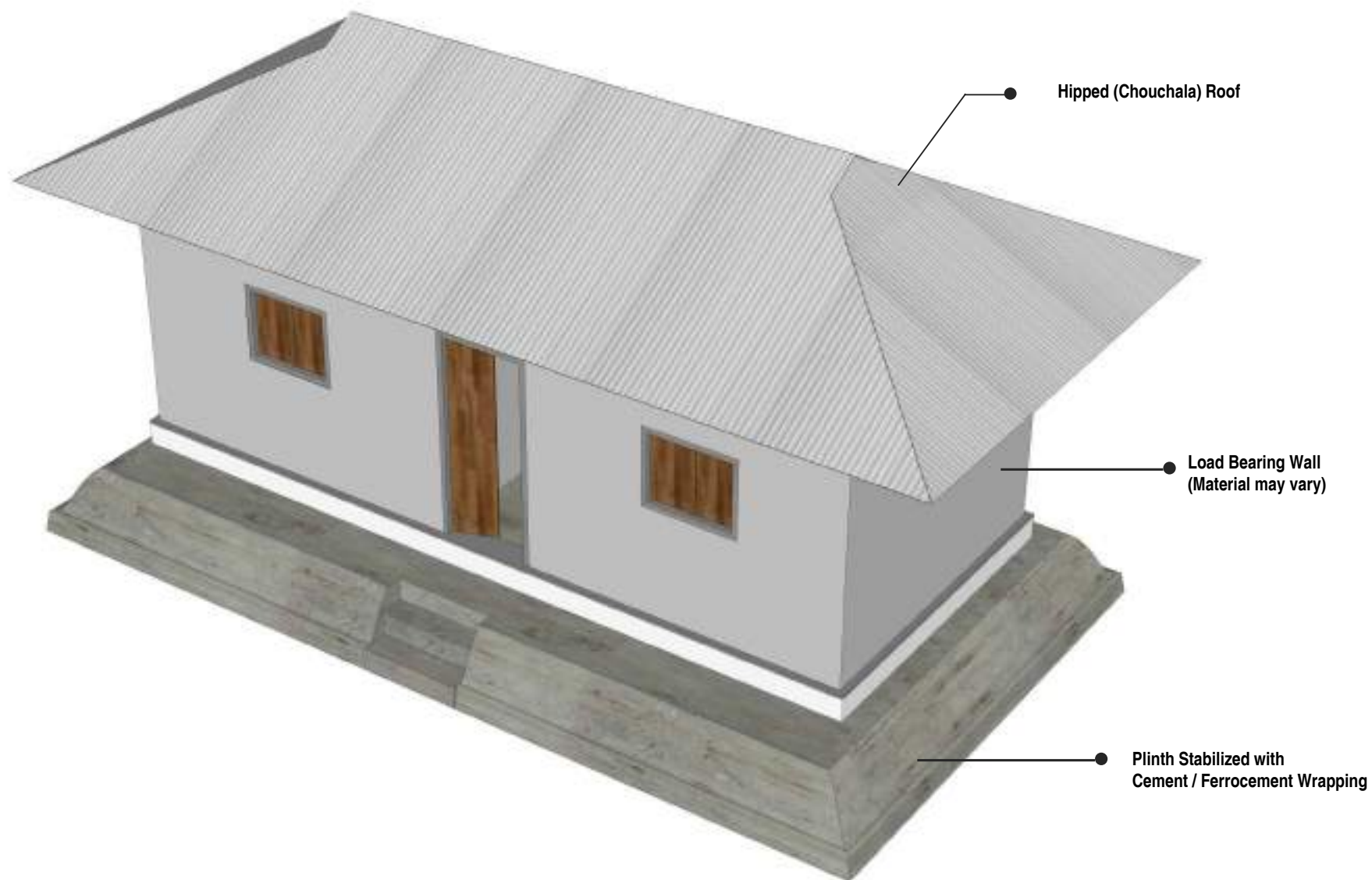

## FORMATION OF HOUSE MODULE WITH PASHCHATI

(see plan with Pashchati for frame structure, Pashchati width dimensions are similar for both of the house types)

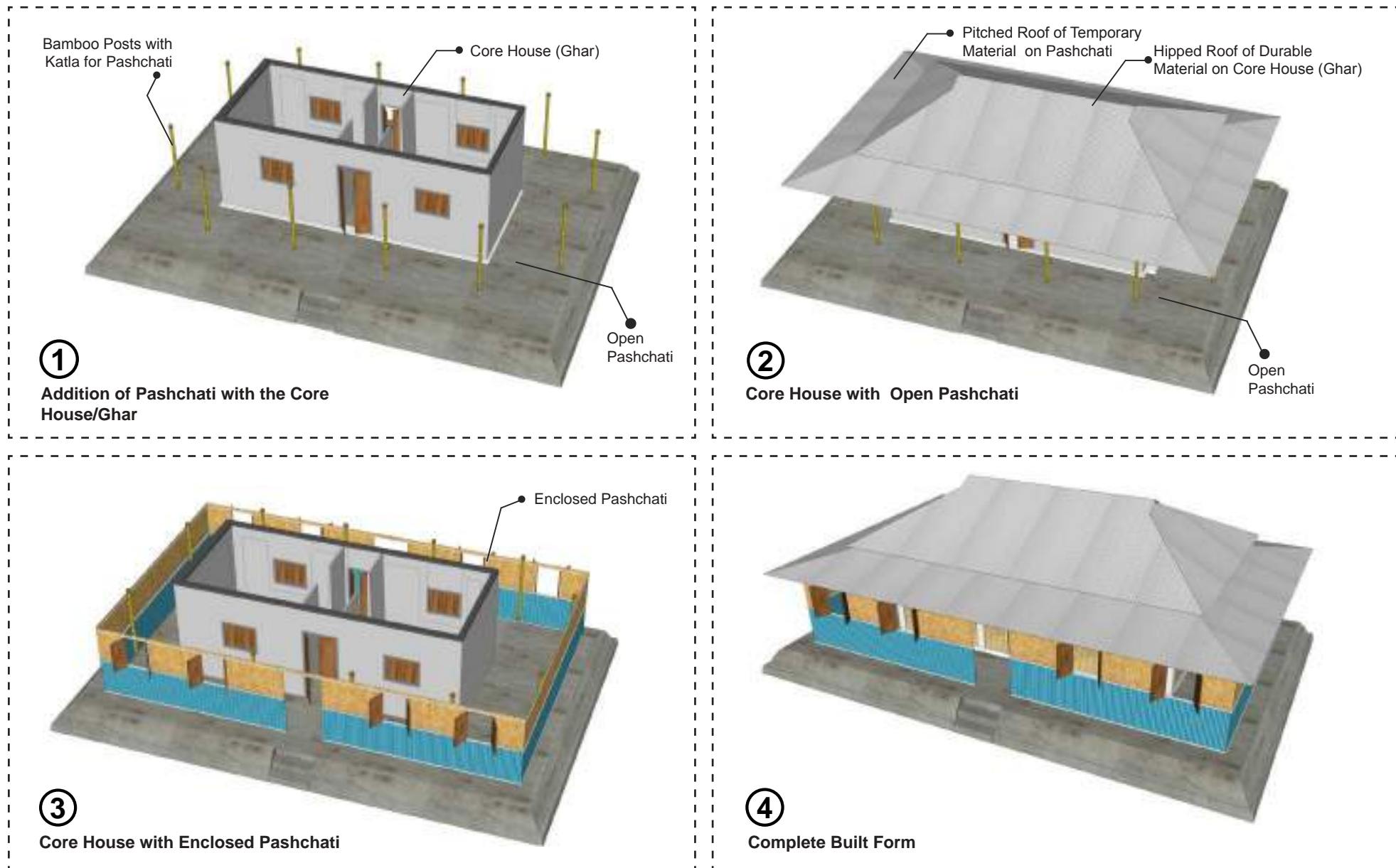

## PLAN

### MODEL 2

Model 2 is relatively small, single family and open plan dwelling unit (15'x9') where interior spaces can be organized according to inhabitant's need. Construction stages are same as previous.

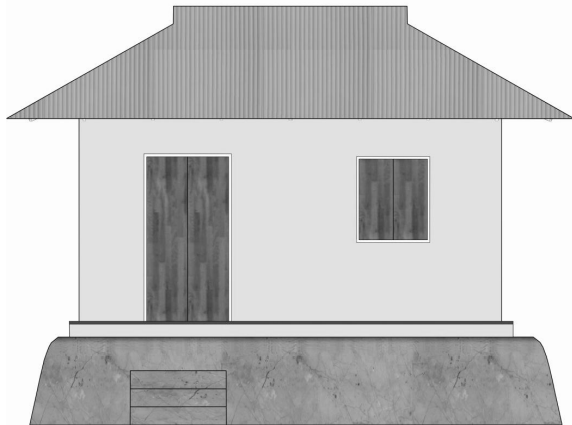

Front Elevation

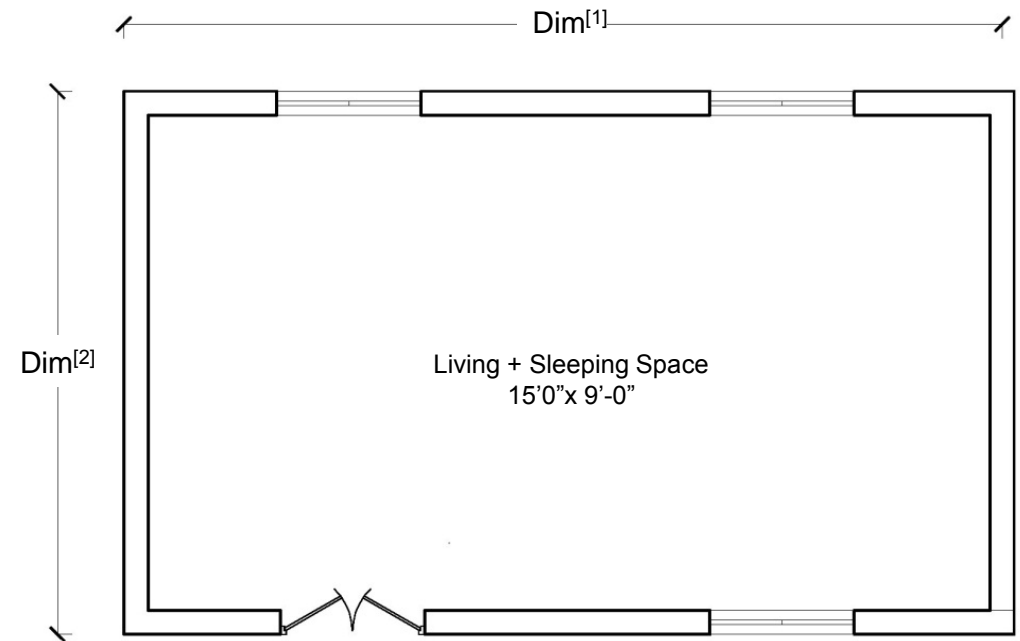

Plan for single family

### Model 2: House with Different Roofing Options



①

House form with Hipped Roof



②

House form with Gable Roof



③

House form with Mono Pitched Roof



## WALL ELEMENTS



**CSEB**

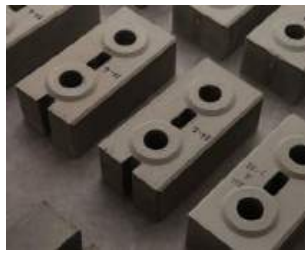

**CSEB Interlocking Block**



**Sand Cement Hollow Block**



**3D Panel**



**Sandwich Panel**



**CLC Block**

### For Pashchati



**CGI Sheet**



**Bamboo Matt**



**Bamboo Matt (Plastered)**

Note: The given material options are suitable as load bearing materials. For Pashchati non load bearing materials can be used. However the lower part of the exposed facade is suggested to be built with more durable material than the organic ones considering the salinity, rain water, moisture and other issues. For lower part Compressed Stabilized Earth Block (CSEB), colored CGI sheets can be used. Organic materials can be used in the upper portion of Pashchati as well.

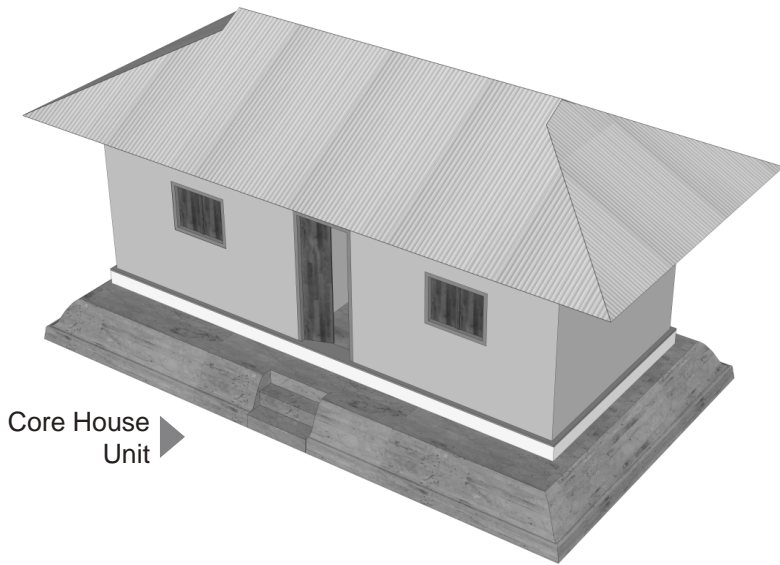

**Core House Unit**

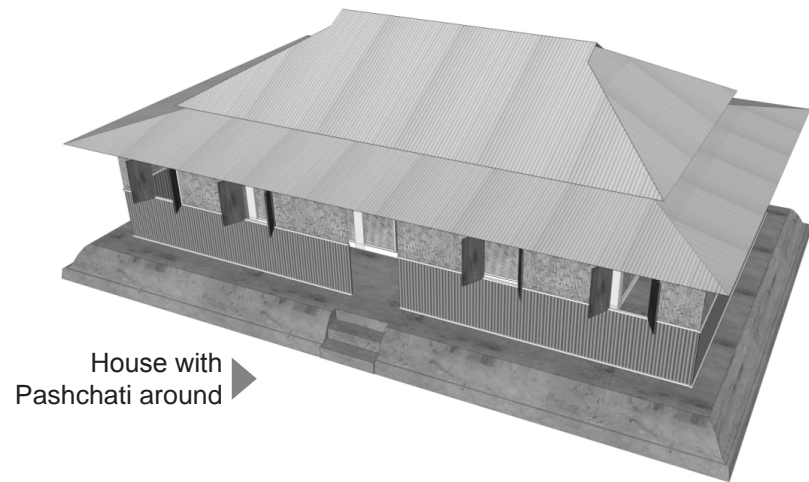

**House with Pashchati around**



### 2.6.2.3C Roofing Elements

#### HIPPED (CHOUCHALA) ROOFING ELEMENTS



Ferrocement Corrugated Sheet



Cast in-situ Ferrocement Roof

#### GABLE (DOCHALA) ROOFING ELEMENTS



Ferrocement Folded Plate



Ferrocement L-Panel

### 2.6.2.3D Engineering Drawings

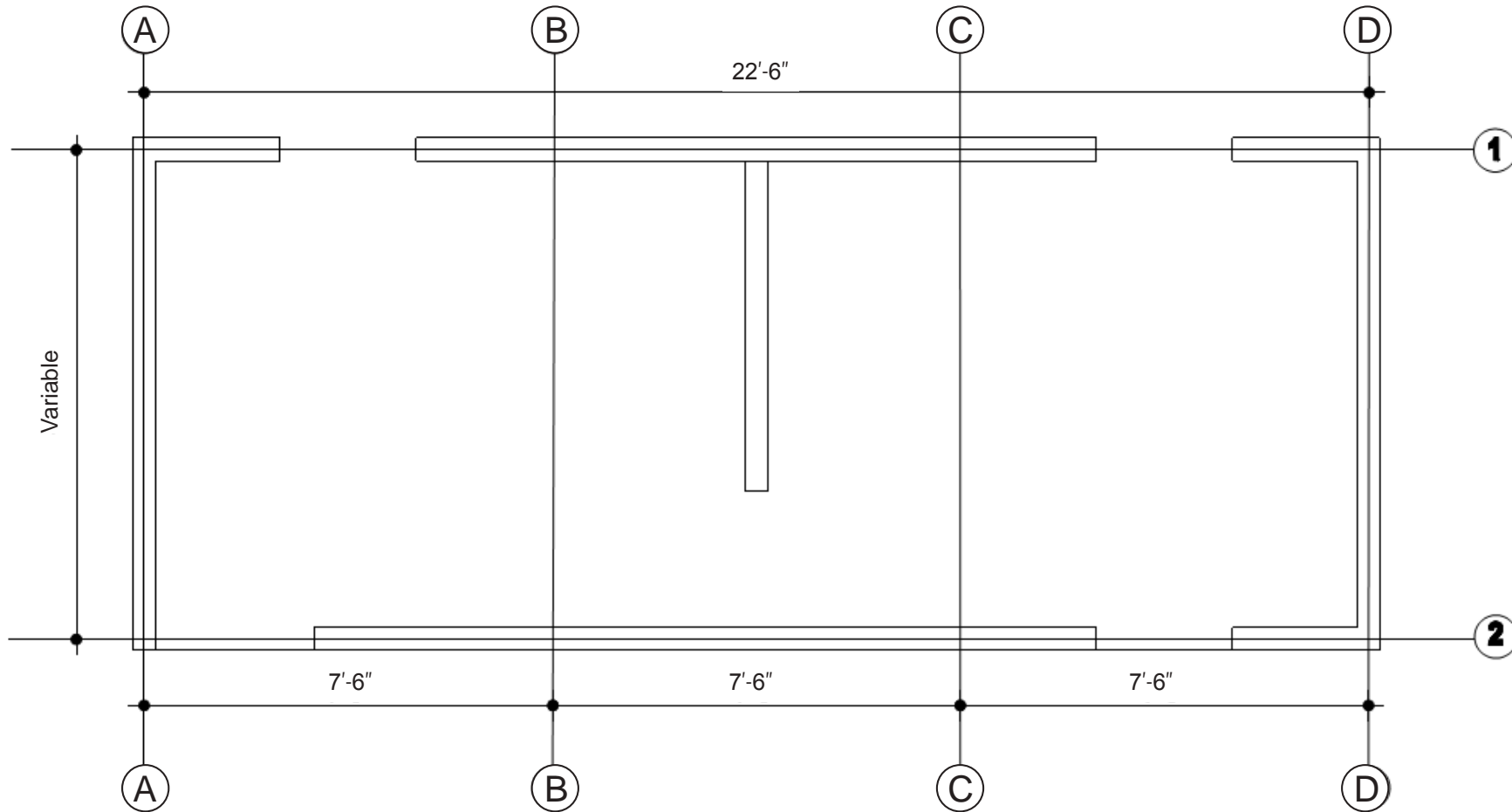

Load Bearing Structure Model 1

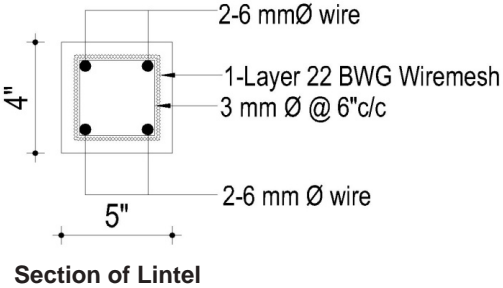
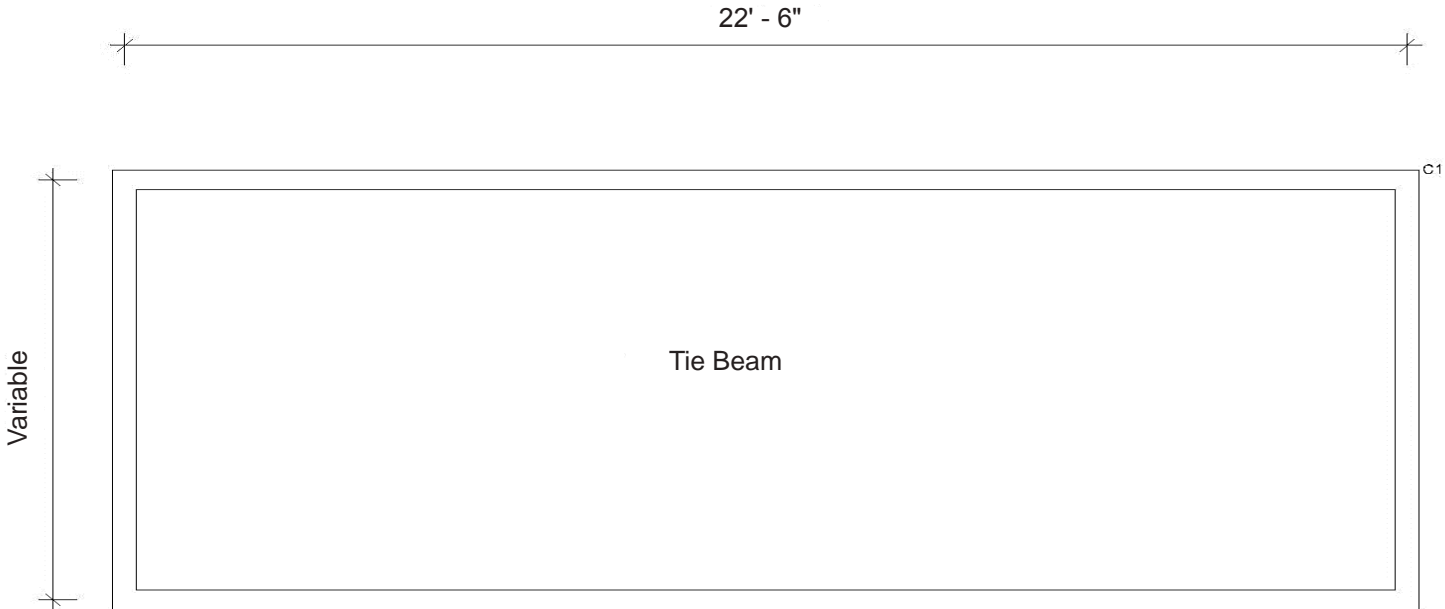





## 2.7 DESIGN RATIONALE

Out of all zones, the coastal zone represents maximum risk in terms of life casualties and other property damages. The population currently residing, finds their location for habitation at places of varying degree of risks; from the frontline of incoming impacts up to the areas much off shore. Therefore, while we can find people living outside the protection embankment or near to unprotected river edges; we can also find people having their homes on more permanent piece of land. At inland areas immense need for rehabilitation and relocation is still a prevailing demand. Also, people need stronger frame work of

house structure for more secured atmosphere of living. Considering all such issues, 2 model of house units have been proposed both for frame work and load bearing structure; one of larger dimensions and other of lesser dimensions. The Model 1 house unit, with higher dimensions, has been conceived for more stable locality while the Model 2 house unit or the small house model has been worked out for rehabilitation or relocation programs; targeting bare-minimum population. The prevailing local practice of incorporating an extra semi-out door, semi-covered space naming 'Pashchati' around the main house

unit has also been demonstrated at the given Design schemes, this particular feature provides extra space for coping service spaces like kitchen, chicken coop, storage or extra sleeping space etc. Apart from acting as an extra protection barrier from cyclone impacts. The dimension of the proposed house model was derived largely in accordance with local unit of measurement (1 haat = 1'-6") apart from providing a compact space for conducting a secured living.



CHAPTER THREE

# DESIGN FOR FLOOD PLAIN AND CHAR AREAS

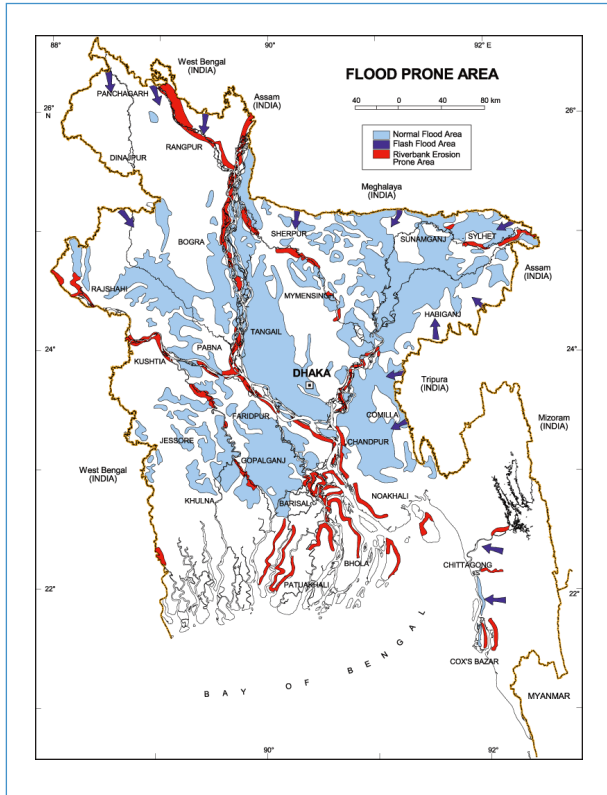

## 3.1 GEOGRAPHIC PROFILE

Flood is one of the most significant natural phenomena in the country causing extensive damage to human life and property. It usually occurs during the monsoon season. The country lies on the downstream part of three major river basins: Brahmaputra(Jamuna), Ganges(Padma) and Meghna and thus is frequently flooded. There have been many destructive floods in Bangladesh, including very severe floods of 1987, 1988 and 1998. There are two types of floods which occur in Bangladesh: annual floods (barsha) that inundate up to 20% of the land area; and low frequency floods of high magnitude that inundate more than 35% of the area (bonna). The major floods that occurred in 1954, 1955, 1974, 1984, 1987, 1988, 1993, 1998, 1999, 2000 and 2007 have been very destructive and caused serious threat to lives and economy.

## 3.2 CLIMATIC FACTORS FOR DESIGN CONSIDERATIONS

The generic and case specific climatic features of flood affected regions that can affect the design task are:

- ▶ Flood
- ▶ Intense Radiation
- ▶ Nor westerly
- ▶ Sand Heat
- ▶ Lateral water pressure
- ▶ Humidity
- ▶ River Erosion
- ▶ Driving Rain

## 3.3 HAZARD PROFILE

Floods directly affect existing human living conditions by causing numerous damages like tearing down and washing away the house structures and other form of physical properties. It also takes its toll upon lives of livestock and human beings by causing irreparable casualties. The flood damage potential in Bangladesh is increasing due to the possible causes of climate change, urban concentration in the three river basins, encroachment of flood plain lands for settlement purposes and overreliance on the safety provided by flood control works such as levees, reservoirs.



### 3.4 PREVAILING PRACTICES

#### ■ Local Practices

- ▶ Gable roof is commonly used.
- ▶ Raised homestead for community houses.
- ▶ Minimum plinth height ensured in houses.
- ▶ CGI sheet used mostly as roofing and wall material.
- ▶ Bamboo/RCC post both are used as structural element.
- ▶ Use of locally available material for wall and roofing.

#### ■ Introduced Housing by Different GOs and NGOs

- ▶ Total Community is raised on a high/raised earthen mound with plastered cement in perimeter.
- ▶ Buttressed supported retaining wall for the raised settlement mound
- ▶ CGI sheet as roofing and wall material.
- ▶ RCC post as structure.

#### ■ Community Feedback

- ▶ Houses should be near work places as many previous examples were found unsuccessful.
- ▶ Houses should be in the inner areas of the dam/embankments.
- ▶ Minimum plinth height 2' ( height might vary in case of low lying areas and flood level, base should be properly prepared)

- ▶ Plinth should be fully stabilized/pucca.
- ▶ Cross bracing of appropriate materials needs to be used.
- ▶ Unavailability of coarse sand in Char Area.
- ▶ Develop expertise in locality.
- ▶ As most of the inhabitants are farmers, there should be provision for storing agricultural stuffs.

#### ■ Issues Identified

- ▶ Removable structure is needed for Char area owing to transient nature of the landscape.
- ▶ Issues like unavailability of coarse sand, quick removability of house structure calls for introducing prefabricated building elements.
- ▶ Durable structural members concerning issue of longer house lifespan.
- ▶ Structural members to be fastened to each other properly.
- ▶ Additional structural stability to be ensured by the means of introducing bracing elements at due strategic points.
- ▶ Mound raising should be undertaken to establish new settlements.



Existing Local Practices in Flood Plain/Char Regions

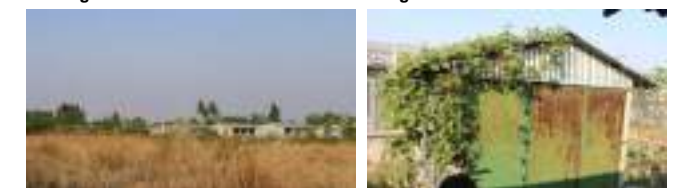

Asrayan Prokolpo by Government



Housing by Friendship

### 3.5 DESIGN CONSIDERATIONS

- ▶ Consideration for emergency-situation-responsive quick installation and dismantling processes
- ▶ Portability of building elements
- ▶ Development of standardized and labor friendly pre-fabricated mode of construction using minimum/economic building elements
- ▶ Addressing contextual issues e.g. river erosion, flood etc.
- ▶ Climate responsive design approach

### 3.6.1 Frame Structure

#### 3.6.1.1 Plan (for Area 1 & Area 3)

##### MODEL 1

The typical house plan is designed considering the local spatial needs including storage spaces both at floor area and overhead platforms. This overhead platform, in specific cases is accompanied by an overhead exit door to help inhabitants taking refuge in the time of severe flooding periods.

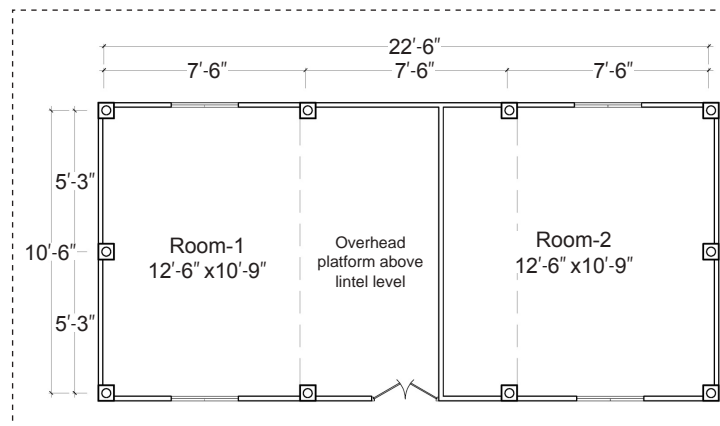

##### MODEL 2

An alternative to model 1 is a single family simple dwelling unit (12'-0"x10'-0") that can be self organized according to inhabitant's need. Construction stages are same as model 1.

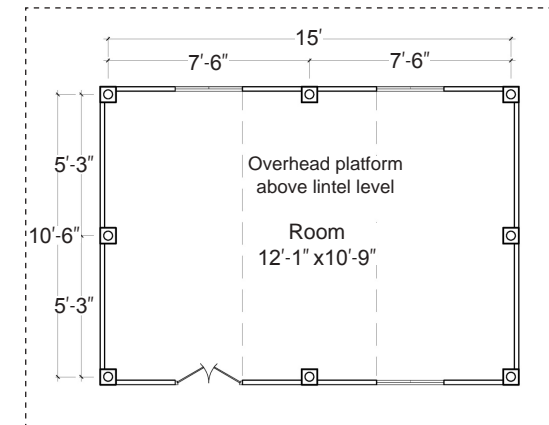

### 3.6 BUILDING TYPOLOGY

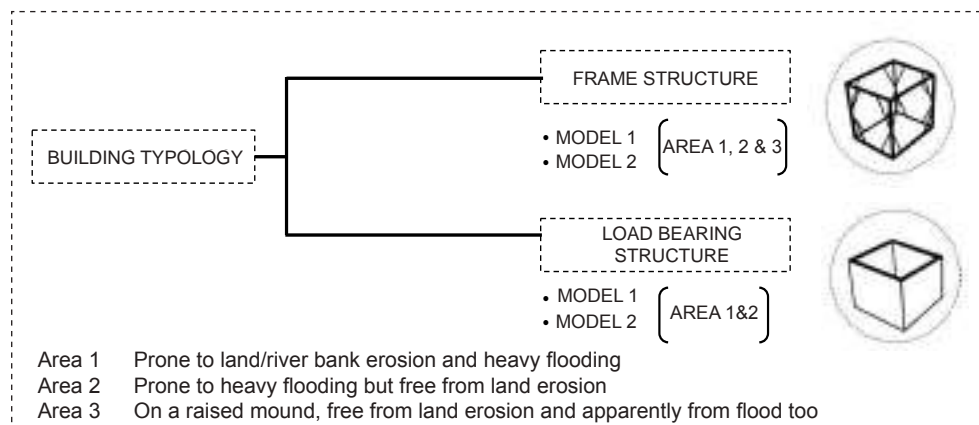

**SECTION OF FRAME STRUCTURE: MODEL 1**  
 (Area 1 \_with Emergency Escape)

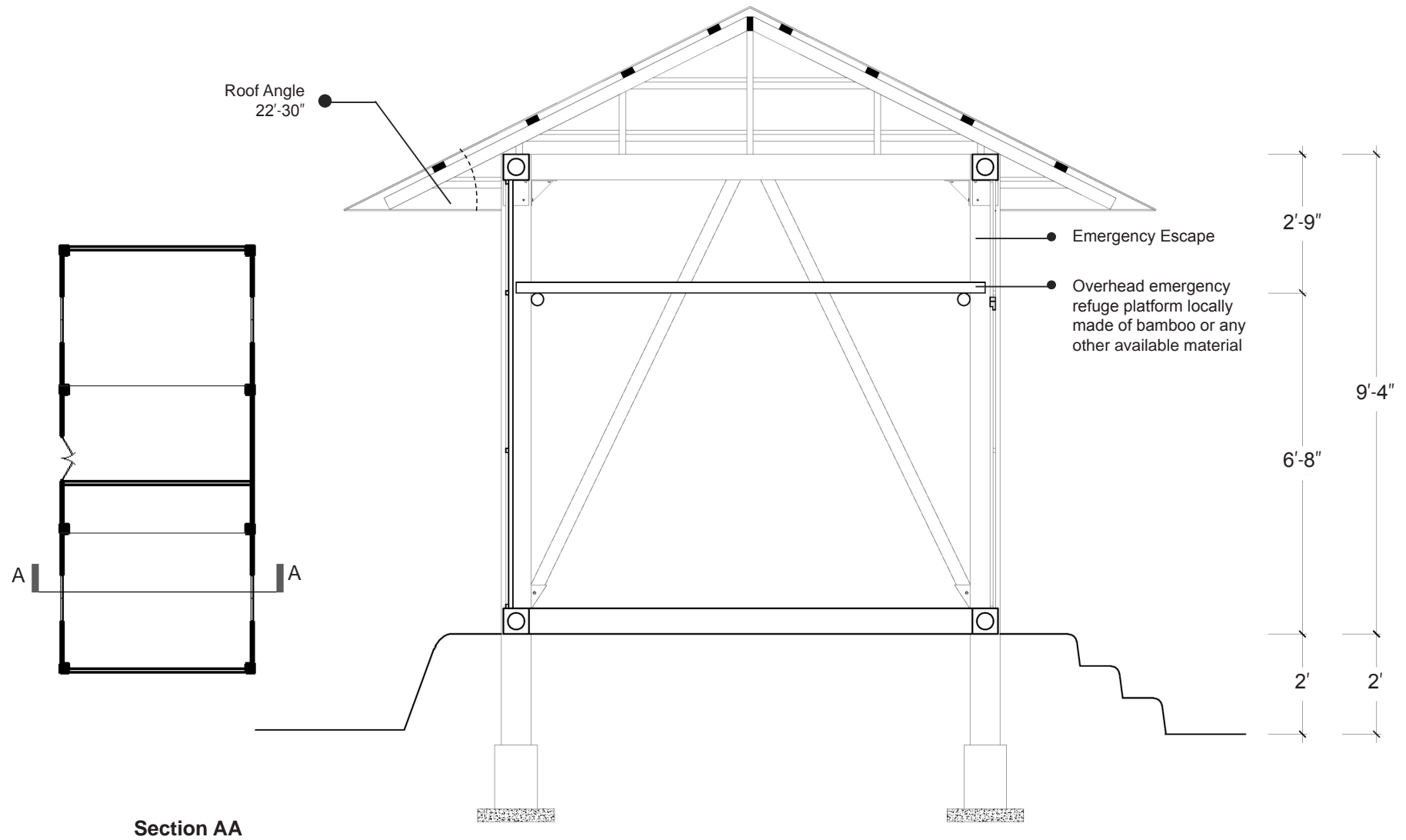



## FORMATION OF HOUSE MODULE

(Model 1\_Area 1)

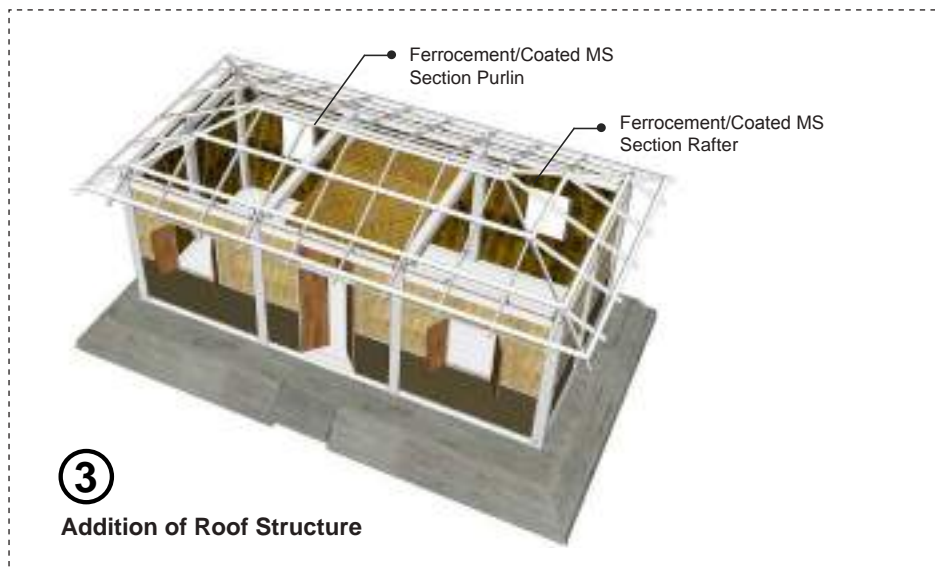
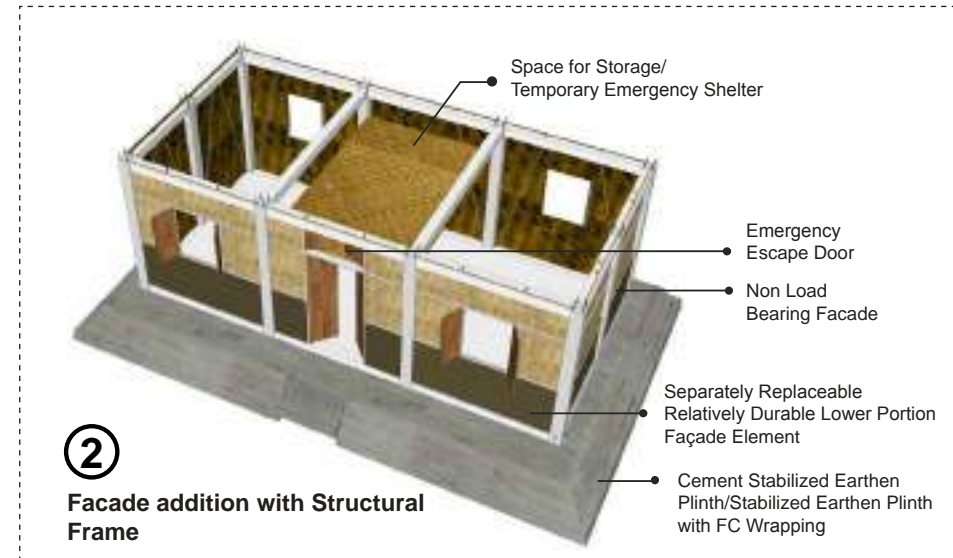
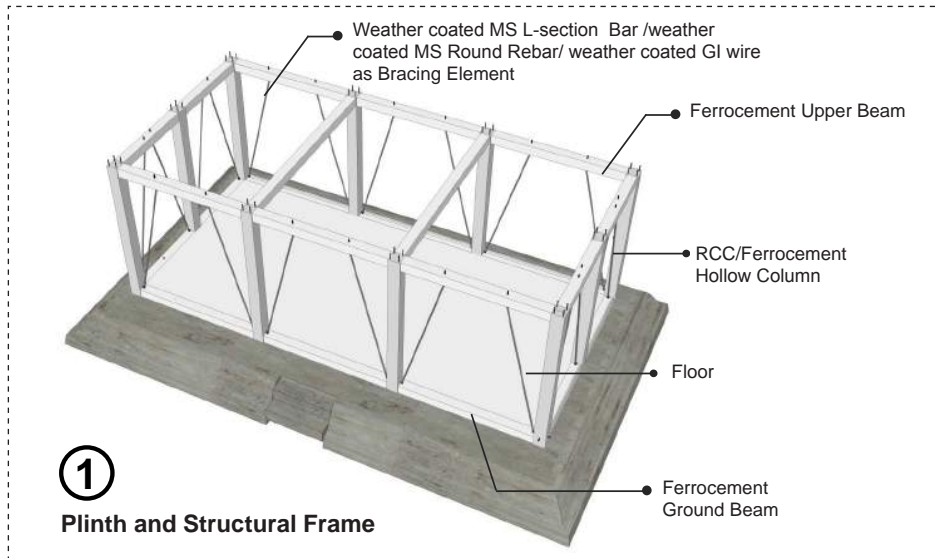

## FORMATION OF HOUSE MODULE (Model 1\_Area 3)

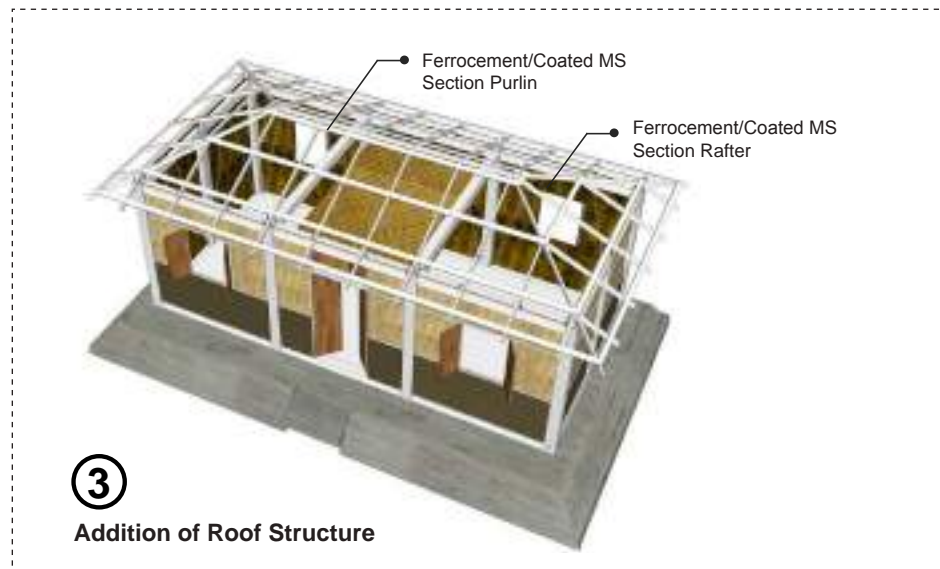
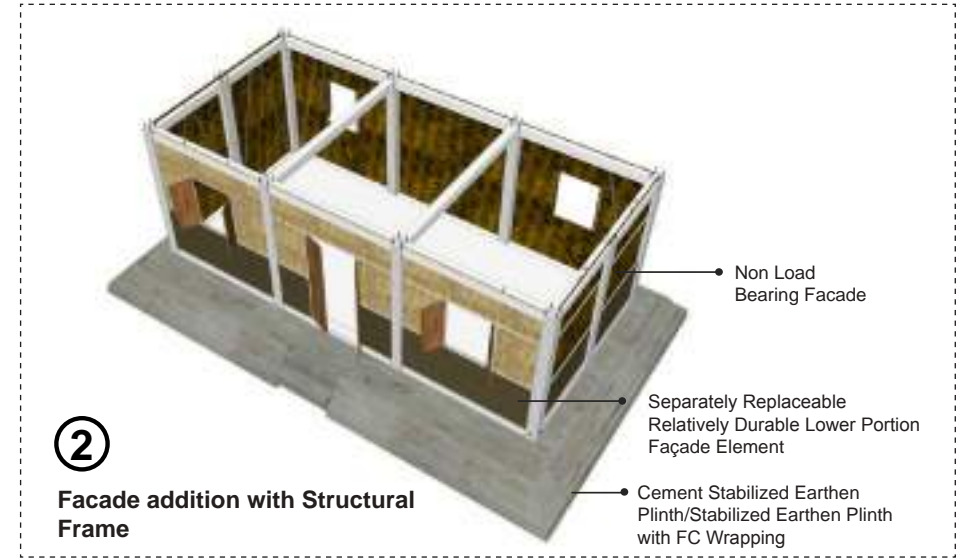
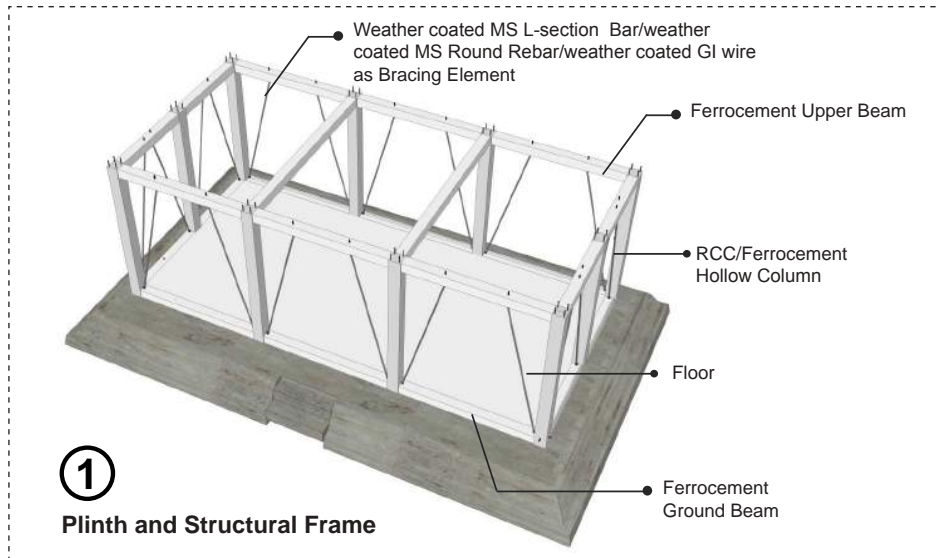



**Model 1\_Area 1 & 2**



House Form with Gable Roof (with Emergency Escape) ▶

**Model 1\_Area 3**



House Form with Gable Roof (without Emergency Escape) ▶

**Model 2\_Area 1**



House Form with Hipped Roof (with Emergency Escape) ▲



House Form with Gable Roof (with Emergency Escape) ▲



House Form with Hipped Roof (without Emergency Escape) ▲

**Model 2\_Area 3**



House Form with Gable Roof (without Emergency Escape) ▲

### 3.6.1.2 Building Elements

#### 3.6.1.2A Structural Elements

For following structural elements of Frame structure, see section 3.6.1.3A of chapter 3 (Design for Coastal Areas)

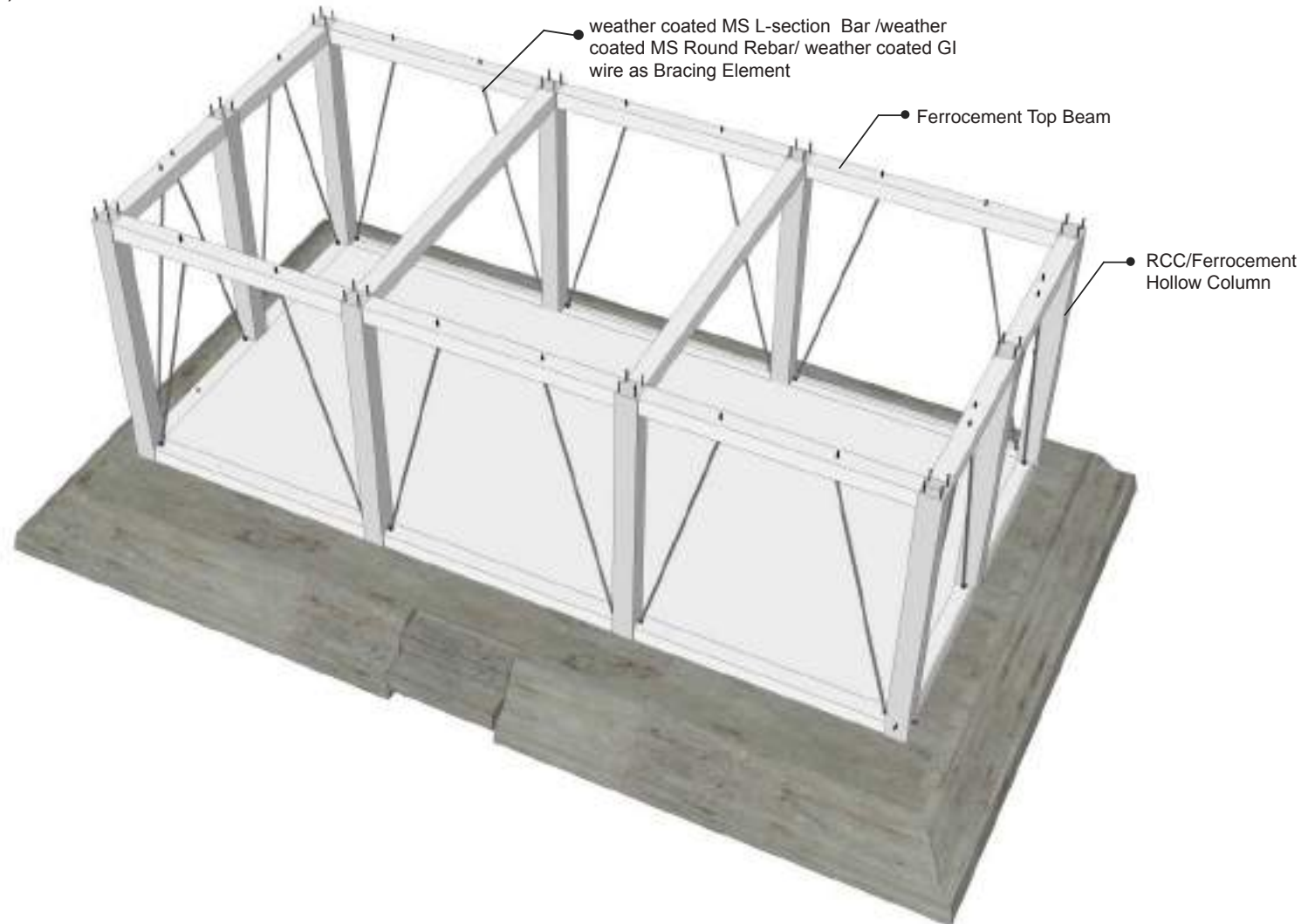

### 3.6.1.2B Wall Elements



For Area 1 ,2 & 3

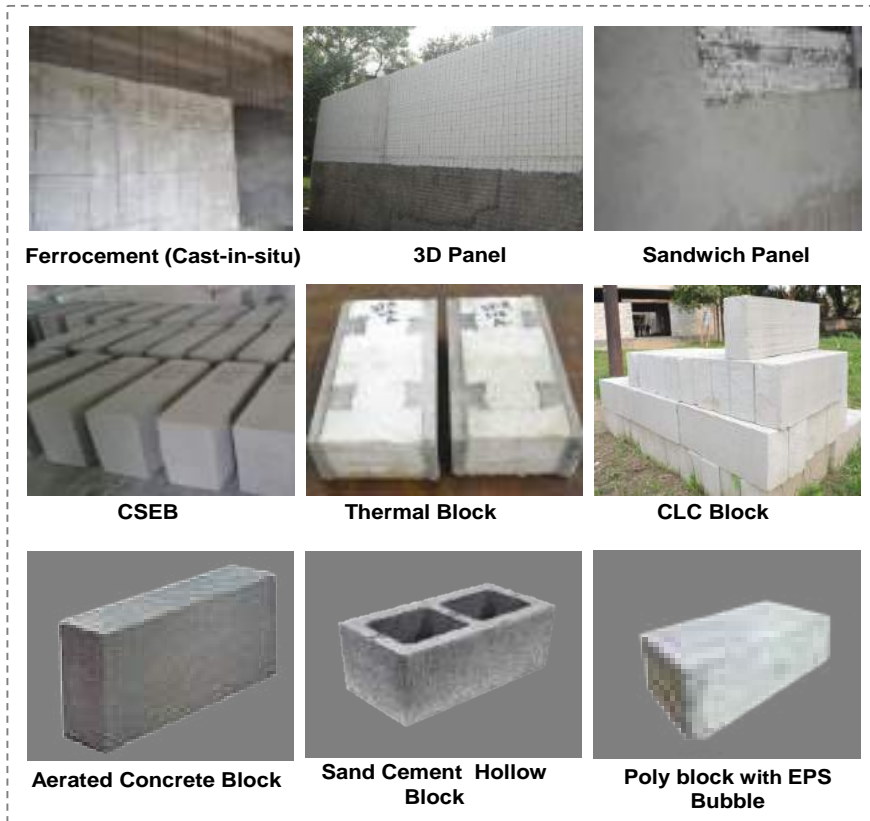

For Area 2 & 3

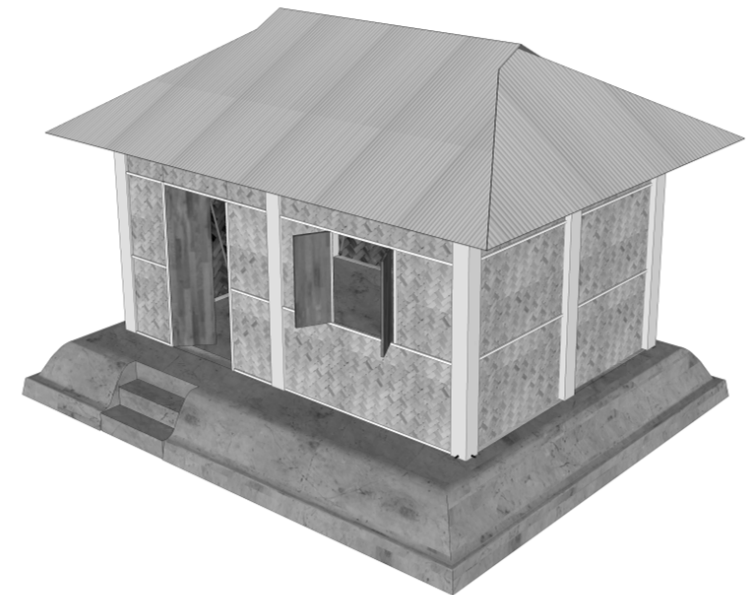
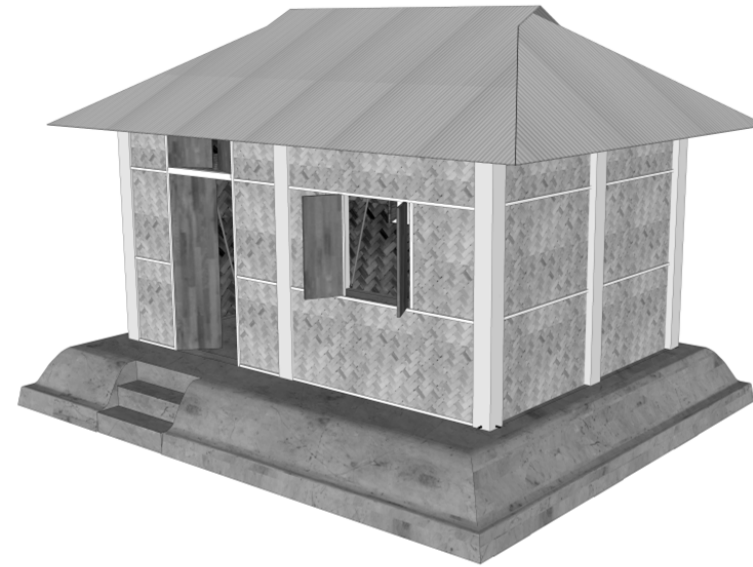

### 3.6.1.2C Roofing Elements

#### Hipped (Chouchala) Roofing Elements



Ferrocement Corrugated Sheet



Cast in-situ Ferrocement Roof

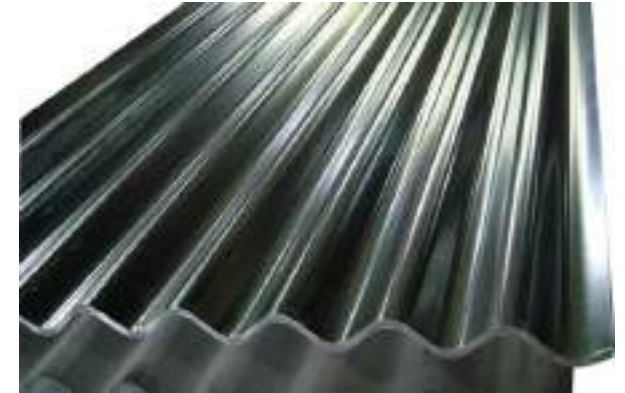

CGI Sheet

#### Gable (Dochala) Roofing Elements



Ferrocement Folded Plate



Ferrocement L-Panel



Processed Thatched Roof



### 3.6.1.3 Technical Drawings

#### 3.6.1.3A Joinery Details

For following Joinery Details of Frame structure, see section 2.6.1.4A of chapter 2 (Design for Coastal Areas)

#### 3.6.1.4 Engineering Drawings

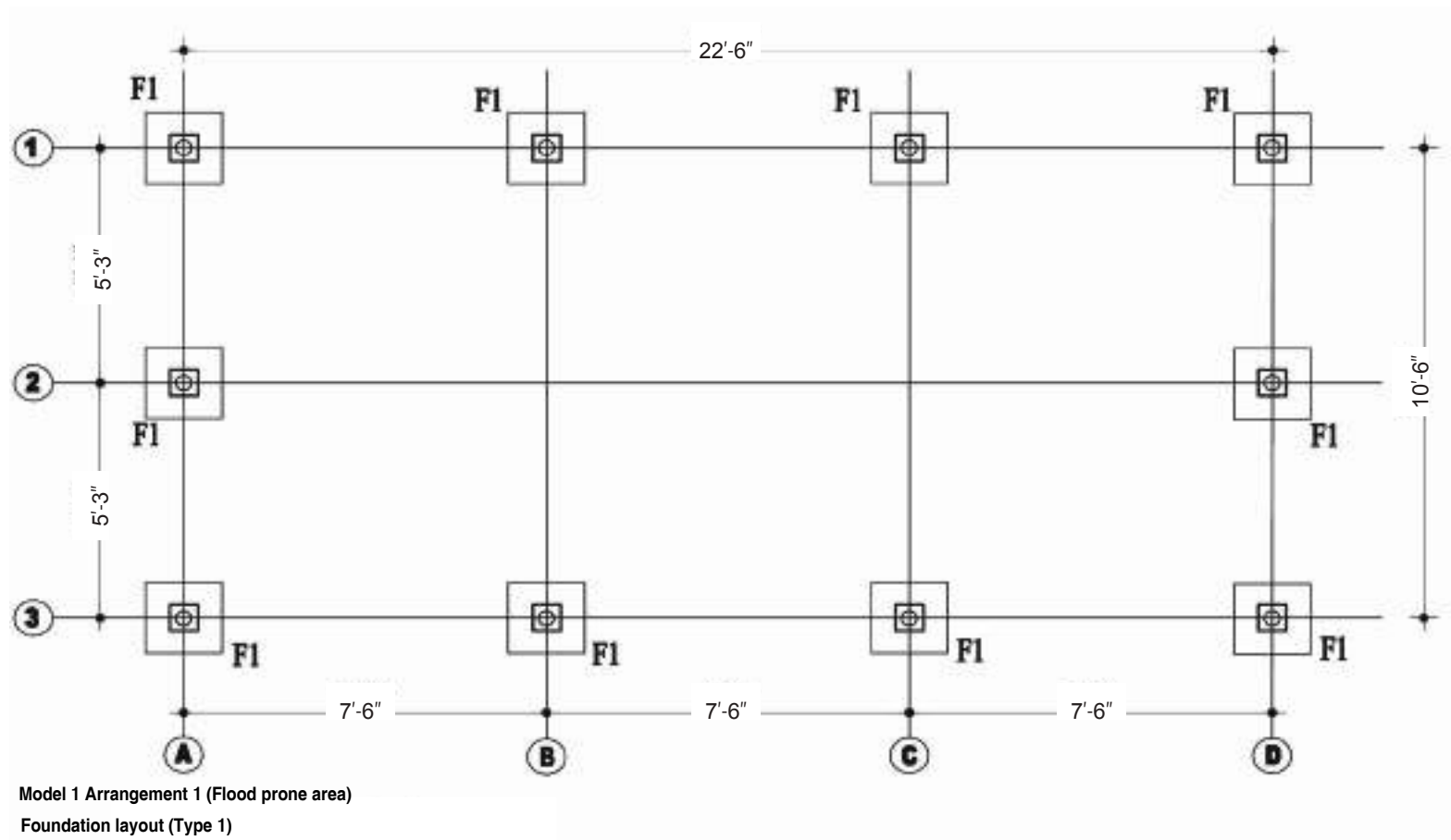



## FOUNDATION LAYOUT (Type 2)

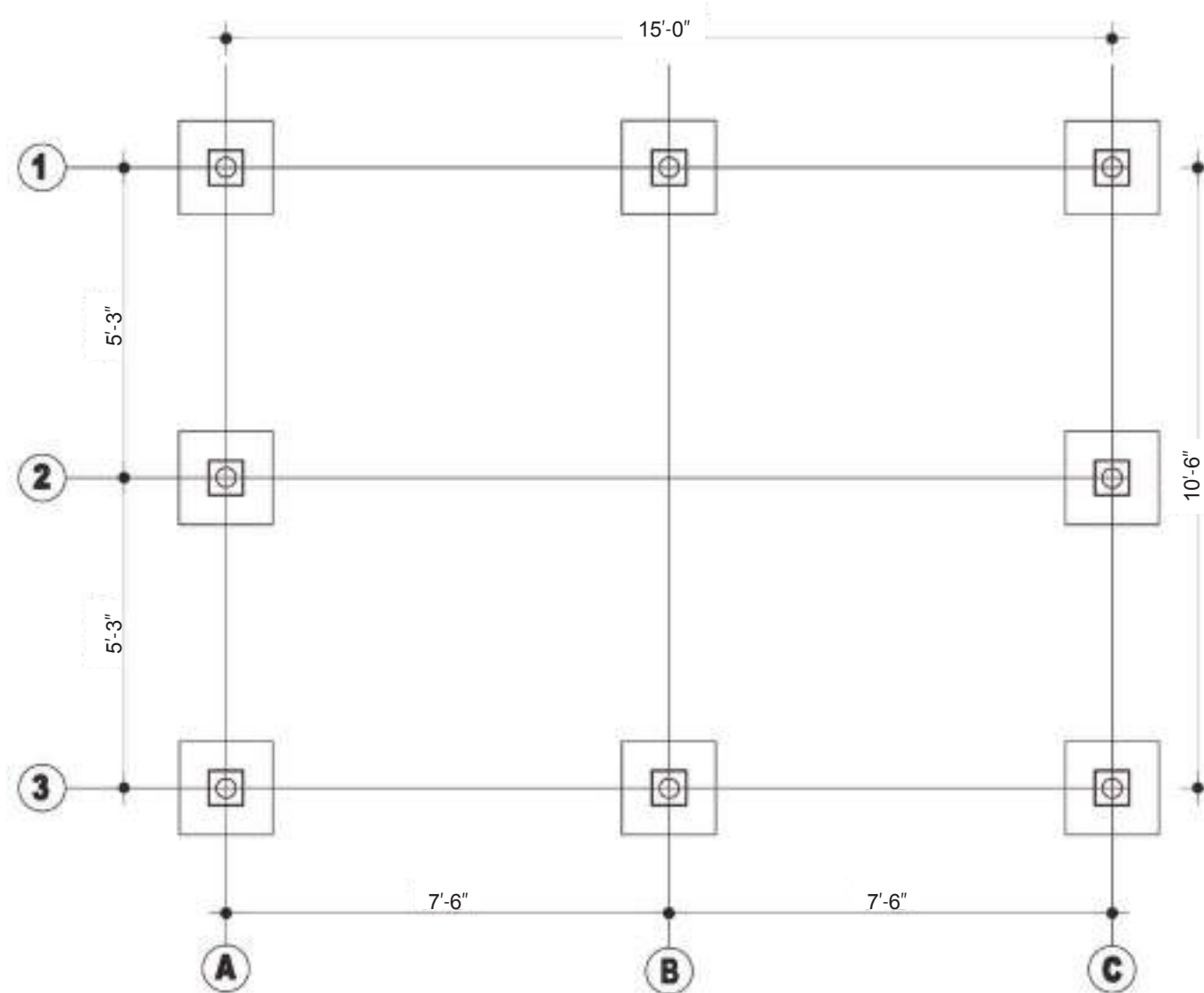

Foundation layout (Type 2)

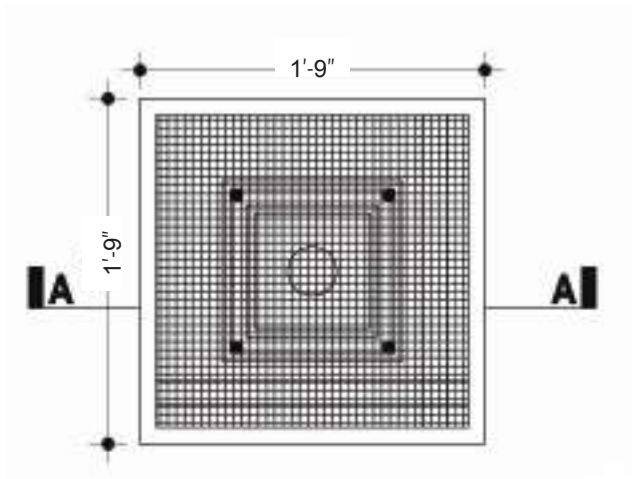

Plan of FC pocket footing F1

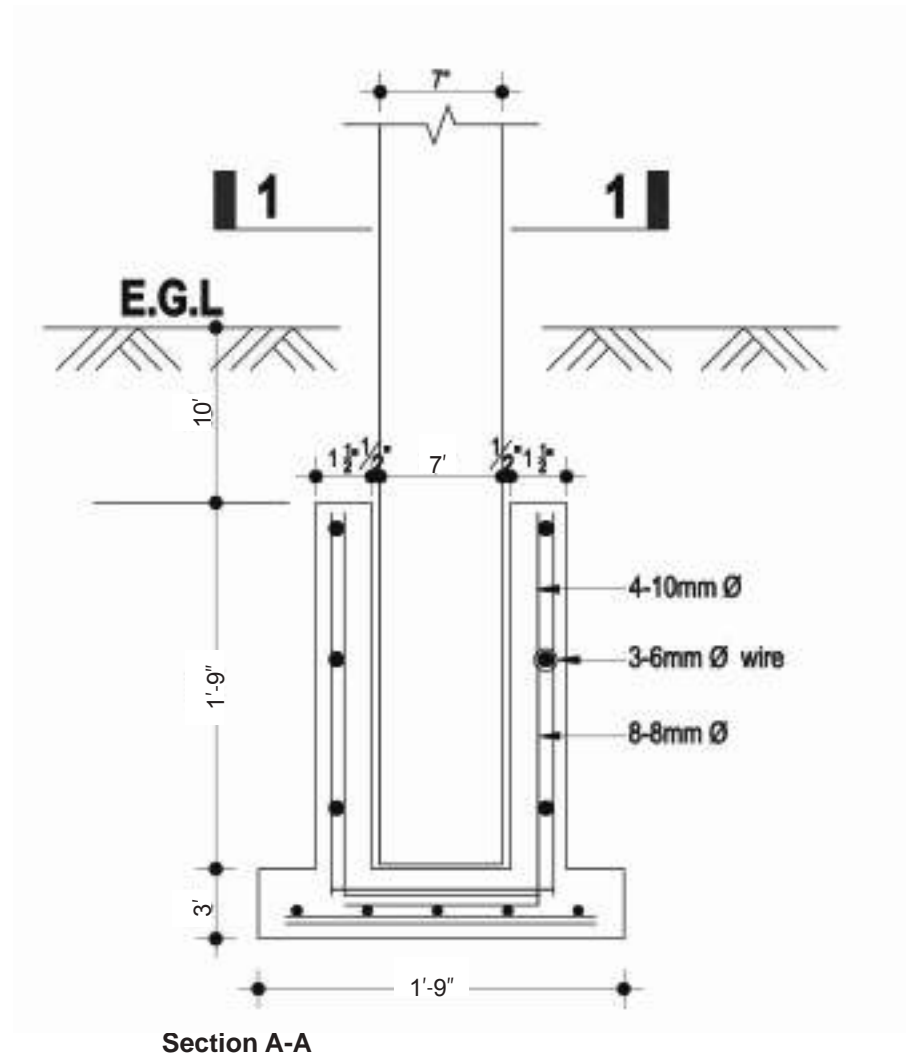

Section A-A

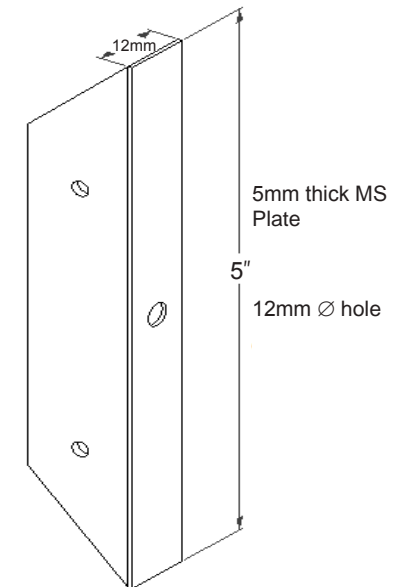
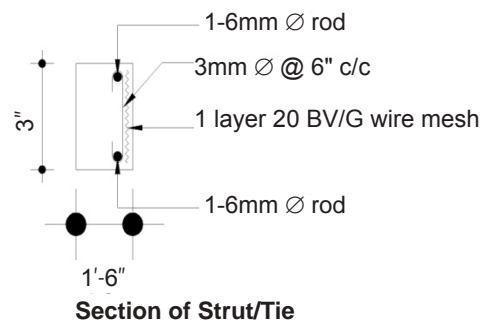
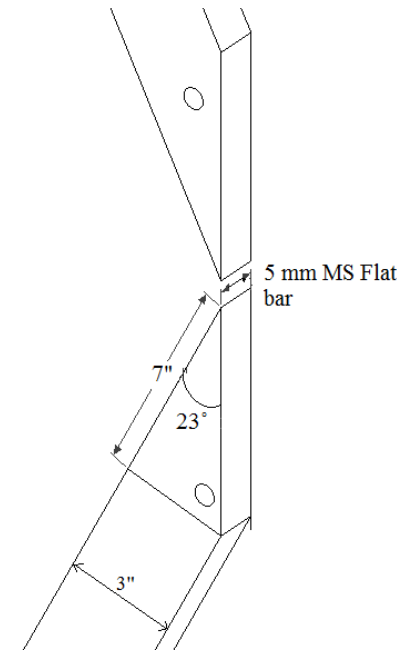
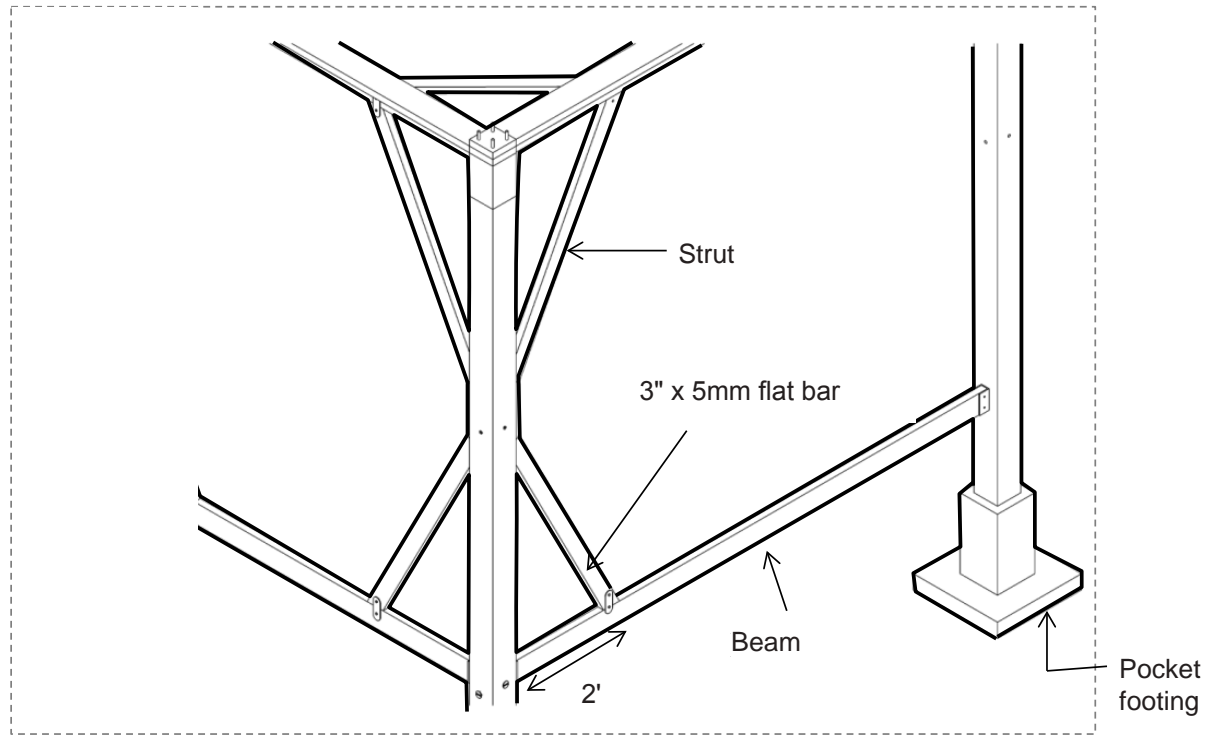

## LOAD BEARING STRUCTURE MODEL 1

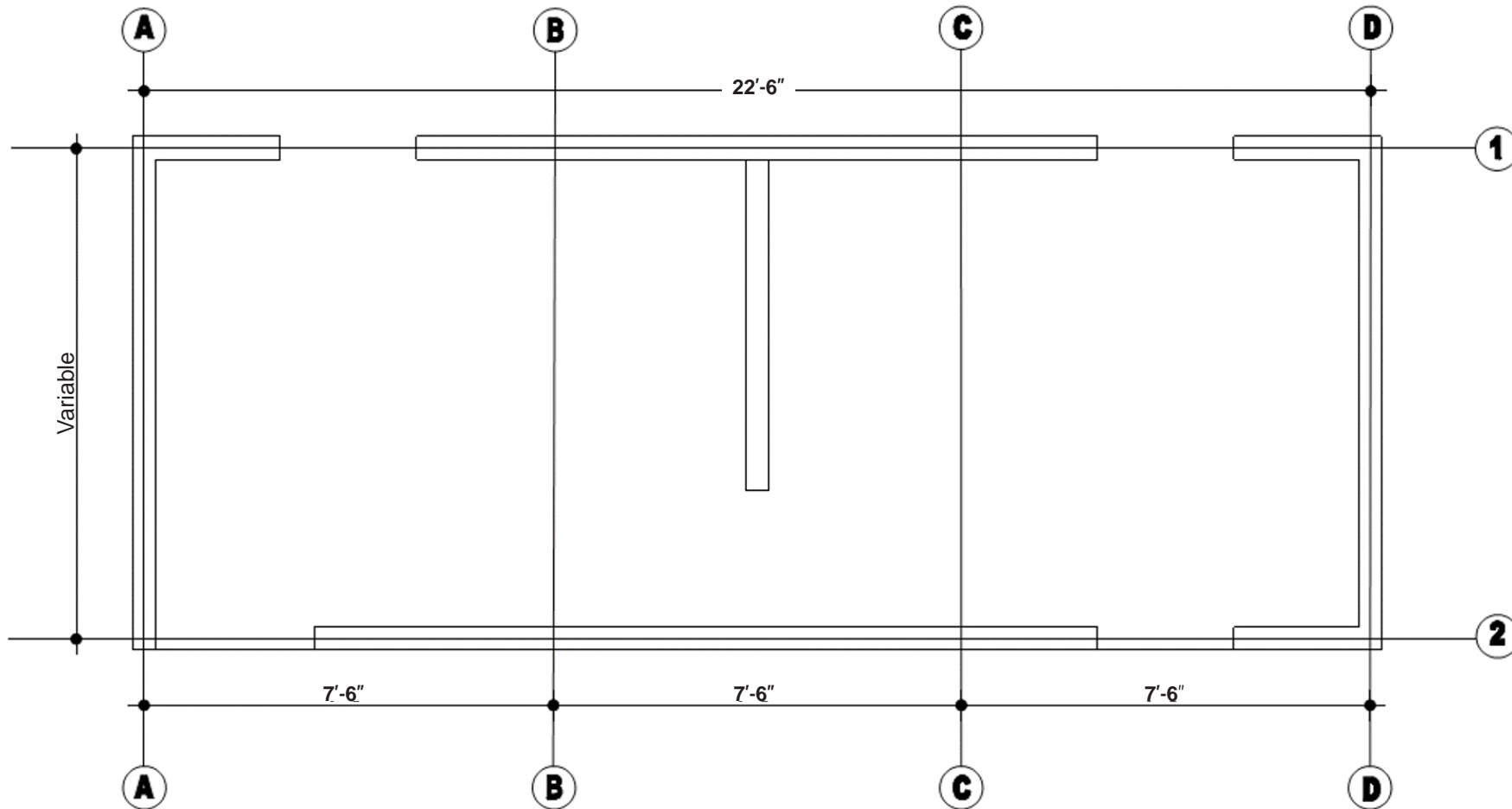

## FERROCEMENT L- PANEL

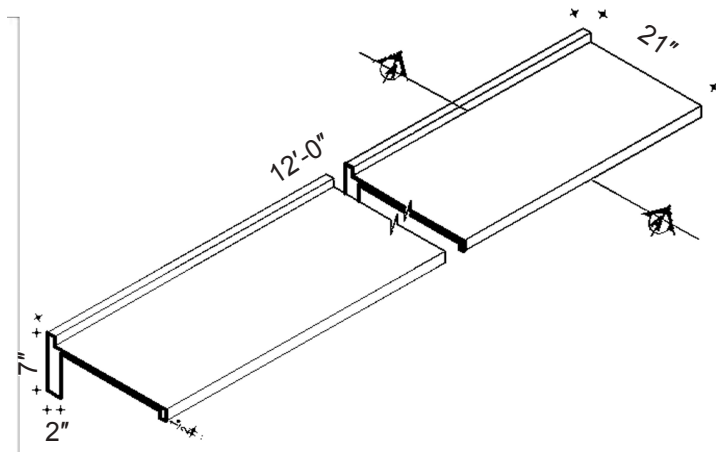

Isometric View

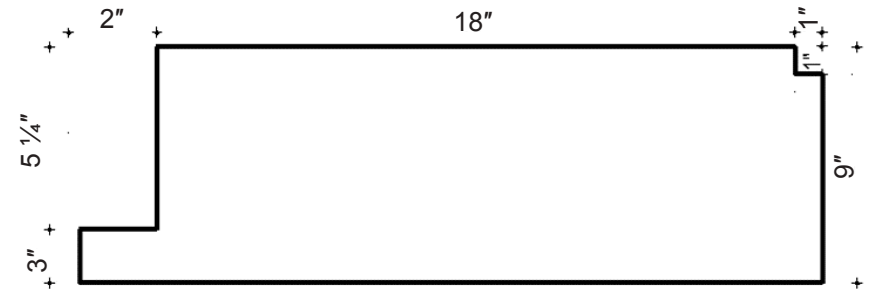

Section of L-panel mould

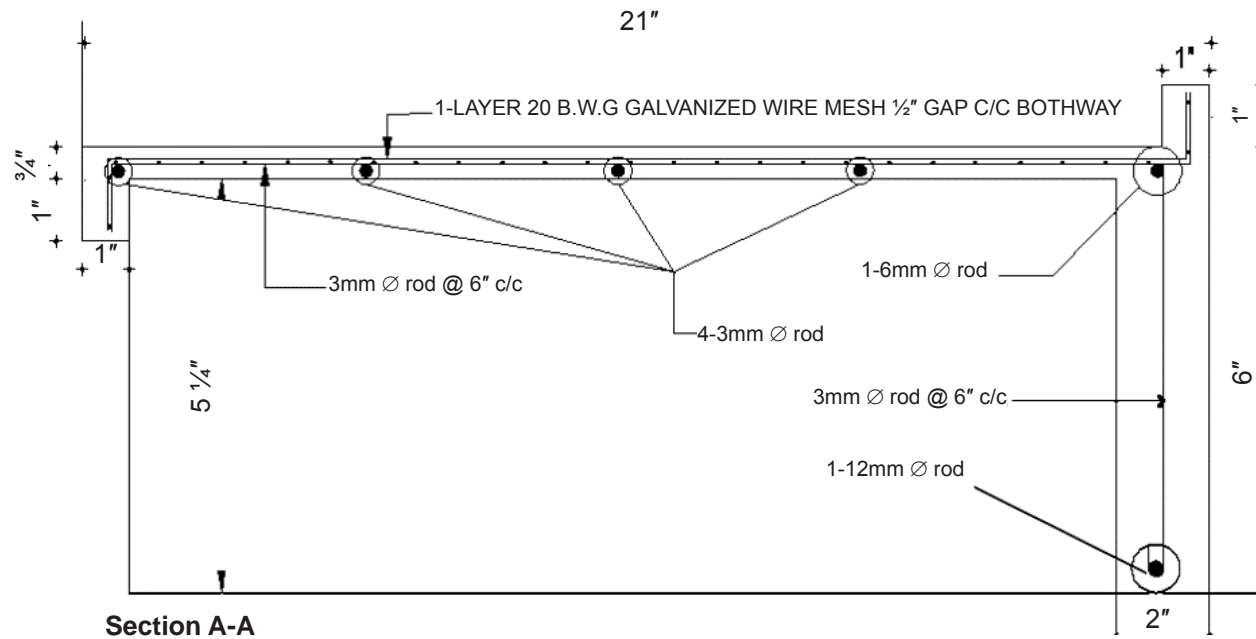

Section A-A



## F.C U-CHANNEL

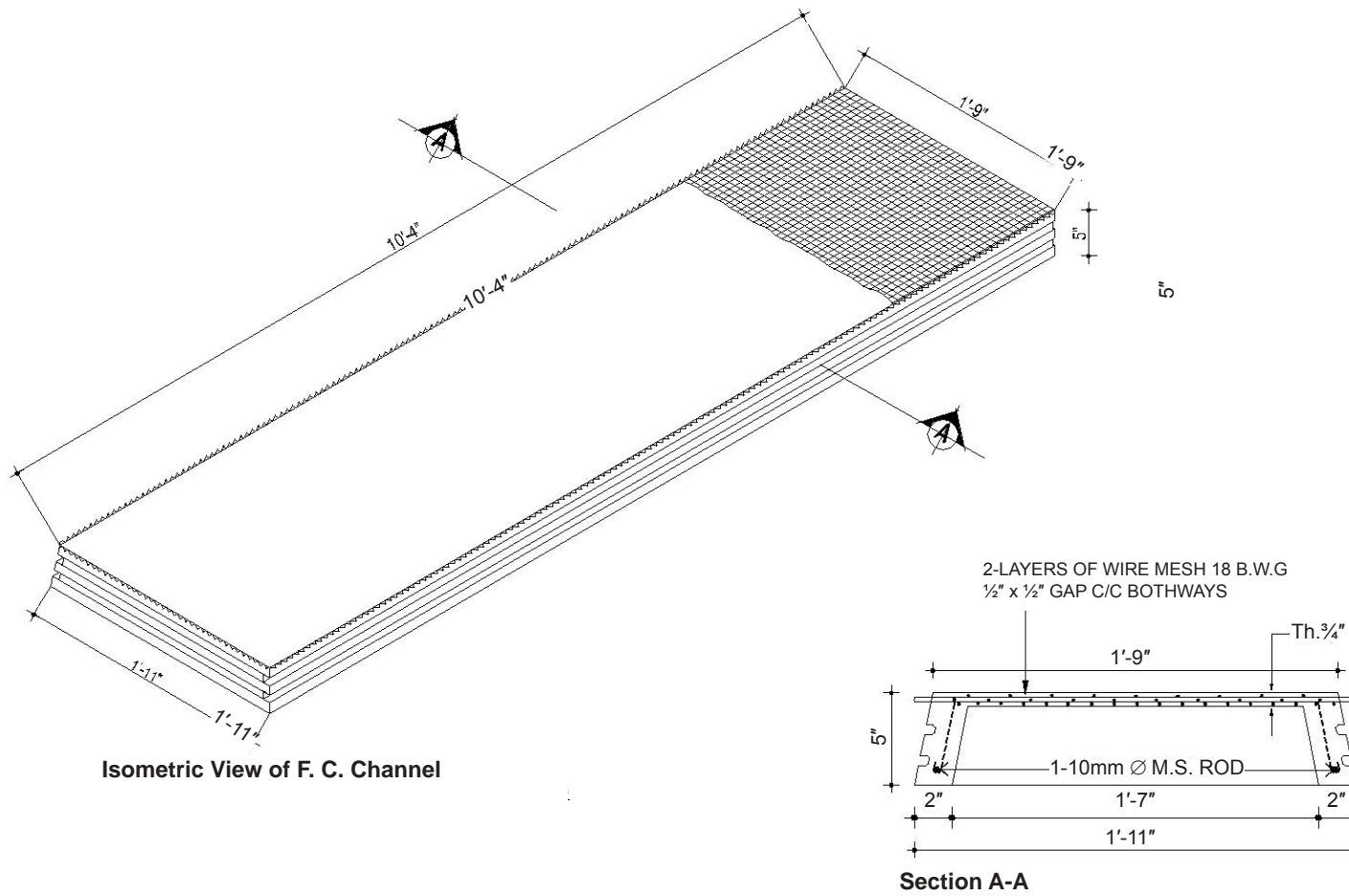

## F.C CURRUGATED SHEET

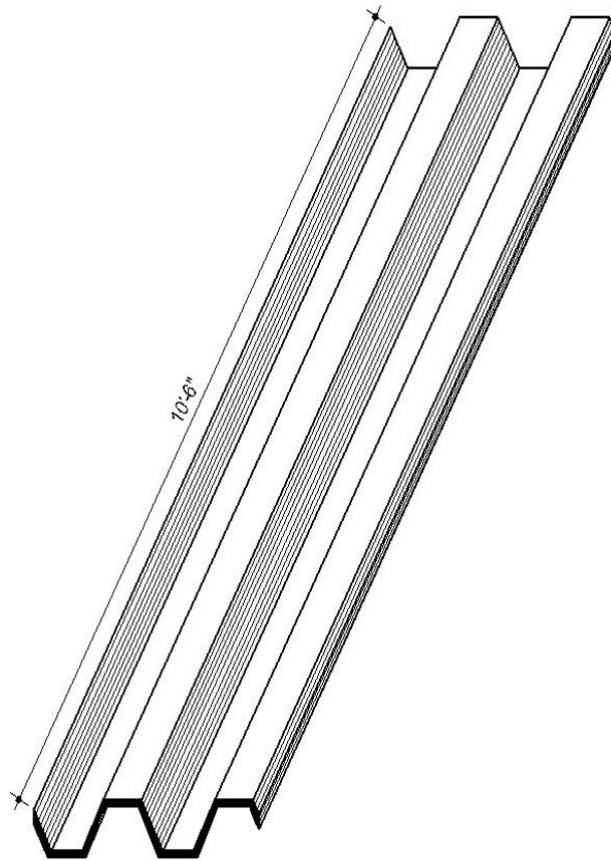

ISOMETRIC VIEW OF F.C. CURRUGATED SHEET

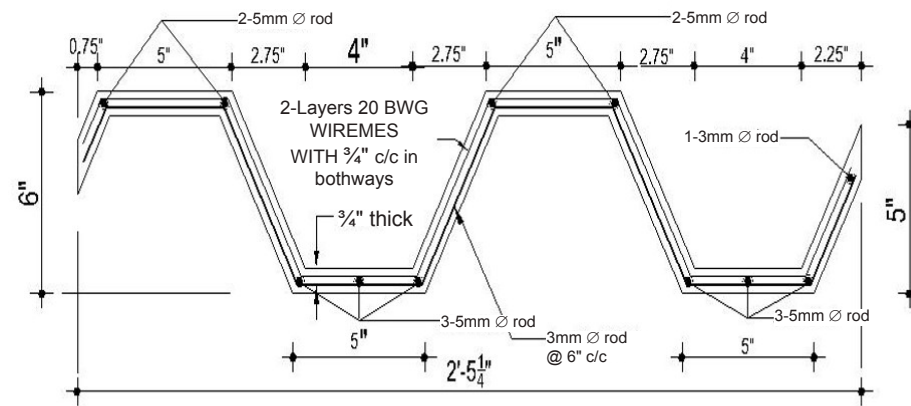

CROSS SEC. OF F.C. CURRUGATED SHEET DETAILS

## 3.6.2 Load Bearing Structure

### 3.6.2.1 Plan (for Area 2 & Area 3)

#### MODEL 1

The typical house plan is designed considering the local spatial needs. Dimension of the houses can be altered according to the inhabitants preferences considering the structural feasibility.

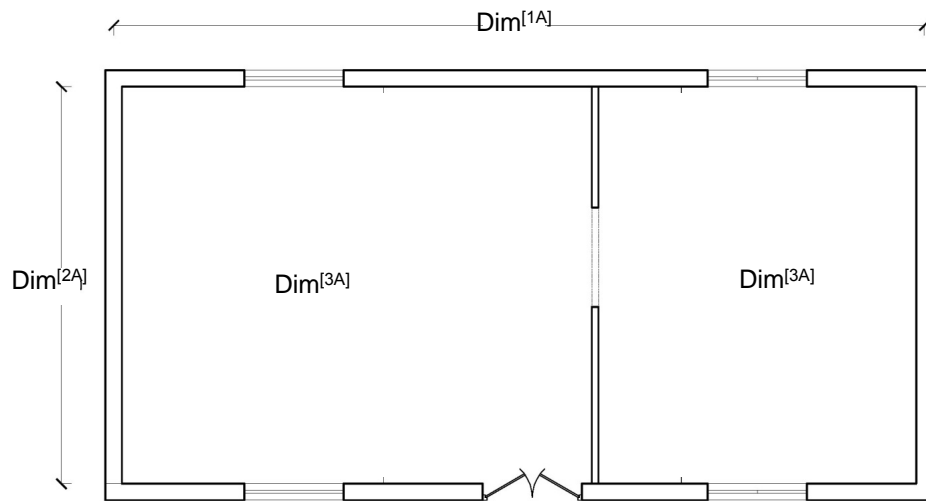

Plan Model 1

#### $Dim^{[1A]}$

Dimension to be adjusted with available building block module and available local measuring unit (e.g. 1 haat= 1'6") but should not be less than 21'-0". Windows should be placed at least 2' from the corner end of the wall

#### $Dim^{[2A]}$

Dimension to be adjusted with available building block module and available local measuring unit but should not be less than 9'-6"

#### $Dim^{[3A]}$

Dimension to be adjusted maintaining standards and local practices

#### MODEL 2

An alternative to model 1 is a single family simple dwelling unit (12'-6"x10'-0") that can be self organized according to inhabitant's need. Construction stages are same as model 1.

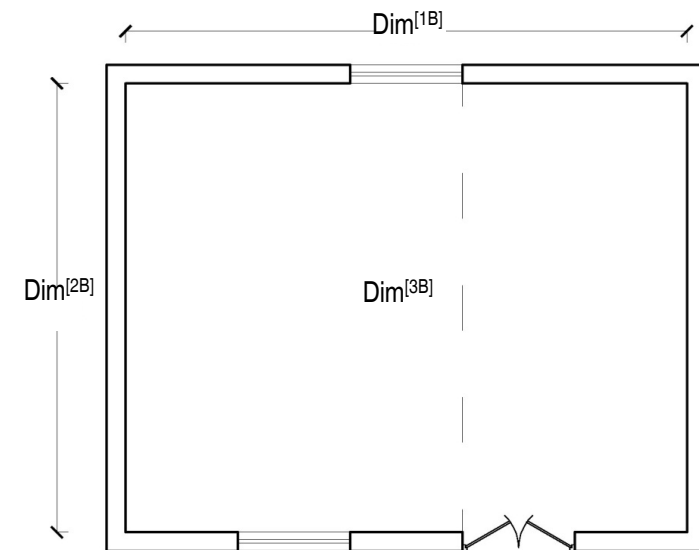

Plan Model 2

#### $Dim^{[1B]}$

Dimension to be adjusted with available building block module and available local measuring unit (e.g. 1 haat= 1'6") but should not be less than 12'-0". Windows should be placed at least 2' from the corner end of the wall

#### $Dim^{[2B]}$

Dimension to be adjusted with available building block module and available local measuring unit but should not be less than 9'-6"

#### $Dim^{[3B]}$

Dimension to be adjusted maintaining standards and local practices

**SECTION OF LOAD BEARING STRUCTURE: MODEL 1**  
 (Area 3 \_without Emergency Escape)

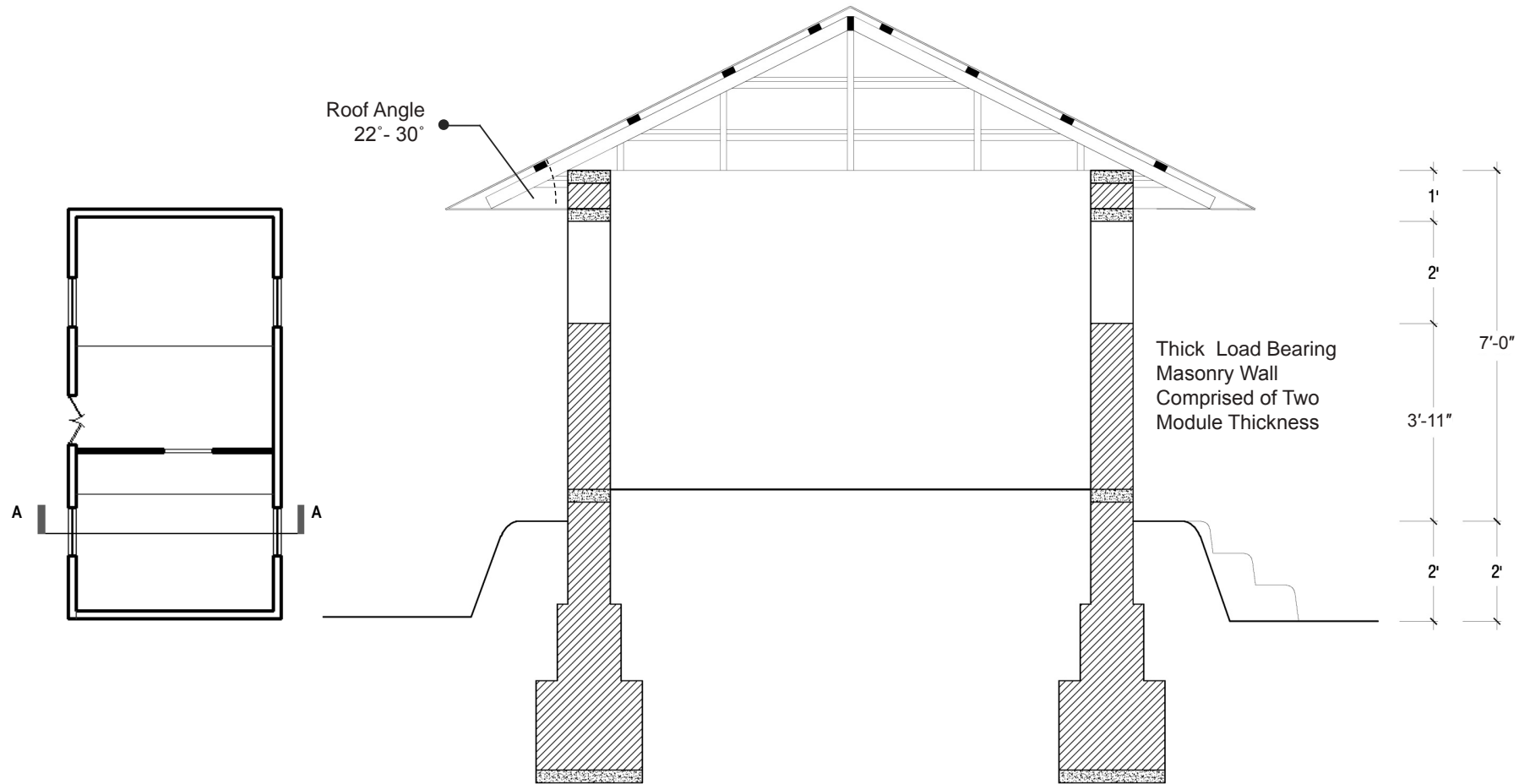

**Section AA**

## SECTION OF LOAD BEARING STRUCTURE: MODEL 1 (Area 2 \_with Emergency Escape)

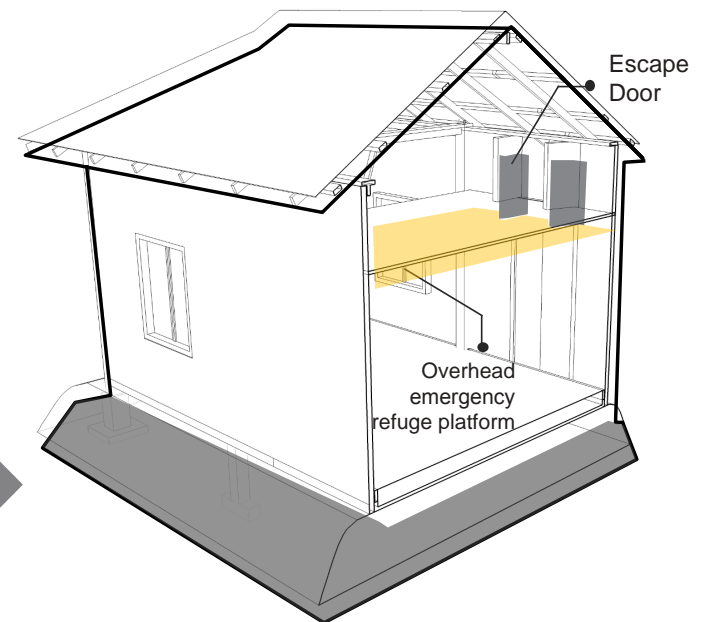
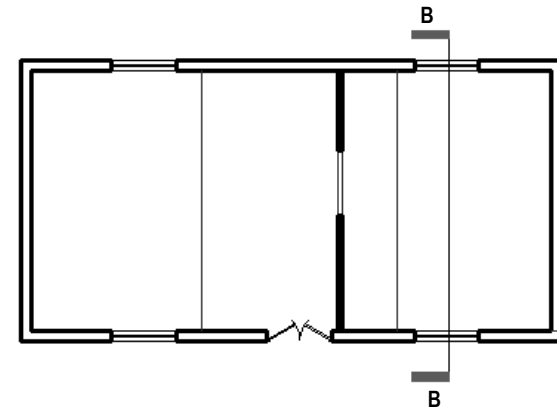
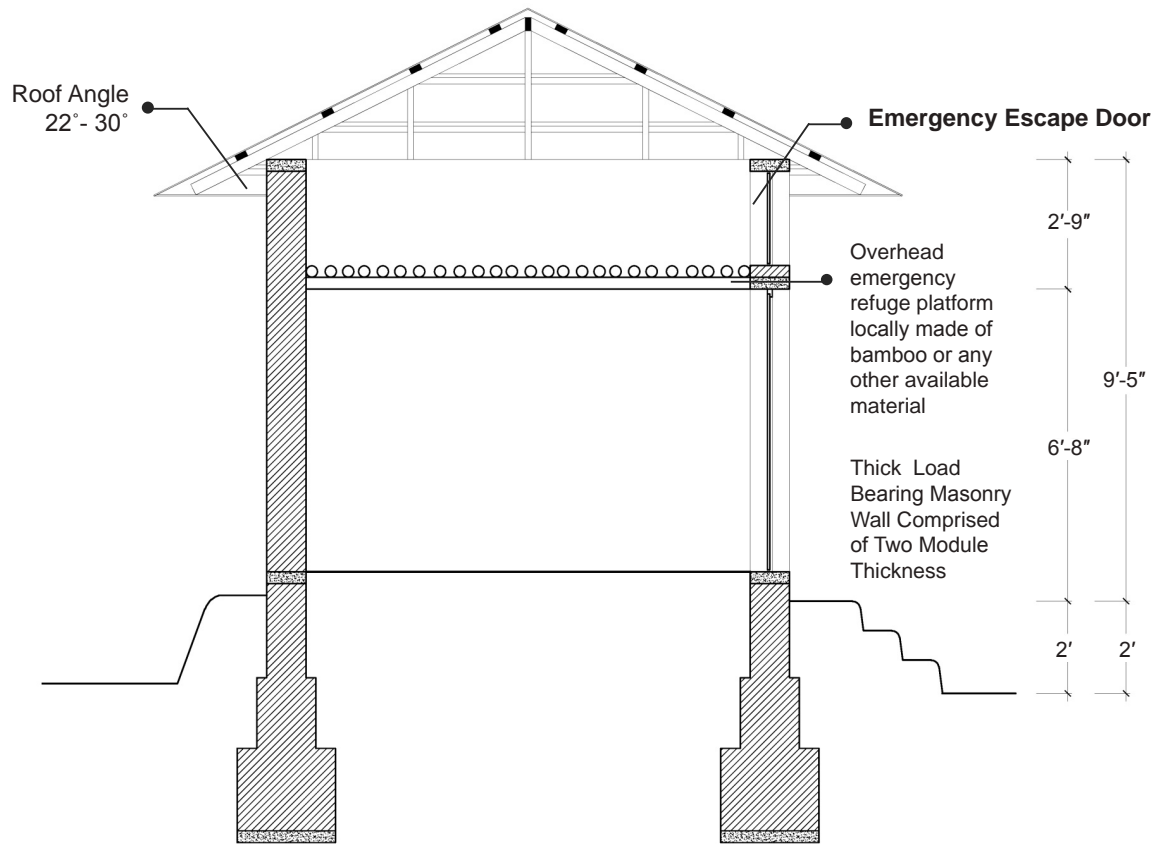

Sectional Perspective showing Emergency Platform with Escape Door

Section BB

**SECTION OF ONE LAYER THICK LOAD BEARING STRUCTURE: MODEL 1**

(Area 2 \_with Emergency Escape)

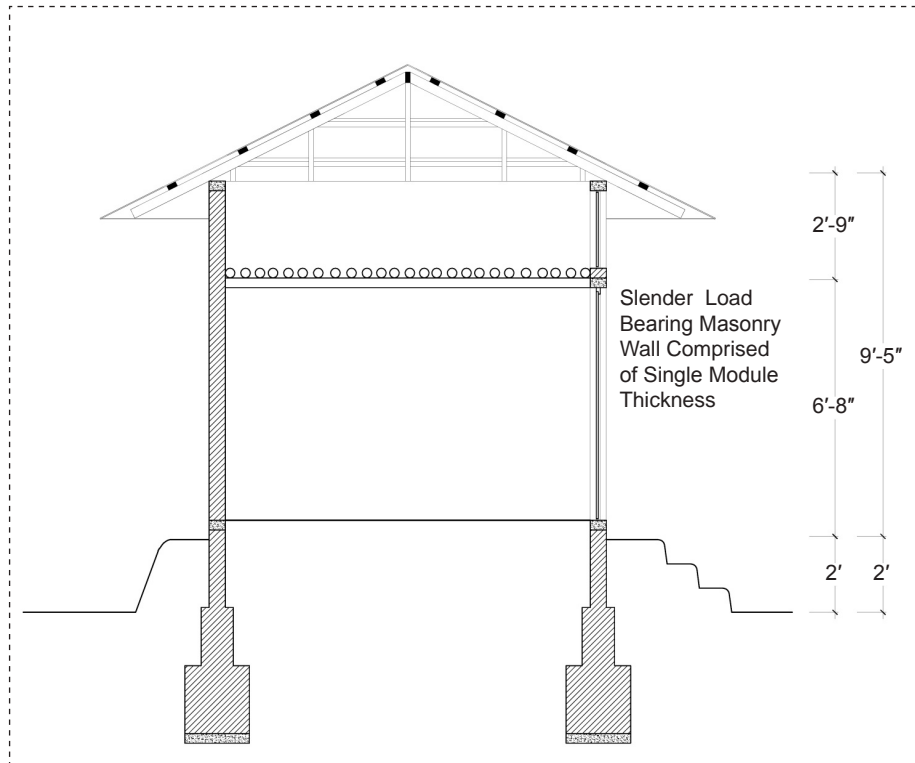

**SECTION OF ONE LAYER THICK LOAD BEARING STRUCTURE: MODEL 1**

(Area 3 \_without Emergency Escape)

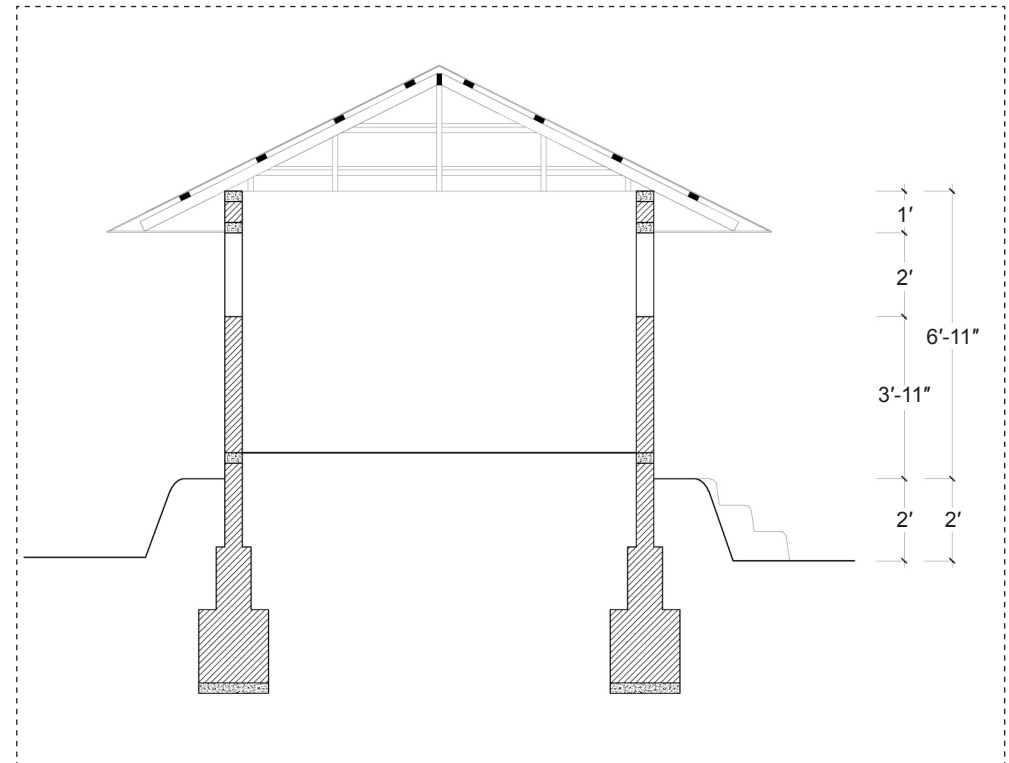



## ELEVATION



**Front Elevation with Escape Door  
For Area 2 & 3**



**Front Elevation without Escape Door  
For Area 3**

## FORMATION OF HOUSE MODULE

(Model 1: for Area 2; for Area 3 the same construction process will be followed)

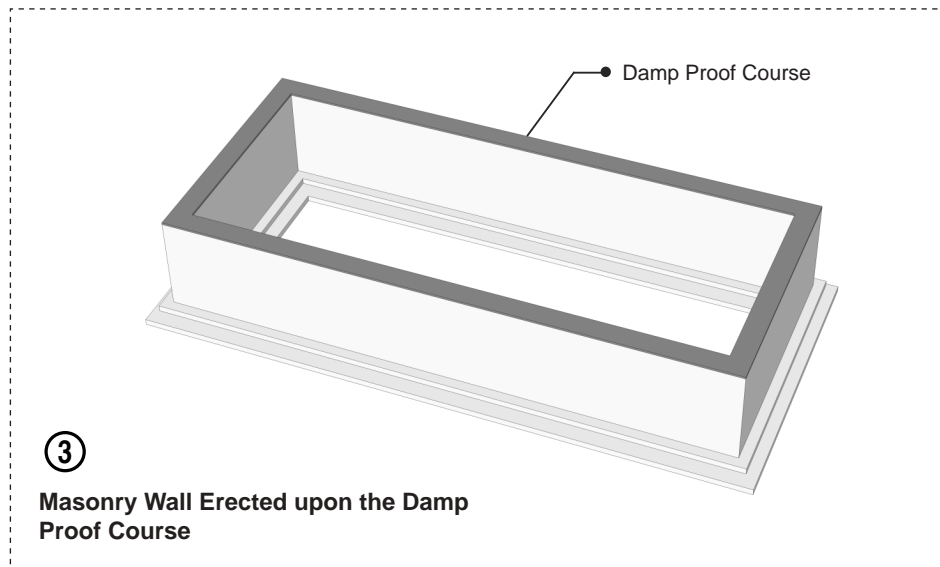
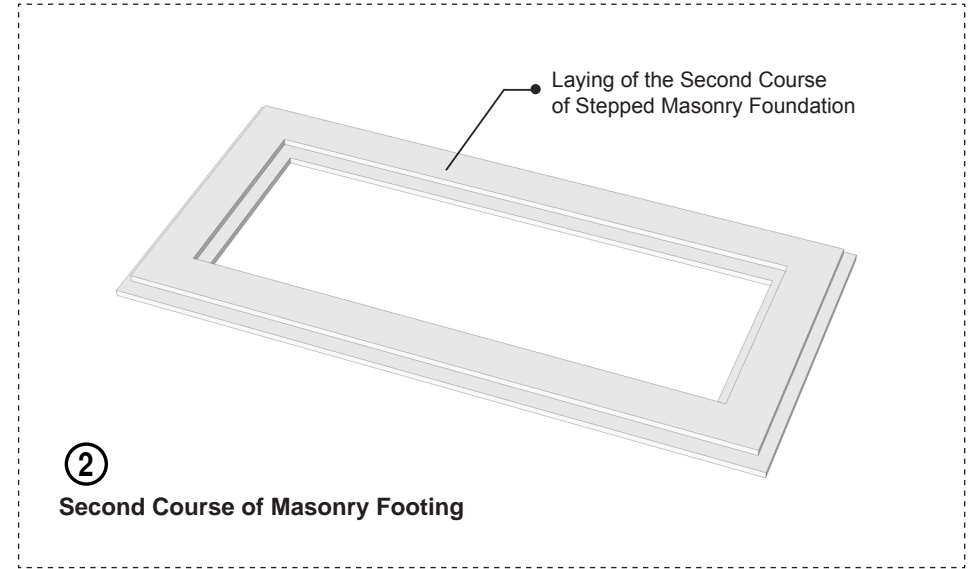
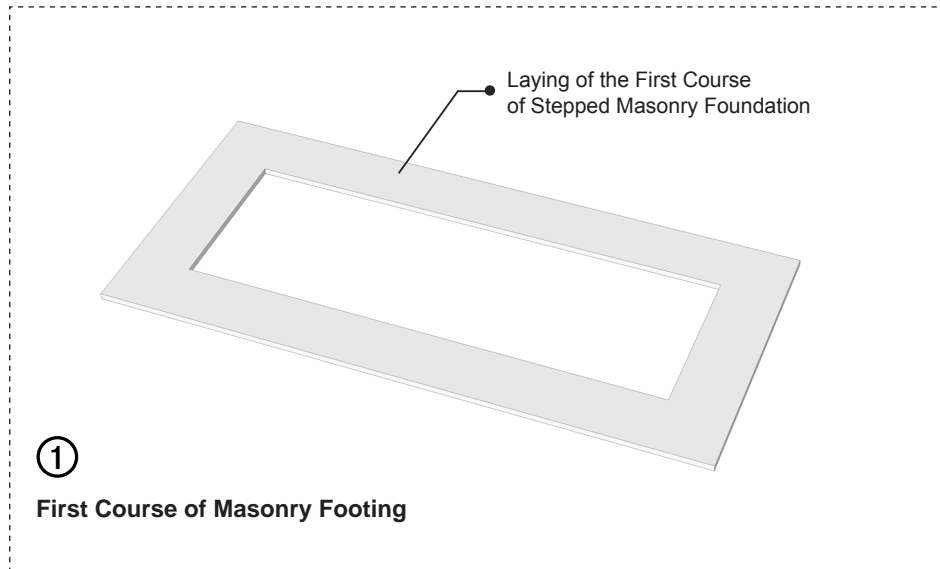

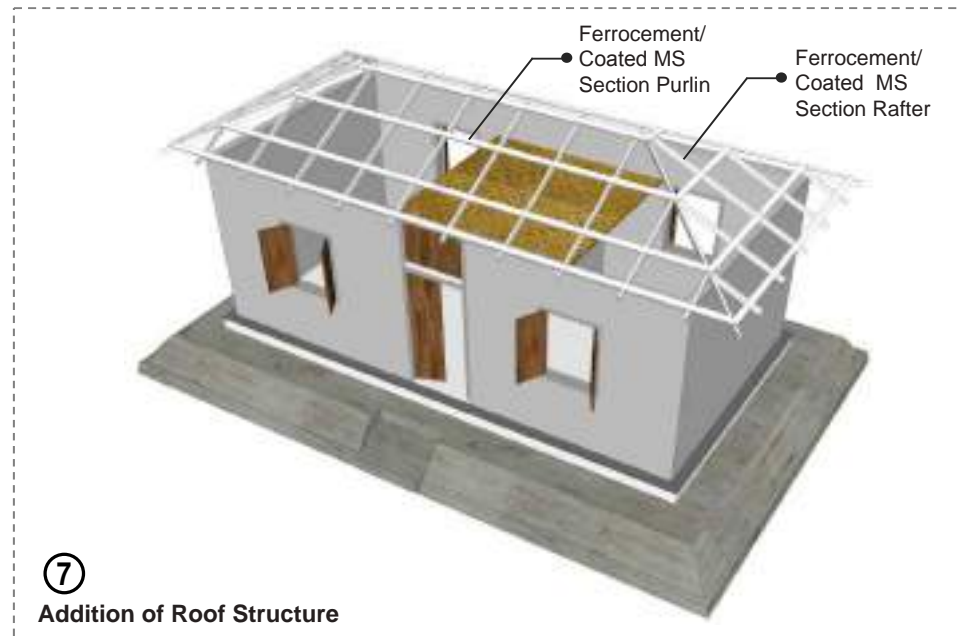
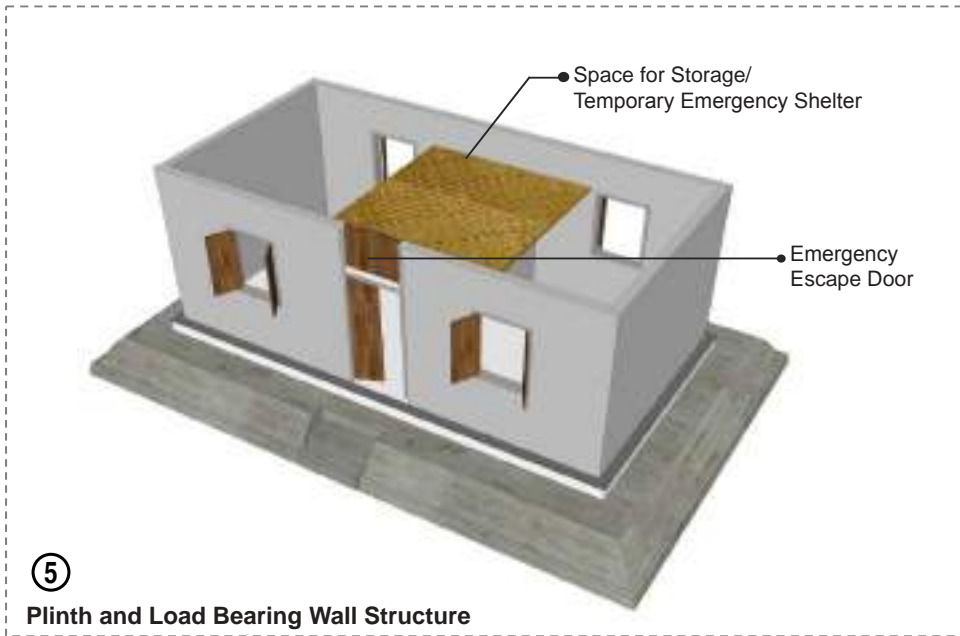



9

Complete Built Form with Gable (Dochala) Roof for Area 2

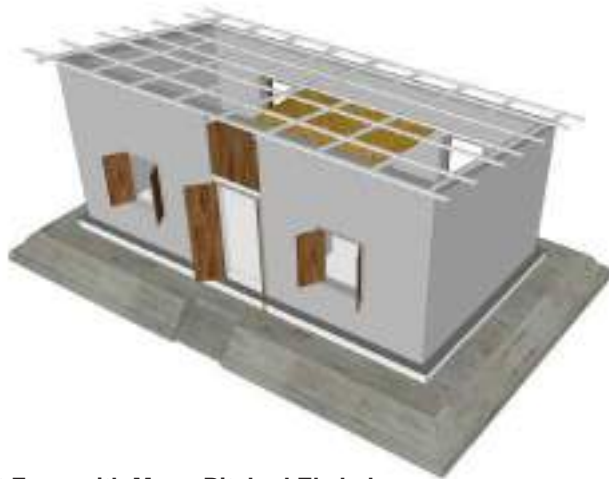

10

Complete Built Form with Mono Pitched Ekchala Roof for Area 2



**Model 1\_Area 2**



House form with Hipped Roof  
(with Emergency Escape)



House form with Gable Roof  
(with Emergency Escape)



House form with Mono  
Pitched Roof  
(with Emergency Escape)

**Model 1\_Area 3**



House form with Hipped  
Roof (without Emergency  
Escape)



House form with Gable  
Roof (without Emergency  
Escape)



House form with Mono  
Pitched Roof  
(with Emergency Escape)



**Model 2\_Area 2**



◀ House form with Hipped Roof  
(with Emergency Escape)



◀ House form with Gable Roof  
(with Emergency Escape)



◀ House form with Mono Pitched Roof  
(with Emergency Escape)

**Model 2\_Area 3**



◀ House form with Hipped Roof  
(without Emergency Escape)



◀ House form with Gable Roof  
(without Emergency Escape)



◀ House form with Mono Pitched Roof  
(without Emergency Escape)



### 3.6.2.2 Wall Elements



CSEB



Interlocking CSEB Block



4" Sand Cement Hollow Block



3D Panel



Sandwich Panel



CLC Block

**Note:** The given material options are suitable as load bearing materials.

### 3.6.1.2C Roofing Elements

For roofing elements see (Chapter 2: Design for Coastal Area, section 2.6.2.3C Roofing Elements).



### 3.7 DESIGN RATIONALE

These geographical landscapes are of much transient nature and experience seasonal inundation of available land area in forms of varying degree of monsoon floods. The char lands are mostly government properties and also often undergoes geographical phenomena of erosion and formation. Other flood plains also present forms of physical conditions. Some areas can experience both river erosion and flooding while others can

just face periodical flooding; regular or severe. Some areas might hardly be affected by occurring floods due to raised island-mounds. Such complex conditions have been simplified by categorizing design intervention task for three areas of particular properties. House models of both larger and minute different dimensions have been proposed; once again to address both the issues of permanency, geographical transiency and rehabilitation-relocation

issues. Load bearing house models have been proposed for non-erosive grounds. Where severe flood occurrence is extended, an extra refuge space in form of lofted volume overhead along with a small exit door has been proposed. The overhead refuge platform has been expected to get locally built though.

## CHAPTER FOUR

# DESIGN FOR HAOR AREAS

### 4.1 GEOGRAPHIC PROFILE

Geographic condition of Haor is different from other lands with an enriched stock of biodiversity. The haor are vast stretches of land that are submerged under water during rainy season, which appears like a sea half of the year and mostly dry during winter. Such seasonal shifts expose rich alluvial soil of enhanced fertility. Strong wave actions during monsoon season causes formidable land erosion around high ground areas. These regions are highly influenced by the hydrological profile of surrounding river basin areas; therefore seasonal flooding of varying degrees are a general annual natural phenomena.

### 4.2 CLIMATIC FACTORS FOR DESIGN CONSIDERATIONS

- ▶ Flash Flood
- ▶ Nor westerly, Tornado
- ▶ Windy Waves (Afal)
- ▶ Embankment Erosion
- ▶ Monsoon Flooding

- ▶ Humidity
- ▶ Northern Winter Wind

### 4.3 HAZARD PROFILE

Haor inhabitants are constantly at risk of major flooding. The normal level of water in rainy season causes considerable damage every year on the edge of the islands which are continually at risk of having their land inundated and eroded and subsequently being displaced. In some severe season the level of water during flood can reach 1.5 m above the level of the floor of the houses, causing significant displacement. Flash flood, Tornado and Afal are some other major impactful natural phenomena in this area.

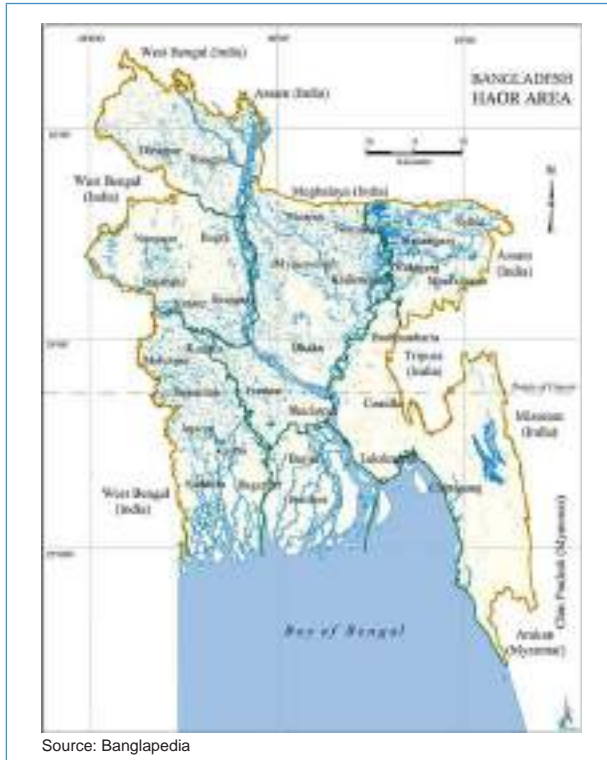

Source: Banglapedia





## 4.4 PREVAILING PRACTICES

### Local Practices

- ▶ Local self-built houses are mostly single storied and hipped roofed type.
- ▶ RCC post and metal/wooden frames are dominant in structure.
- ▶ CGI/plain metal sheets are used as wall and roofing material.
- ▶ Windows are absent in most of the houses.
- ▶ Maximum plinths are kutcha.
- ▶ Bamboo mats/ tarpaulins are used under roofs in order to mitigate the heating.

### Introduced Housing by Different GOs and NGOs

- ▶ Gable and hipped both type of roof commonly used in this area
- ▶ Communal raised plinth is a common feature.
- ▶ CGI sheet is the most used building material for roofing and walling.
- ▶ Use of bamboo mat as walling material and thatch as roofing can be seen in some houses.
- ▶ Bamboo/RCC post both are used as structural element.

### Community Feedback:

- ▶ No thatched wall due to unavailability of the material and durability, climatic as well as fire protection issues.

- ▶ Service provision must be added with houses.
- ▶ The wind flow in Haor area is a matter of concern, stable structure should be used.
- ▶ Plinth should be stable and CI sheet should be used upon 5' brick wall to protect CI sheet from corrosion.
- ▶ Stones can be used to protect raised homestead.
- ▶ Bamboo is costly, CI sheet is more popular.
- ▶ Tornado is a major problem in some areas of haor basin, CI sheet should be used with proper angle in the roof.
- ▶ Frame structure should be used.
- ▶ To protect slope after every year erosion a cost effective solution is needed like protection with VETIVAR grass.

### Issues Identified

- ▶ Durable structural members concerning issue of longer house lifespan.
- ▶ Structural members to be fastened to each other properly.
- ▶ Additional structural stability to be ensured by the means of introducing bracing elements at due strategic points.
- ▶ Mound raising should be undertaken to establish new settlements.



Thatch roof



Ecor with mud



Bamboo



Wood



CGI sheet



Vegetation for Plinth protection



Barak house at "president palli"



Kacca house at "Hail haor"

## 4.5 BUILDING TYPOLOGY

### 4.5.1 Frame Structure

#### 4.5.1.1 Plan

The plan and physical formation of the proposed model house at Haor area resembles much of that

Flood prone zone, however there are few differences that reflect the lifestyle of the Haor inhabitants. The avoidance of exit hatch on top levels, the linear plan with service space at one end and avoidance of the house model for lesser floor area are few of the measures reasoned for the much stable mode of occupancy of the dwellers.

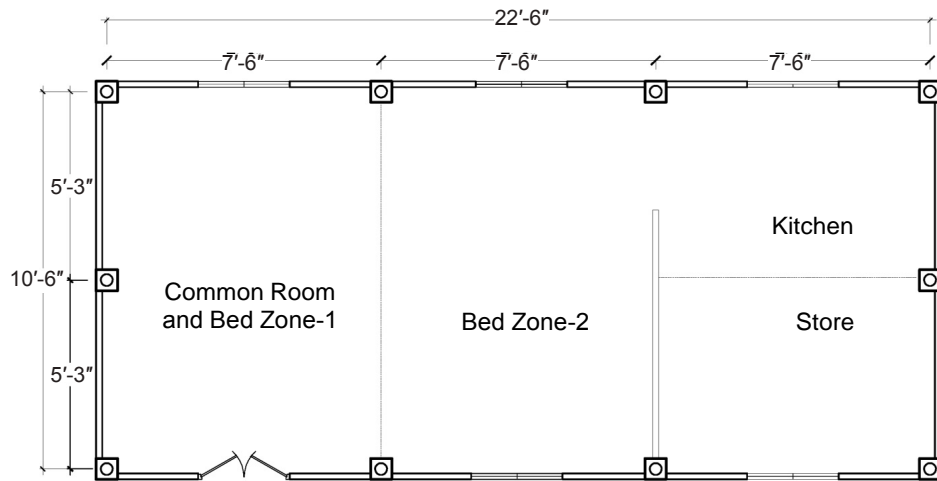

Plan

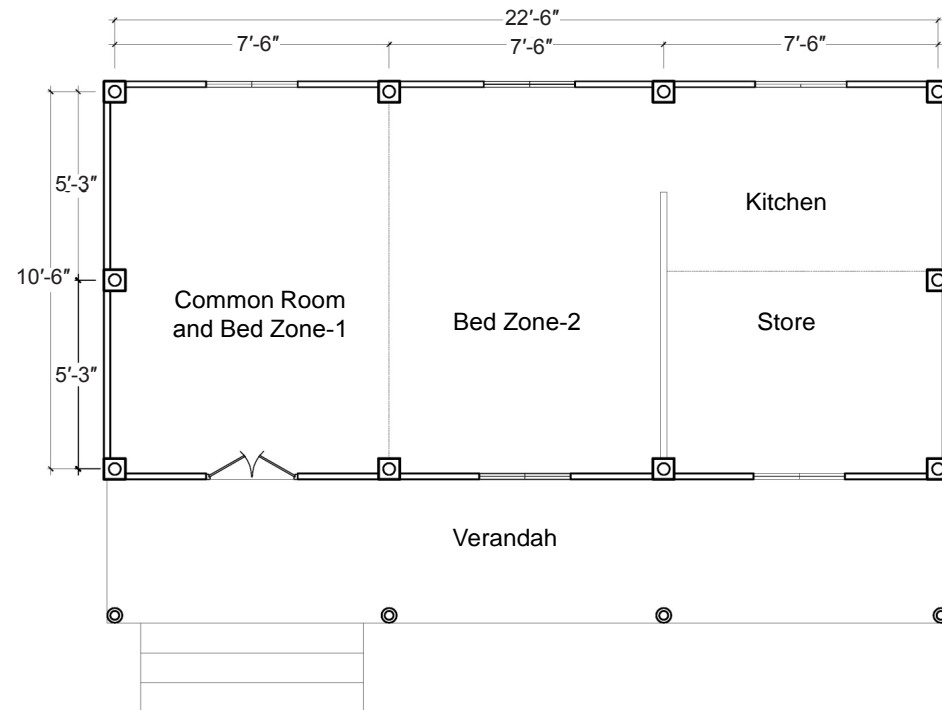

Plan with Additional Verandah

### SECTION OF FRAME STRUCTURE

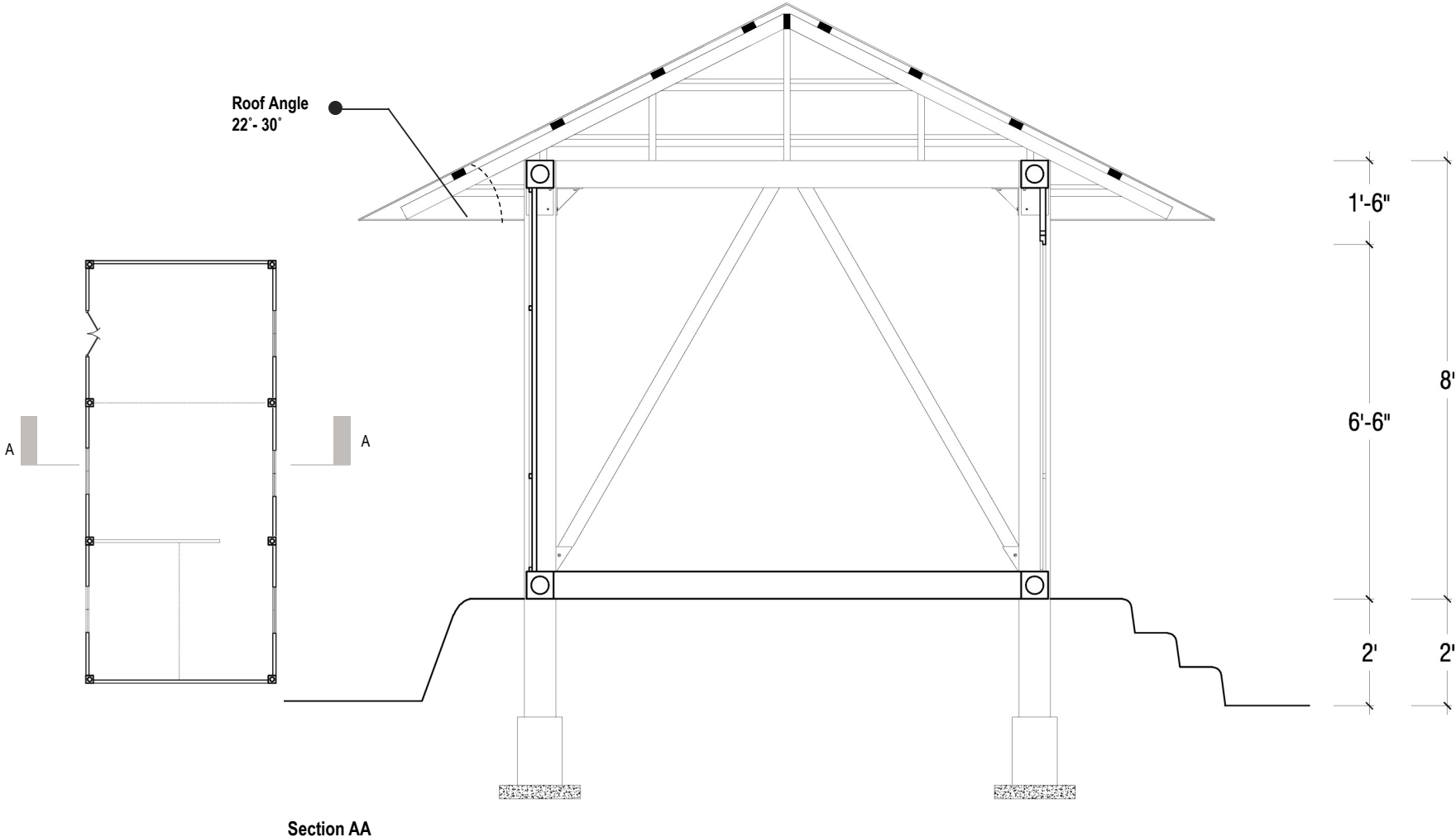



## FORMATION OF HOUSE MODULE

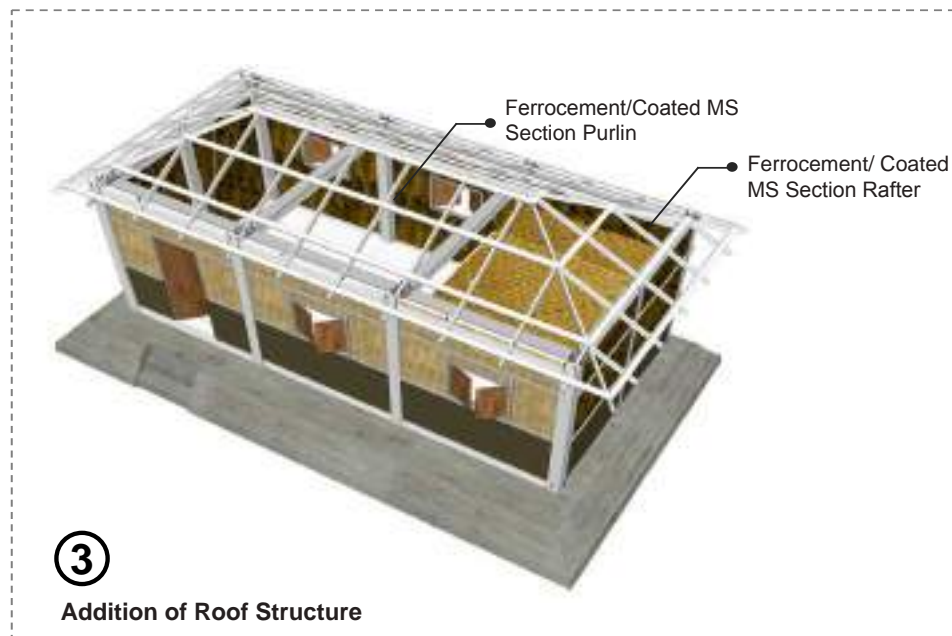
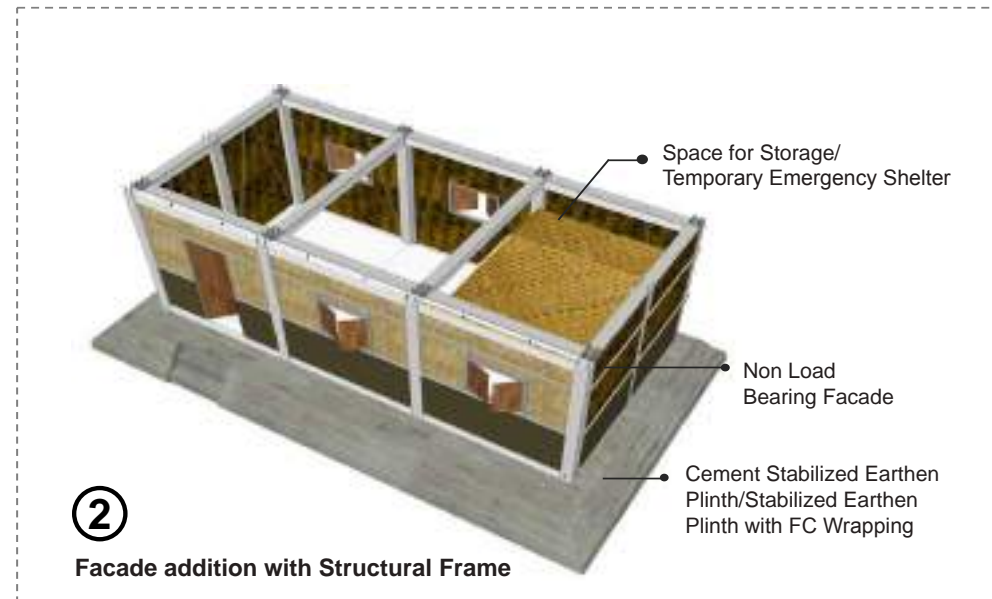
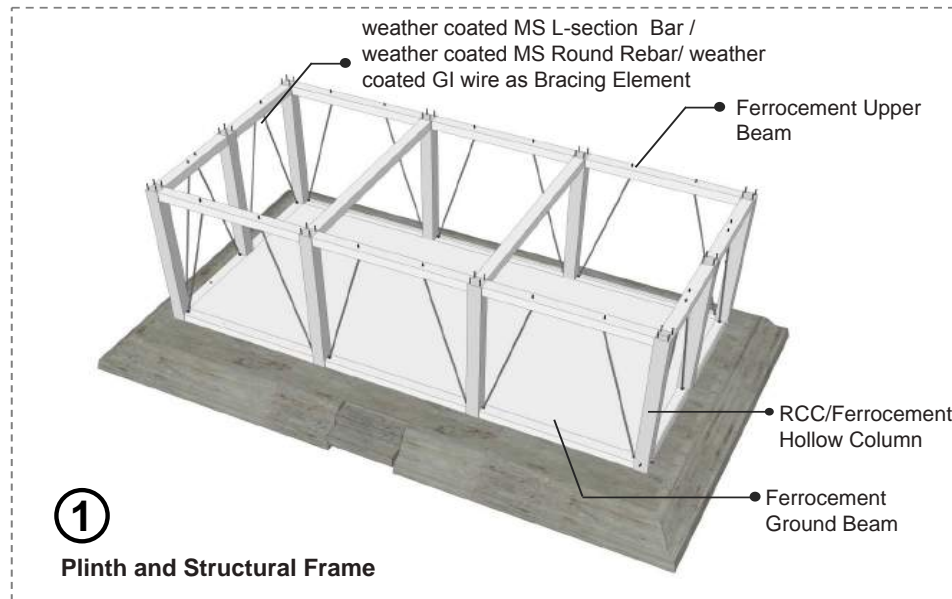

## COMPLETE HOUSE FORM OF FRAME STRUCTURE WITH HIPPED ROOF



## 4.5.2 Load Bearing Structure

The structure could be built on both single leaf wall thickness or double leaf wall thickness

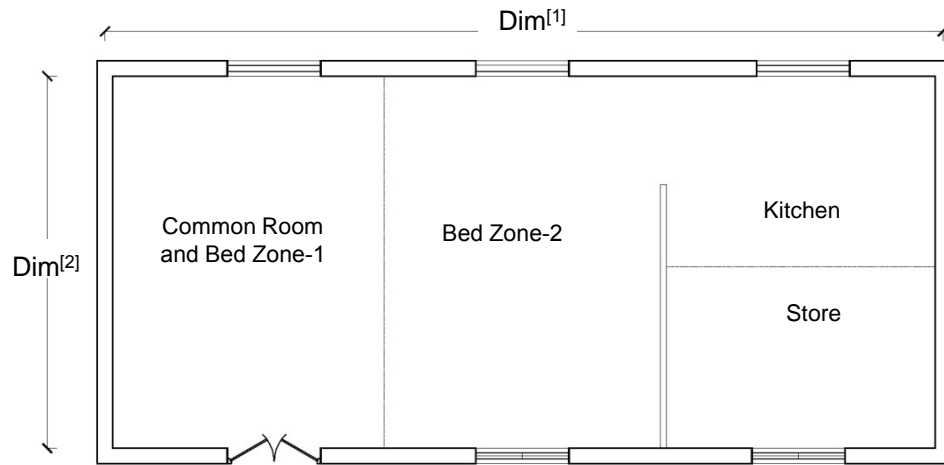

Plan

### Dim[1]

Dimension to be adjusted with available building block module and available local measuring unit ( e.g.1 haat= 1'6") but should not be less than 21'-0"

### Dim[2]

Dimension to be adjusted with available building block module and available local measuring unit but should not be less than 9'-6"



Complete Built Form with Hipped (Chouchala) Roof



Complete Built Form with Gable (Dochala) Roof

### SECTION OF TWO LAYER THICK LOAD BEARING STRUCTURE

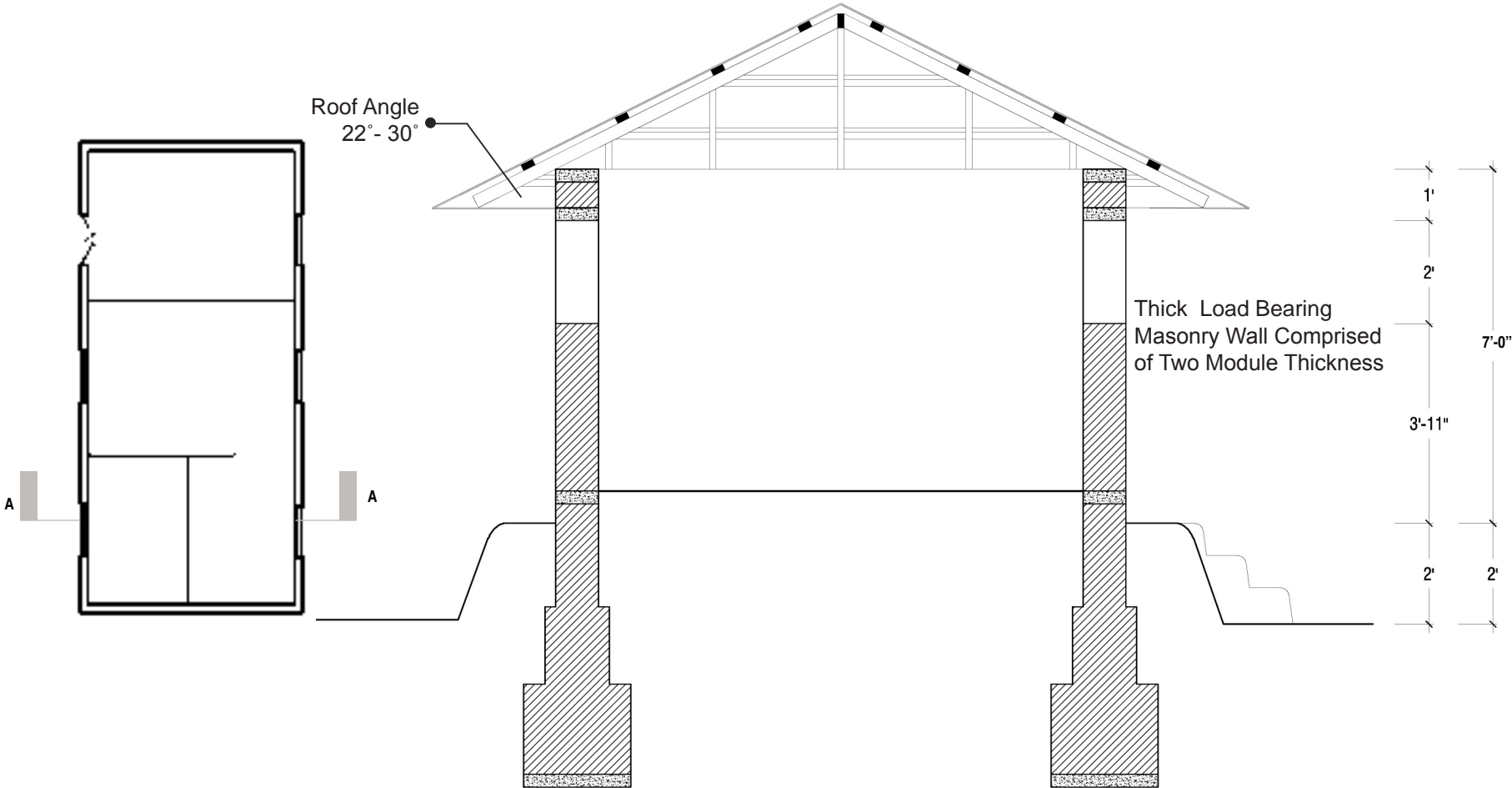

Section AA

## SECTION OF ONE LAYER THICK LOAD BEARING STRUCTURE

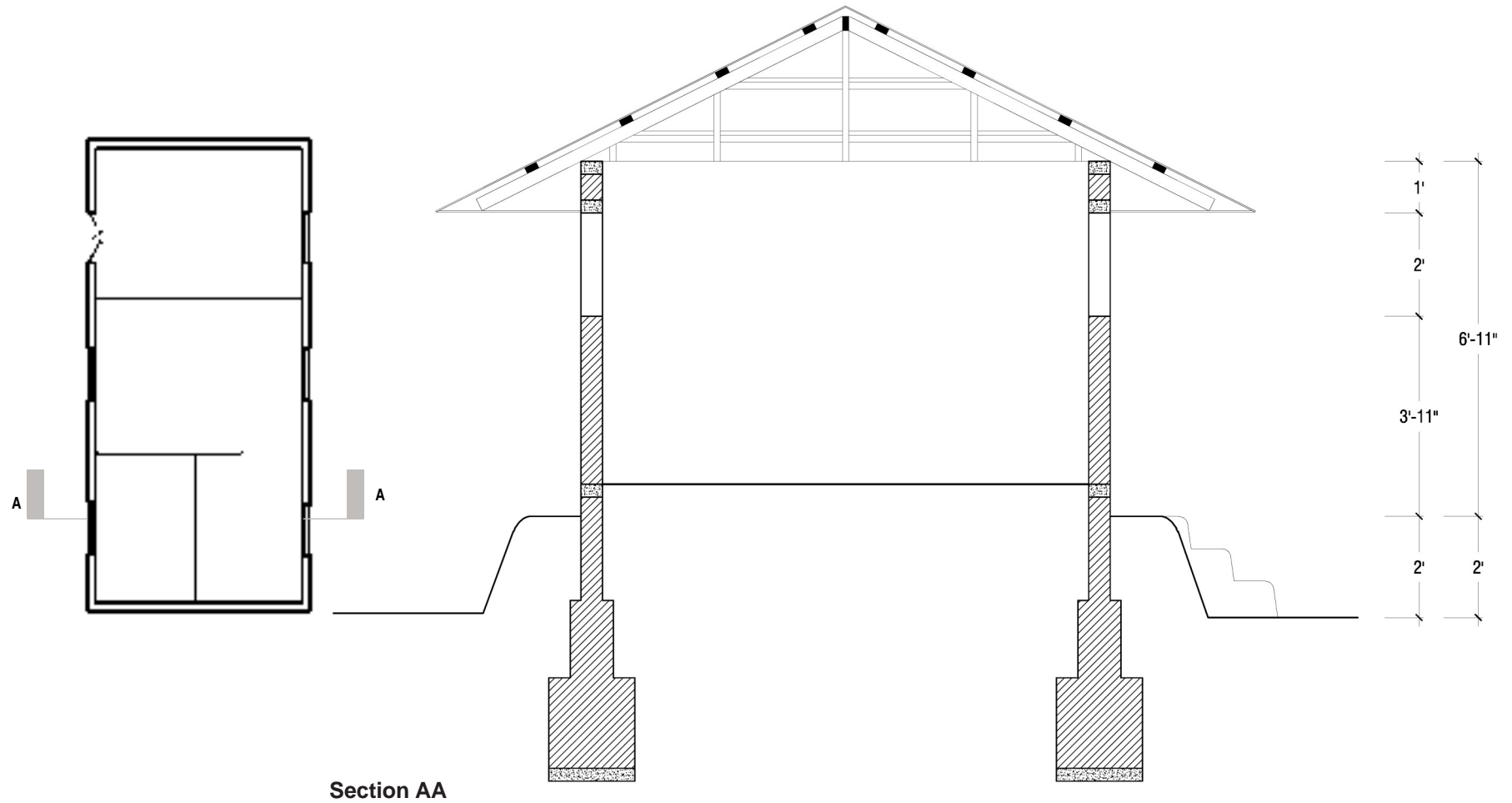

## FORMATION OF HOUSE MODULE

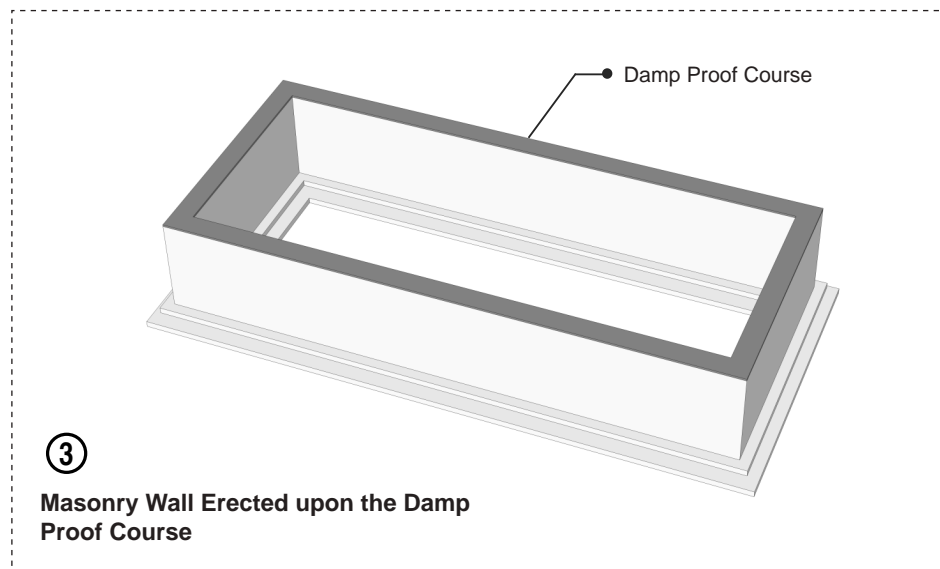
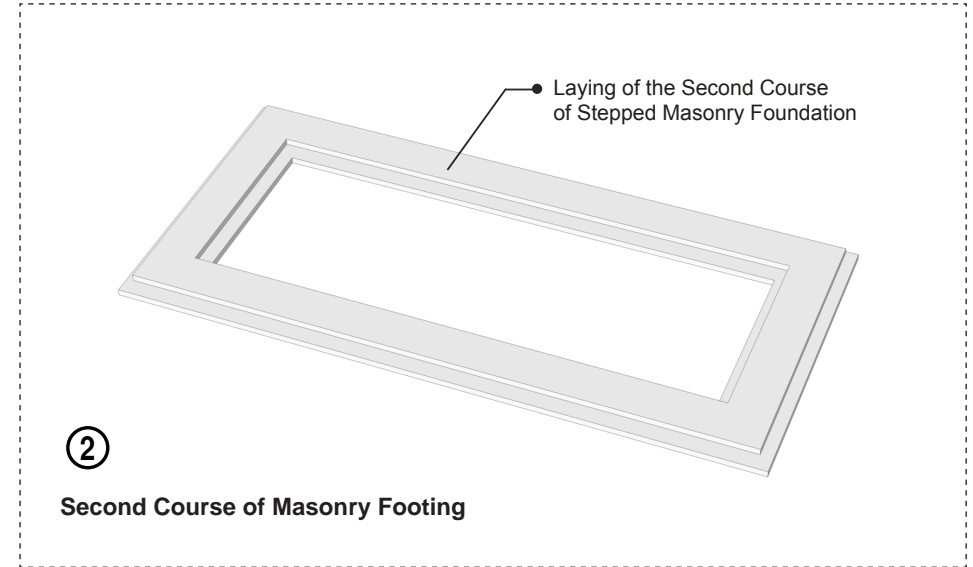
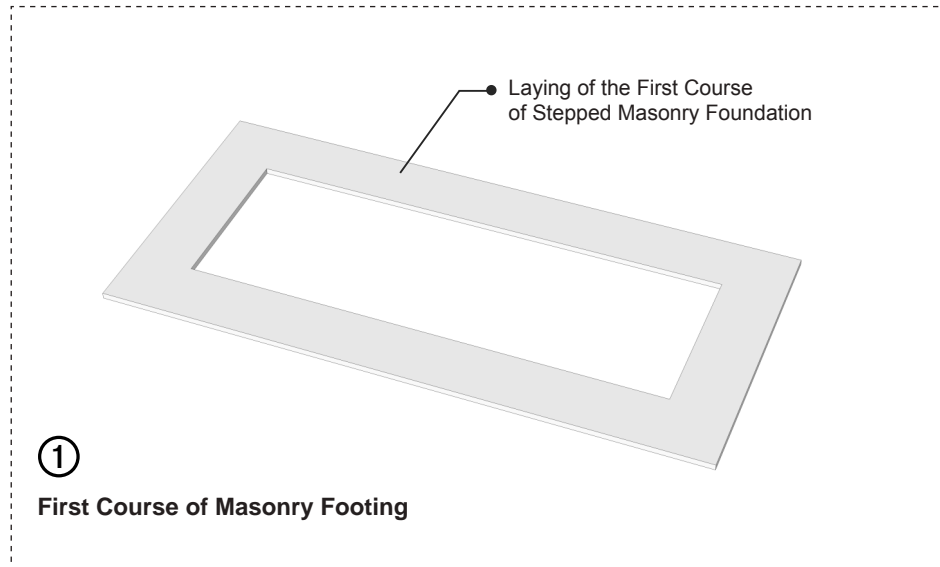



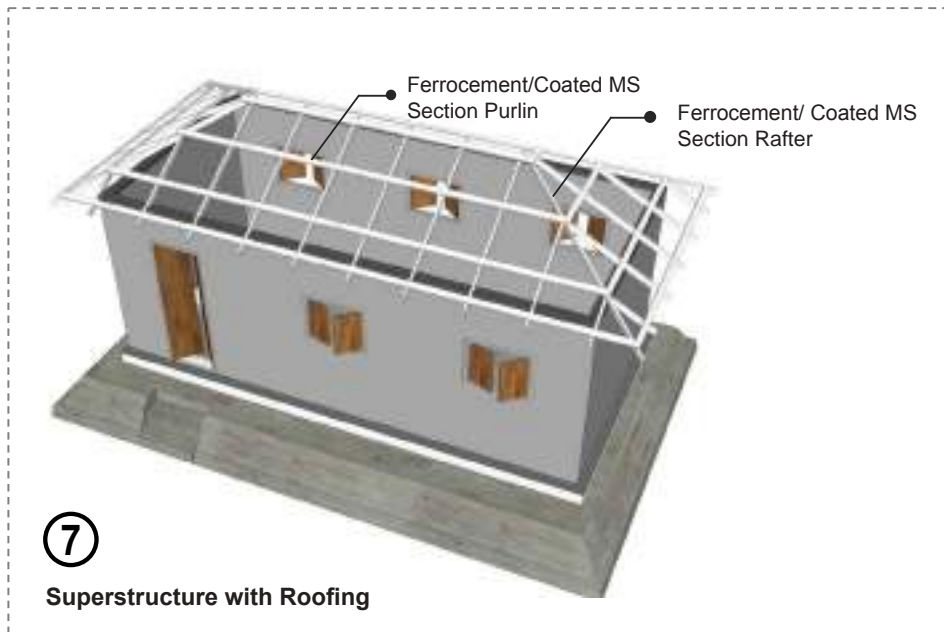
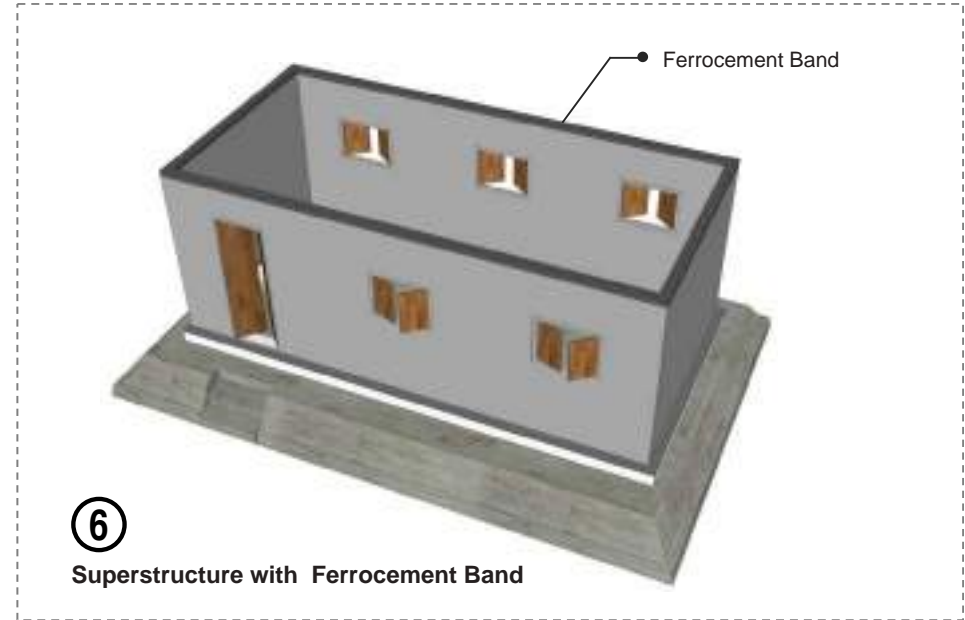
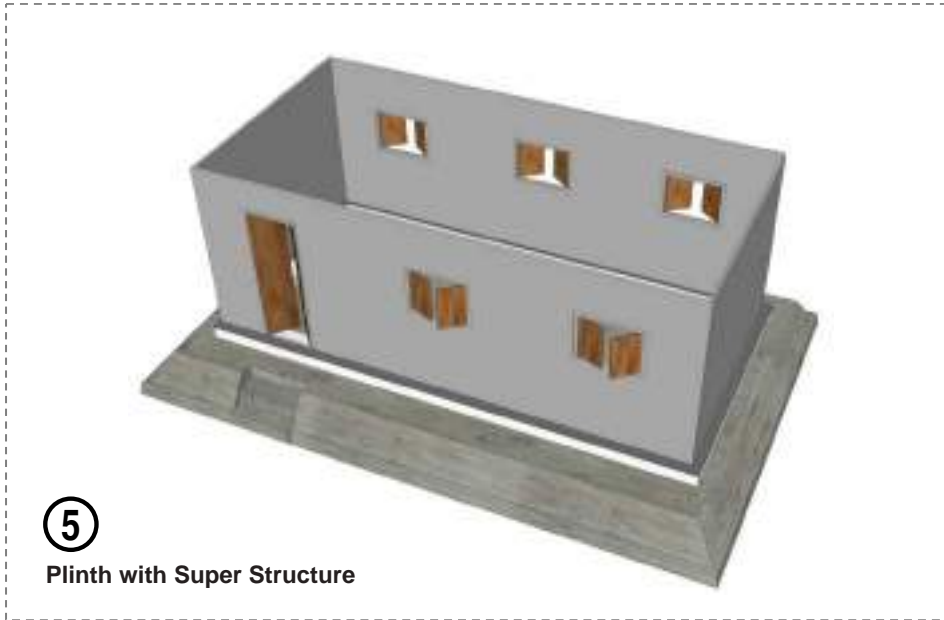

## 4.6 EMBANKMENT (HATI) PROTECTION

Haor habitant builds their house on naturally or artificially elevated mud called “Hati” which is vulnerable during monsoon.

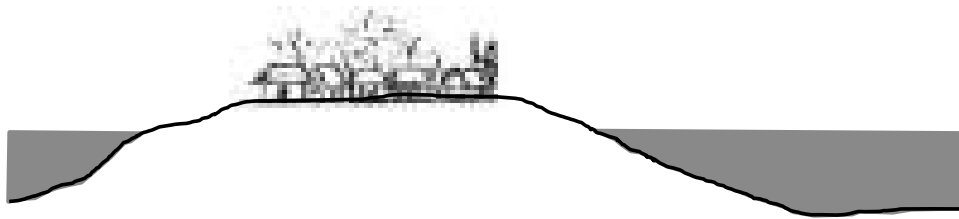

### Regular monsoon condition

Haor inhabitants are constantly at risk of a major flooding. The normal level of water in rainy season causes considerable damage every year. Edge of the Hati are continually at risk of having their land inundated and eroded and subsequently being displaced.

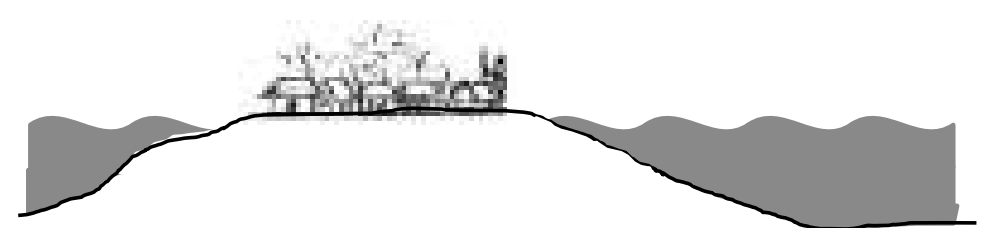

### Wave induced wave impact

During flood water wave created by air and storm which is called Afal. Embankment is being vulnerable due to Afal.

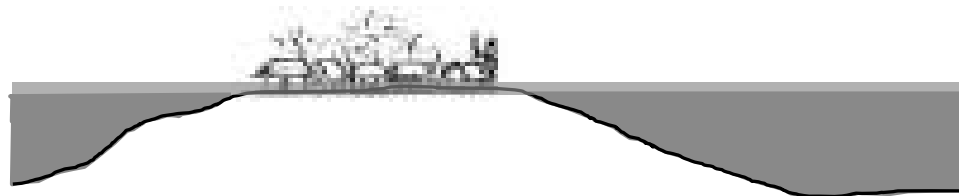

### Flood affected condition

In some severe season the level of water during flood can reach 1.5 m above the level of the floor of the houses, causing significant displacement.

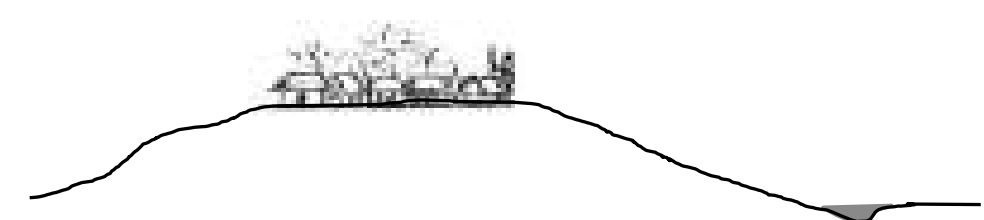

### Dry season condition

During dry winter season inhabitants grow their necessary crops once in a year. Lake like wetlands called ‘Beel’ act as chief source of water during entire dry season.

People who live in the middle of haor need to protect their embankment every year before rainy season when island continuously eroded by wind induced wave action. The various potential measures taken to protect the slopes can broadly be categorized into following three classes:

- ▶ Local practice of slope protection.
- ▶ Conventional engineering measures for slope protection.
- ▶ Ecological engineering measures for slope protection.

#### 4.6.1 Local Practice of Slope protection

- ▶ Locally they use bamboo and grass to protect the embankment which is vulnerable.
- ▶ Some use local stone carpeting to protect the slopes that are prone to frequent wave impacts.
- ▶ The practice of protecting the vulnerable slopes using vegetative cover are often seen among the village community. Some of such potential wetland associated plant species for protecting the embankment slopes are Hijol (*Barringtonia acutangula*), Koroch (*Pongamia pinnata*), Barum (*Crataeva magna*), Chalta (*Dillenia indica*), Latim/ Pithakumra gaachh (*Trewia polycarpa*), Jaam (*Syzygium cumini*), Joggo Dumur (*Ficus glomerata*), Dholkalmi, Murta grass, Binni grass, Chaillya grass, Bamboo etc.



Protection with local stone and bamboo



Bamboo with grass



Protection with retaining walls and stones



Hizol/Koros trees

#### 4.6.2 Conventional Engineering Measures for Slope Protection

- ▶ Most often various forms of concrete slope-stabilization blocks/elements are used to stabilize slope profiles
- ▶ Retaining walls along with buttresses are also deployed to check the occurrence of soil erosion .
- ▶ Earth /sand filled bags are often compiled along the slopes with additional netting above to protect the slopes.



Protection with retaining walls along with buttresses



Earth bag



Concrete slope-stabilization blocks



Protection with retaining wall



### 4.6.3 Ecological Engineering Measures for Slope Protection

- ▶ Wetland associated soil retaining plants/ herbs i.e. grass, Vetiver, Dhol kalmi etc. can be planted on geo carpet( Jute Geo Textile) beds. Grass increases strength of soil from erosion. Vetiver is one kind of “ecological-climax “ grass originated from south India also locally available in Bangladesh can grow easily in any kind of soil like salty , clayey, heavy metal contaminated soil and saline soil. It is found to be effective in up taking heavy metals and removing salinity. Vetiver roots enhance the bearing capacity of both the loose and dense soil. Vetiver grass can prove to be very suitable for slope protection in Bangladesh context in terms of flood, soil erosion, land slide. Source: MS Islam-2015
- ▶ Geo tech bags can also be used along with vegetation mentioned above which is more sustainable than one layer geo carpet.



Vetiver



Slope for Vetiver plantation



Vetiver plantation



Geo bags protection



Locally available vegetation and Geo bags with vegetation

#### 4.6.4 Some other preferable methods of protecting slopes along the Hati edges.

##### 4.6.4.1 Composite method of slope protection

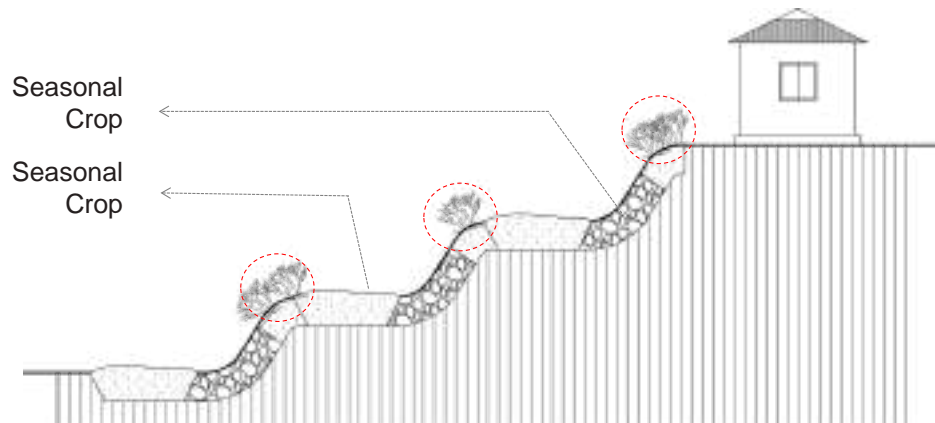

Composite method of slope protection

A scheme comprised of stepped slopes and in between crop plantation on resulting terraces might endow reasonable protection with crop harvest as a bonus gain, the vulnerable angles could be protected with selective stone carpet zones.

##### 4.6.4.2 Riparian vegetation establishment with geo bag/ Ferrocement/RCC block with the scope of growing grass



Perforated Ferrocement block



#### 4.6.4.3 Continuous Earth/Sand Bag with Plaster Covering

Continuous compacted earth bags, connected by barbed wire can protect the edges of “Hat” from wave action.

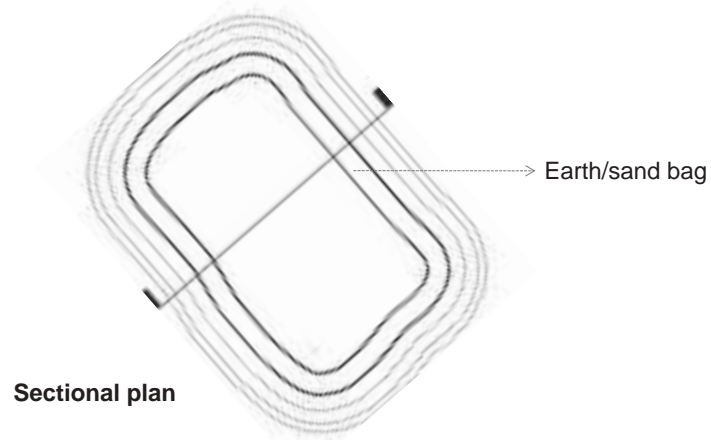

#### 4.6.4.4 Continuous Earth/Sand Bag Trench with Plaster Covering

Vault shaped trenches can be self sustainable structure and can protect embankment from wave action, soil erosion. Plastered wrapping can protect the trench to sustain under water.

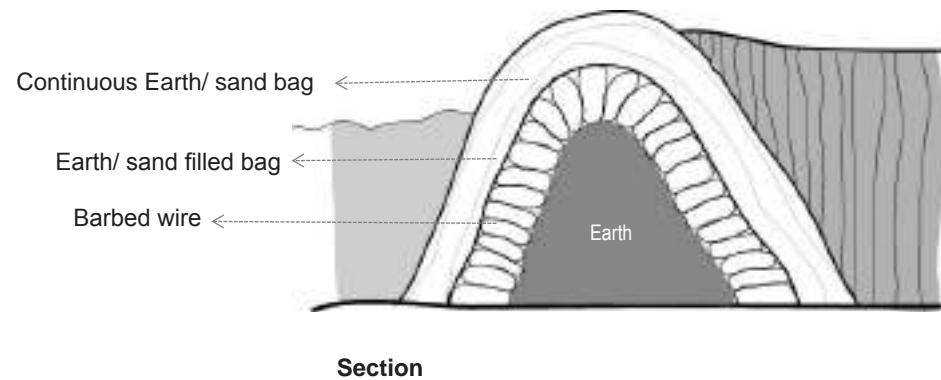
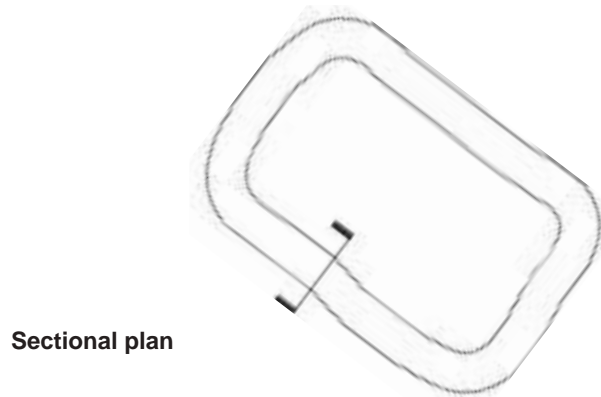



## 4.7 DESIGN RATIONALE

Haor area, unlike coastal zone or flood-influenced regions, shows more permanent form of residency of inhabitants. Cluster or linear form of communal settlement pattern can be seen at villages. Besides, demographic profile of families ask for house forms of somewhat longer dimensions. Demand for granary storage facility also requires additional floor area. Therefore, no small house module has been proposed for this region. All the settlements

are suggested to get built on raised mounds. Such mode of construction eventually eliminated need for introducing extra overhead refuge place and associated exit door too.

The dimension of the proposed house model was derived largely in accordance with local unit of measurement (1 haat = 1'-6") apart from providing a compact space for conducting a secured living.

## CHAPTER FIVE

# DESIGN FOR HILLY AREAS



Source: Public Health & Environment Database

### 5.1 GEOGRAPHIC PROFILE

The hilly regions at Chittagong hill tracts, owing to the rugged profile of the landscape presents a tough ground for the local inhabitants. The region borders the hilly North Eastern India and also South East Asian country of Myanmar. Defined by its higher altitudes, the whole tract experiences immense precipitation in forms of monsoon rain and regular cloud drenching. This particular climatic aspect exposes the barren land to the escalated risk of heavy erosions and hence consequential land slide. The same reason of seasonal heavy downpour causes periodical flash flood that often takes its toll in forms of life casualties and property damage. The higher moisture content in atmosphere results in an ambiance of higher relative humidity which can significantly affect the sense of climatic comfort.

### 5.2 CLIMATIC FACTORS FOR DESIGN CONSIDERATIONS

The generic and case specific climatic features of hilly region are:

- ▶ Land Slide
- ▶ Humidity
- ▶ Driving Rain
- ▶ Higher Rainfall
- ▶ Storms
- ▶ Earthquake

### 5.3 HAZARD PROFILE

The hilly region located in the South-Eastern part of Bangladesh faces different kinds of natural hazards like Flash Flood, Fire, Land slides; bamboo flowering and earthquake. There are pre-signals of other disasters for people to take action but the earthquake possesses the enormous threat, which may occur anytime without any signal. It is mainly because of the location of tectonic plates under the ground. The Eurasia-India plate boundary passes across beside CHT extending north to south. According to experts, existence of vast seismic gap (time difference between earthquakes) laid high possibility of major earthquake shaking. In the history of last 10 years in CHT there were 05 earthquakes took place which are more local in nature and occurred mainly due to inter plate movements.





## 5.4 PREVAILING PRACTICES

### Local Practices

- ▶ Primarily crafted of natural plant materials.
- ▶ New interventions like introduction of CGI sheet and metal strap Joineries could be observed
- ▶ Houses get decayed by various environmental forces like rain, heat, dew etc.
- ▶ Good performance in terms of cross ventilation.
- ▶ Highly skilled craftsmanship.

### Introduced Housing by Different GOs and NGOs

- ▶ CGI sheet as roofing material is dominant in structure.
- ▶ Stilt houses are provided mostly.
- ▶ In certain houses, galvanized, colored CGI sheets are used as roofing and wall material.

### Community Feedback

- ▶ Houses with flimsy joineries easily susceptible towards various natural forces.
- ▶ Requirement of separate service units(cooking, toilet etc.).
- ▶ Prevailing scarcity and high price of tree logs as structural component.

### Issues Identified

- ▶ Depletion of natural matured vegetation.
- ▶ Skilled craftsmanship over renewable plant material like bamboo and thatch.
- ▶ Natural building material decayed by various environmental forces.

- ▶ Stilt housing.
- ▶ Consideration of habitat accommodation in steep slopes.
- ▶ Stable structural system and material durability appears to be the only scope of intervention



Existing Local Practices in Hilly Regions



Introduced Housing by Different NGOs

## 5.5 TYPICAL HOUSE PLAN OF DIFFERENT INDIGENOUS COMMUNITY

Typical House Plan of Bawm Community

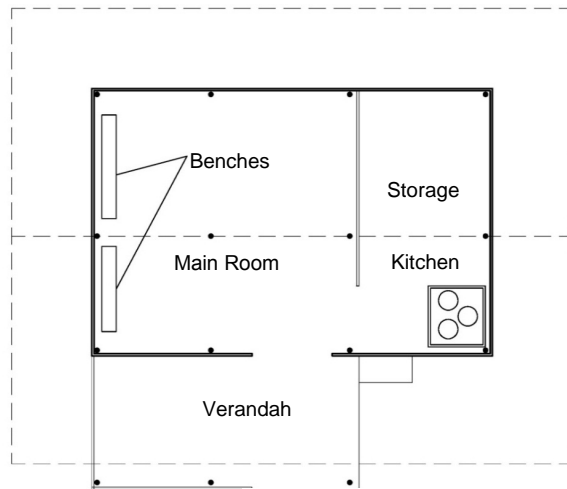

Typical House Plan of Marma Community

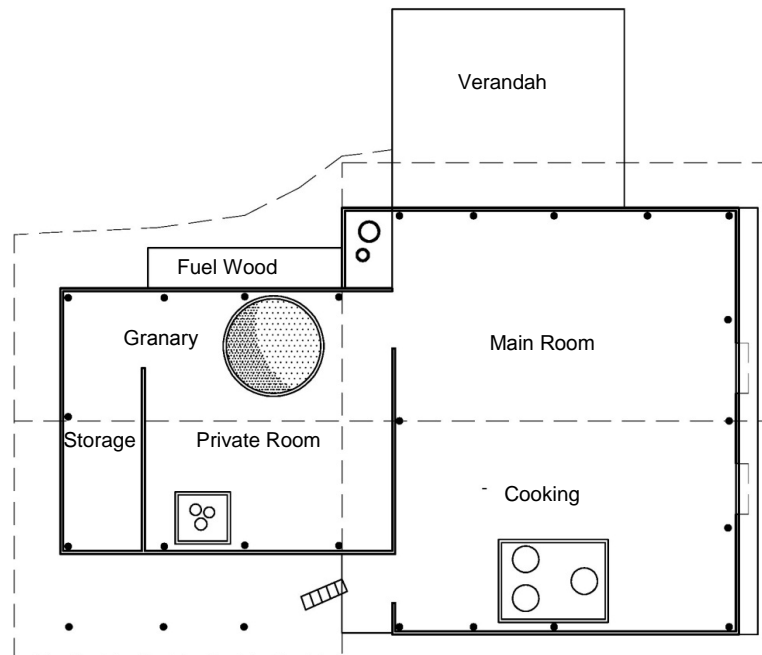
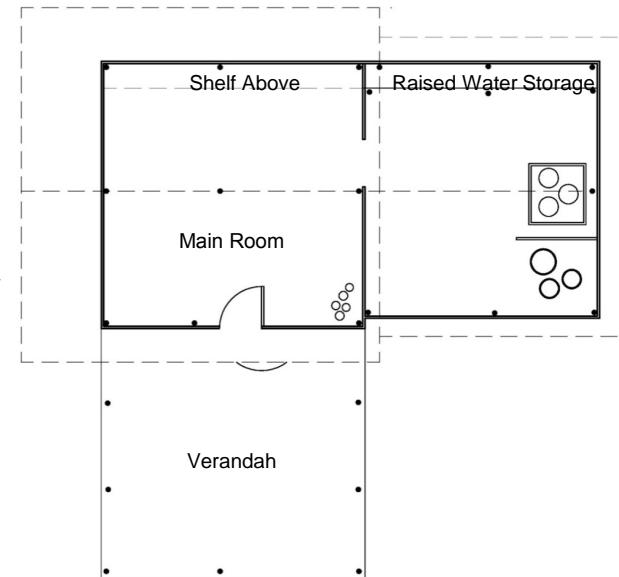

Typical House Plan of Mru Community



## 5.6 PLAN

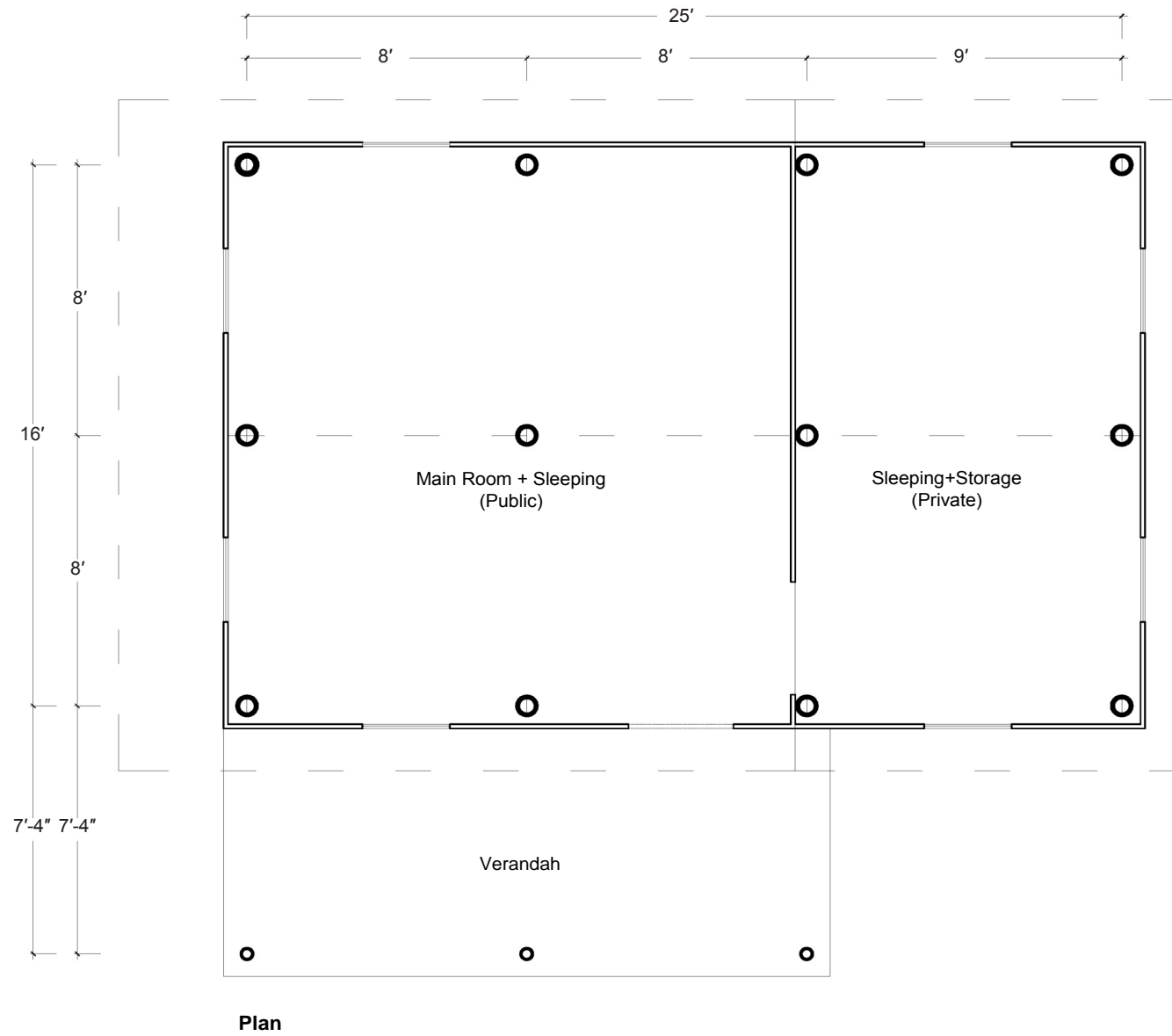

## FORMATION OF HOUSE MODULE

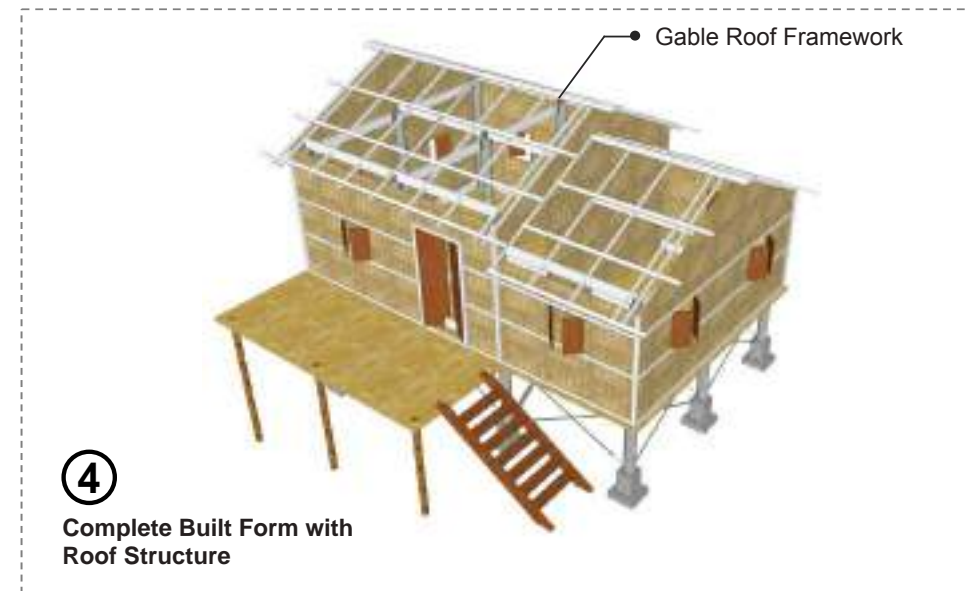
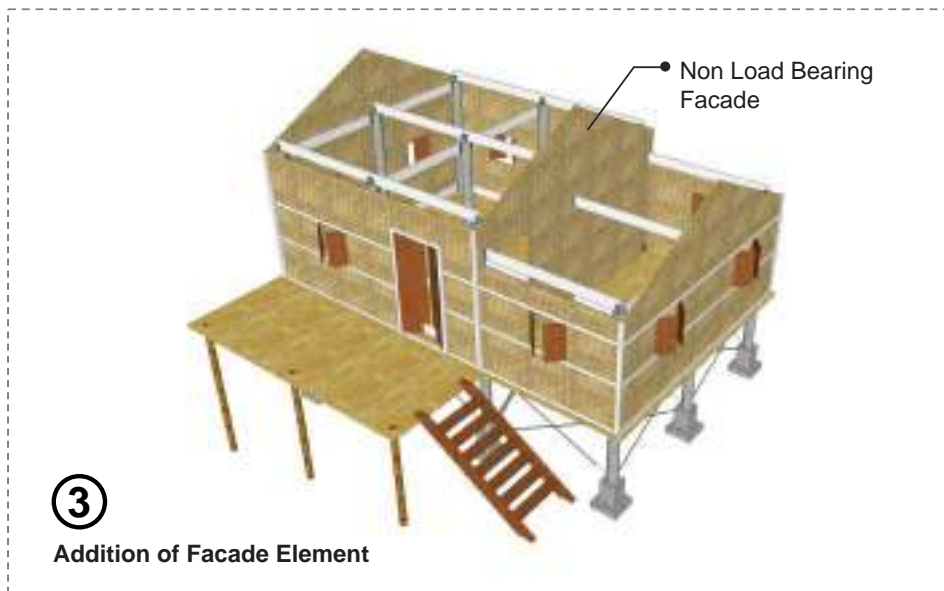
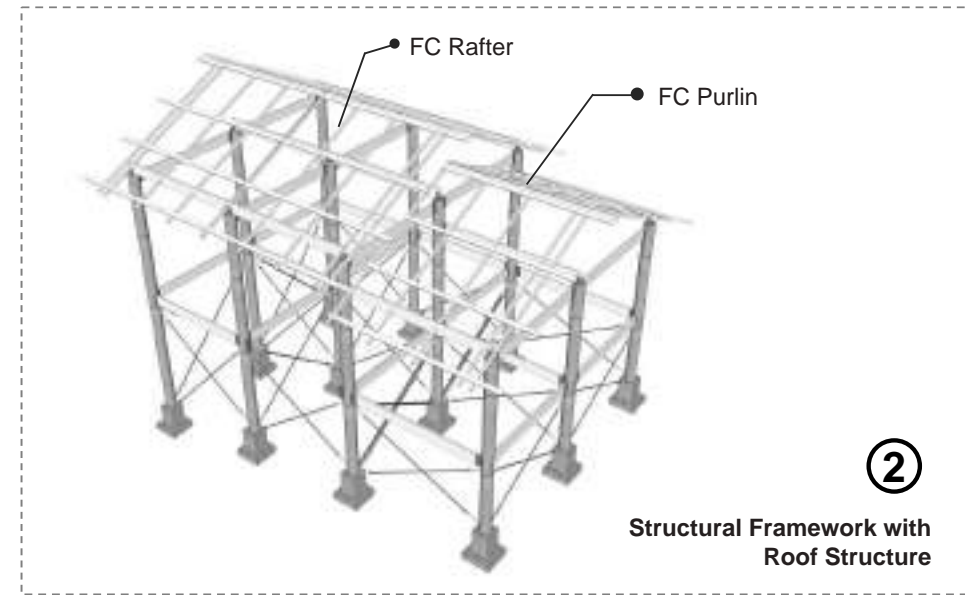
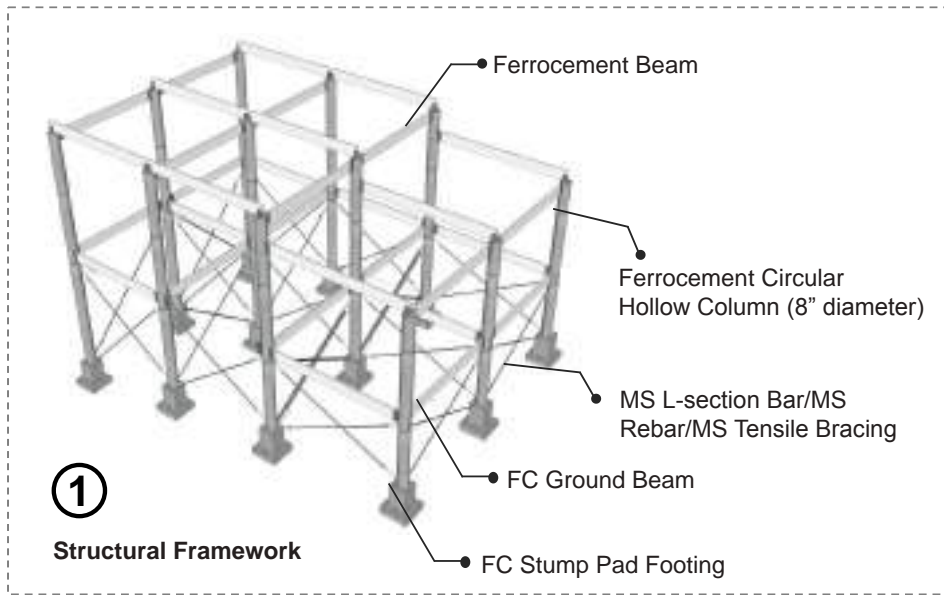

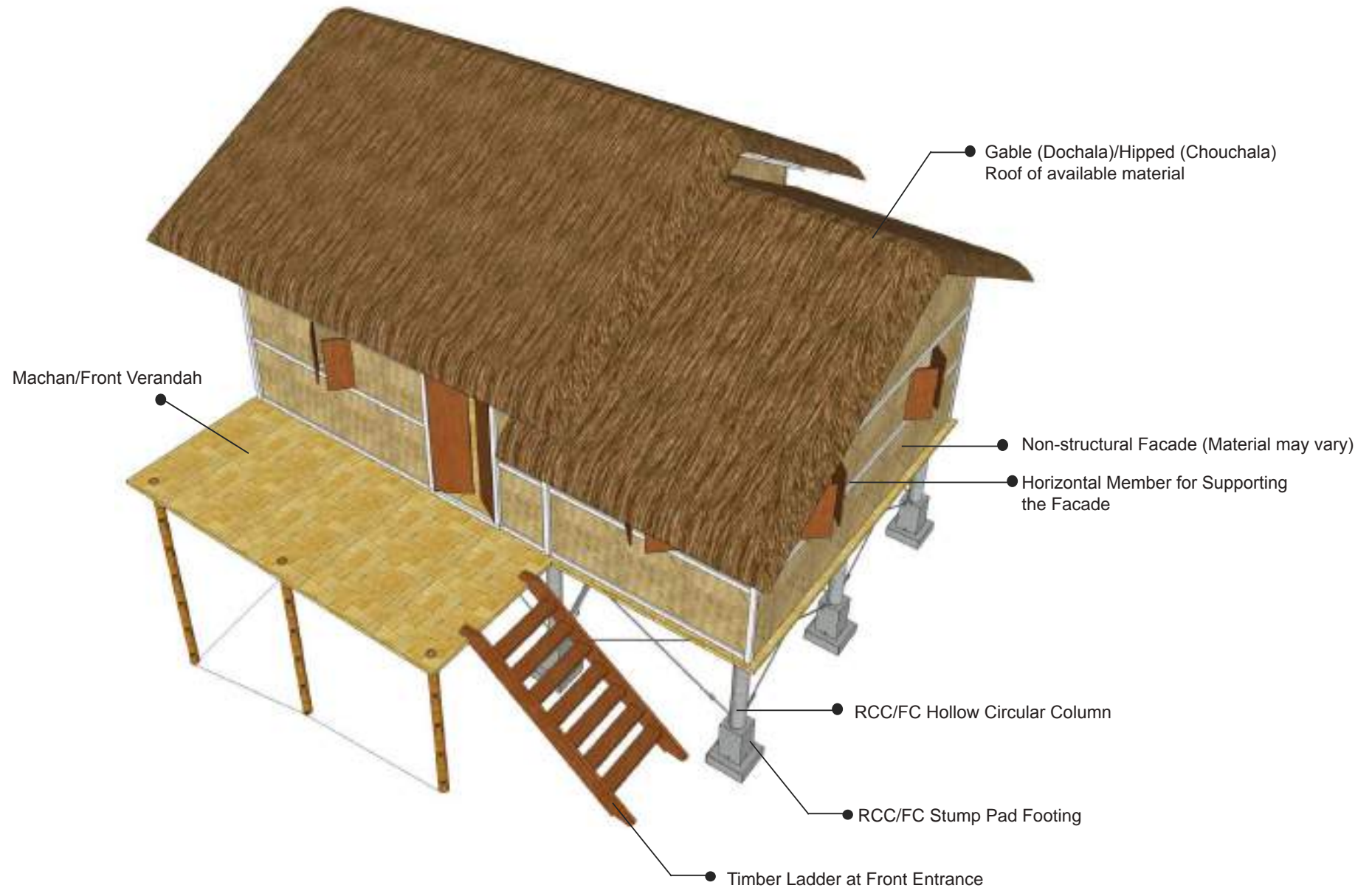
**COMPLETE BUILT FORM**

## 5.7 JOINERY DETAIL

- ① Structural Framework
- ② Exploded View of Ground Beam and Screw Joineries with Metal Bracket
- ③ Secured Assemblage of Ground Beam with Metal Bracket

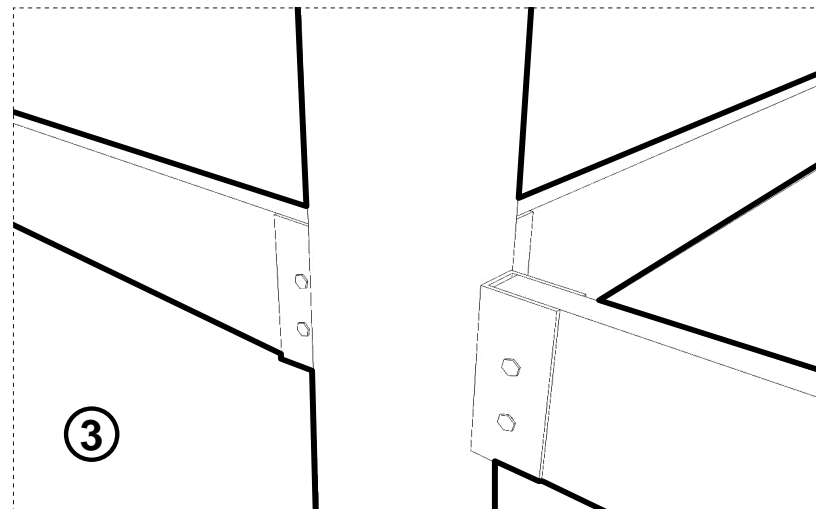
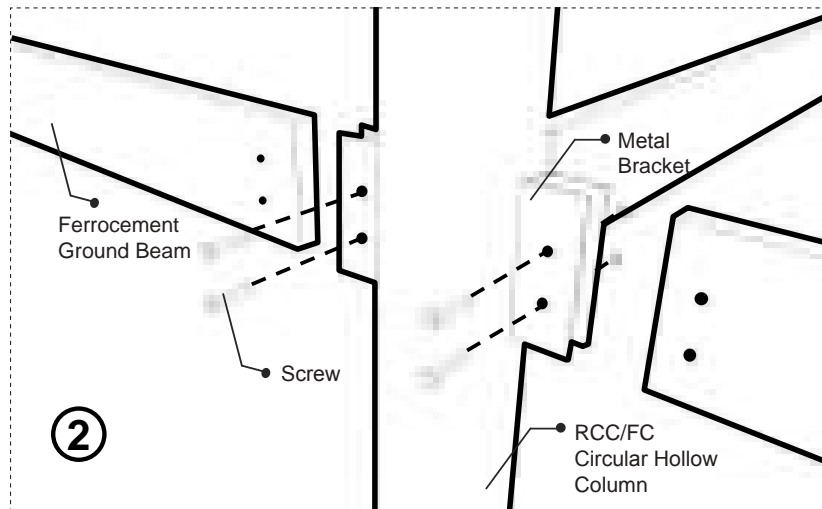
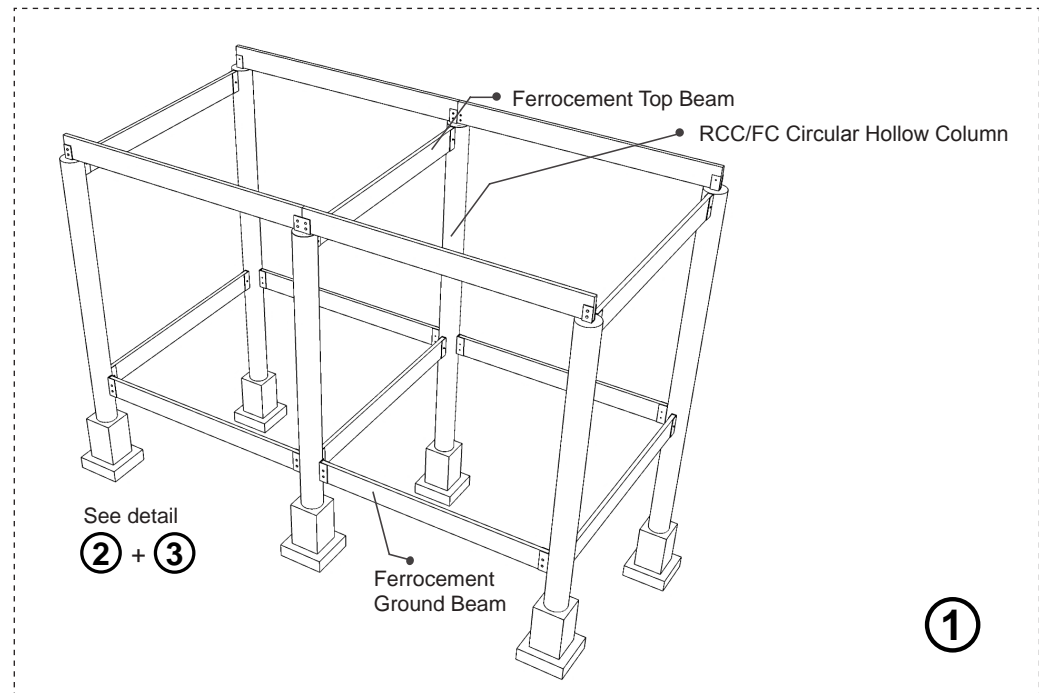

- ④ Structural Framework
- ⑤ Exploded View of Column, Top Beam and Screw Joineries
- ⑥ Secured Assemblage of Column and Top Beam

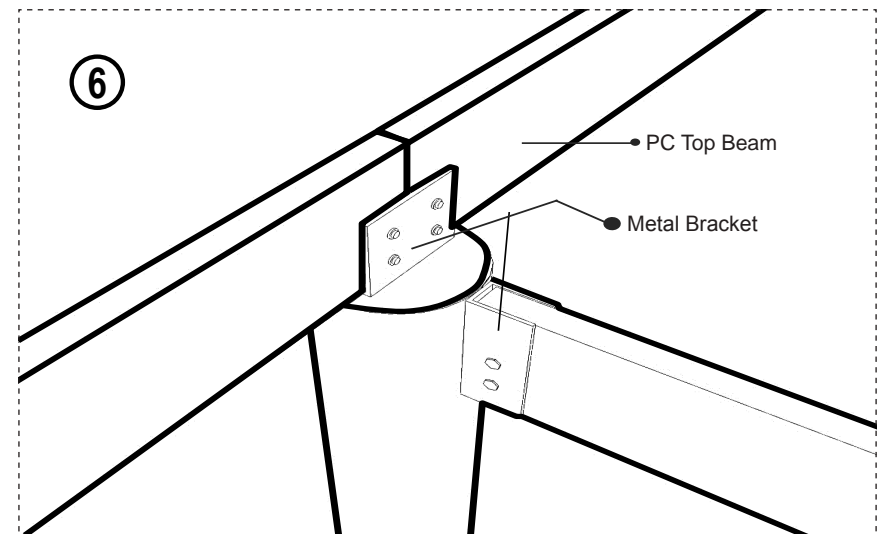
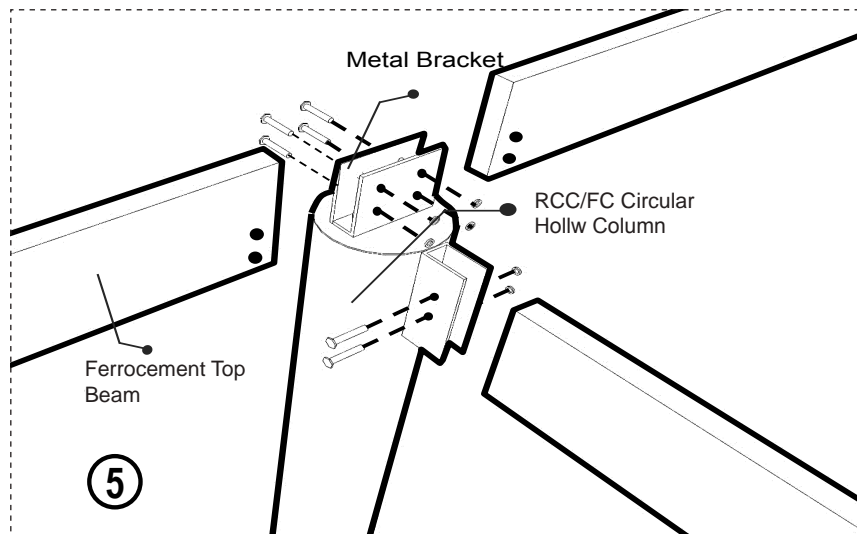
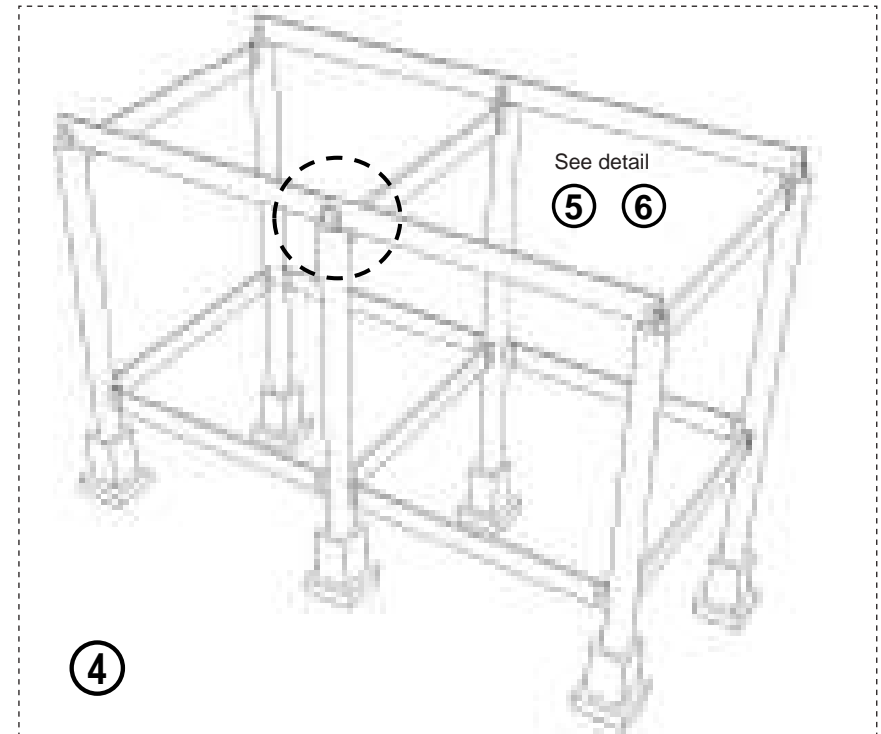





## 5.8 DESIGN RATIONALE

The house making culture of diverse indigenous communities at hilly region (mostly of southeastern part of the country) demonstrates a critical and thorough understanding of climate issues and available material properties. It's a rich source of centuries old local and collective wisdom and knowledge. The unparalleled skill of crafting in the scale of entire house making poses a unique value upon all this diverse form of vernacular architecture. They are structurally stable, climatically comfortable

and thematically sustainable in nature for most of the given aspects. It's a living culture heritage. The intervention for such a sensitive area of design had to address such issues. Therefore a design scheme has been referred where only the structural forest woods have been replaced with introduced and advanced mode of Ferrocement framework elements such as Hollow circular columns and lightweight rectangular beams along with MS hardware components. The practice of harvesting bamboo as a replenishing

building material has been promoted. However, quick deforestation rate of such a diverse wildlife and biodiversity hotspot region had to be considered and hence comes the structural interventions. The local practices and beliefs regarding spatial planning of all the indigenous community has been respected and addressed duly in cherishing the prevailing ones.



## CHAPTER SIX

# OTHER FORMS OF HOUSE PATTERN

## 6.1 MULTI STOREY STRUCTURE

### 6.1.1 Design Considerations

- ▶ Vertical Circulation
- ▶ Service
- ▶ Semi-public Circulation
- ▶ Public
- ▶ Private
- ▶ Future Extension

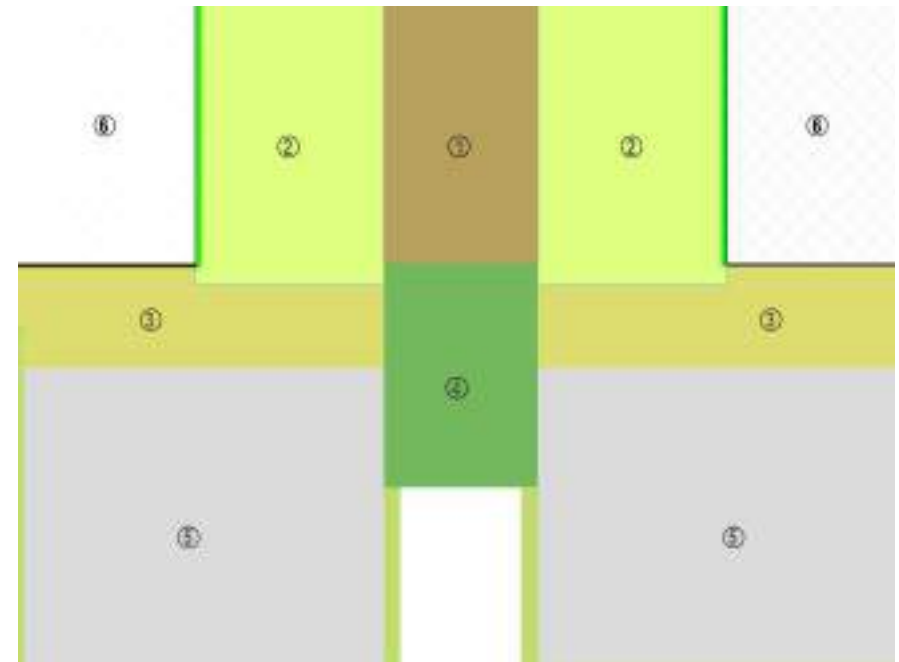

### 6.1.2 Plan

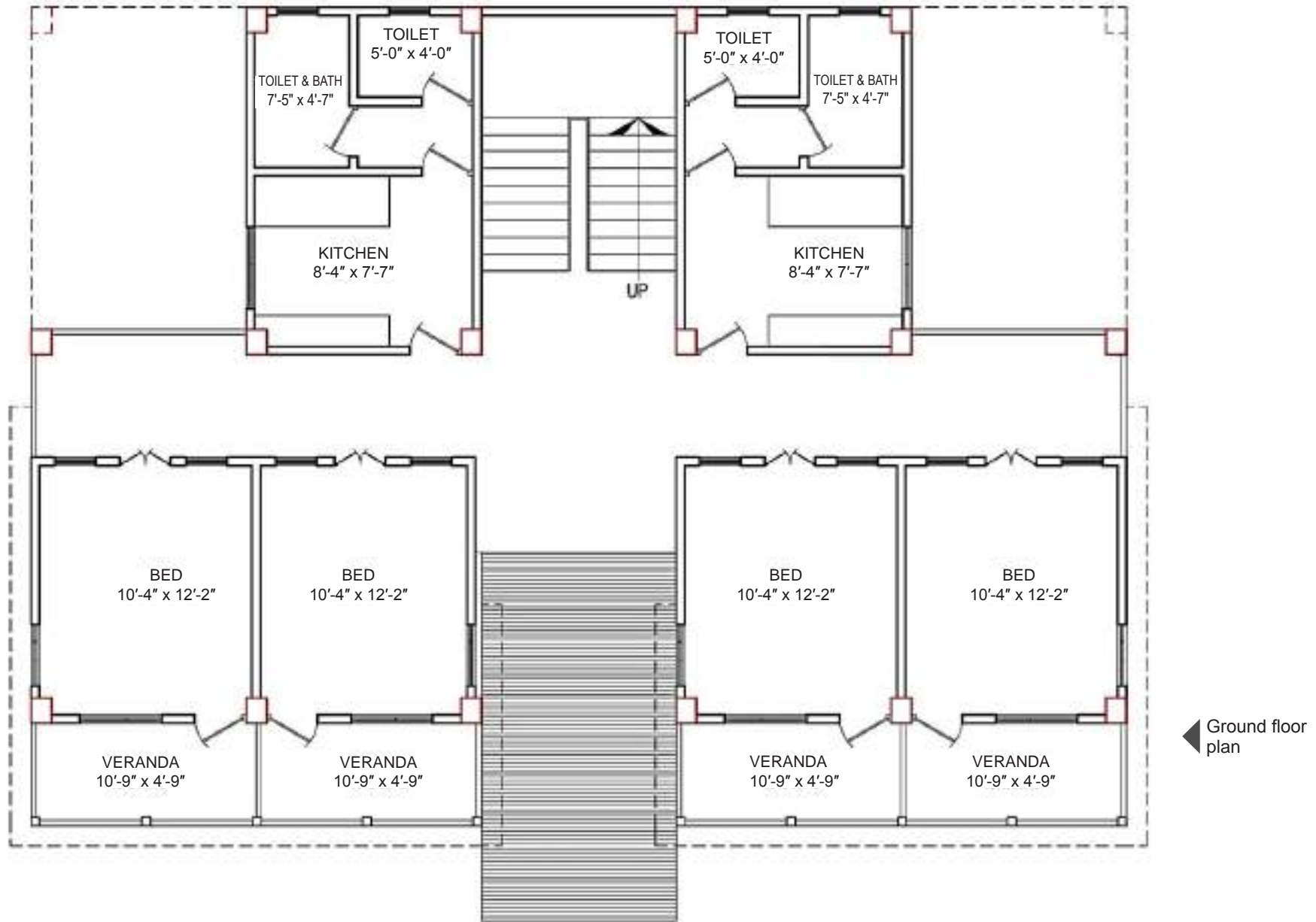

### 6.1.2 Plan (Cont.)

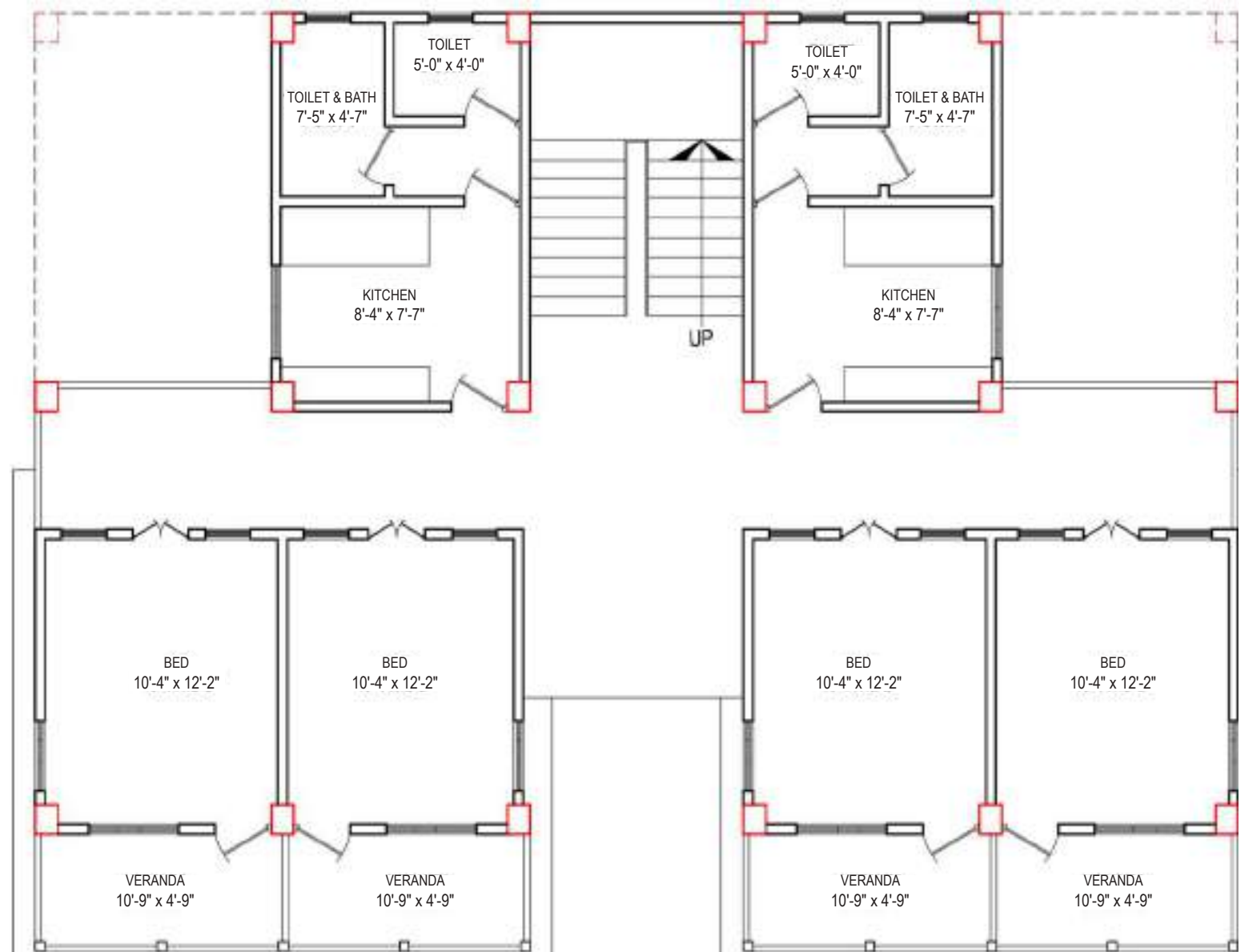

Typical floor plan ►

### 6.1.2 Plan (Cont.)

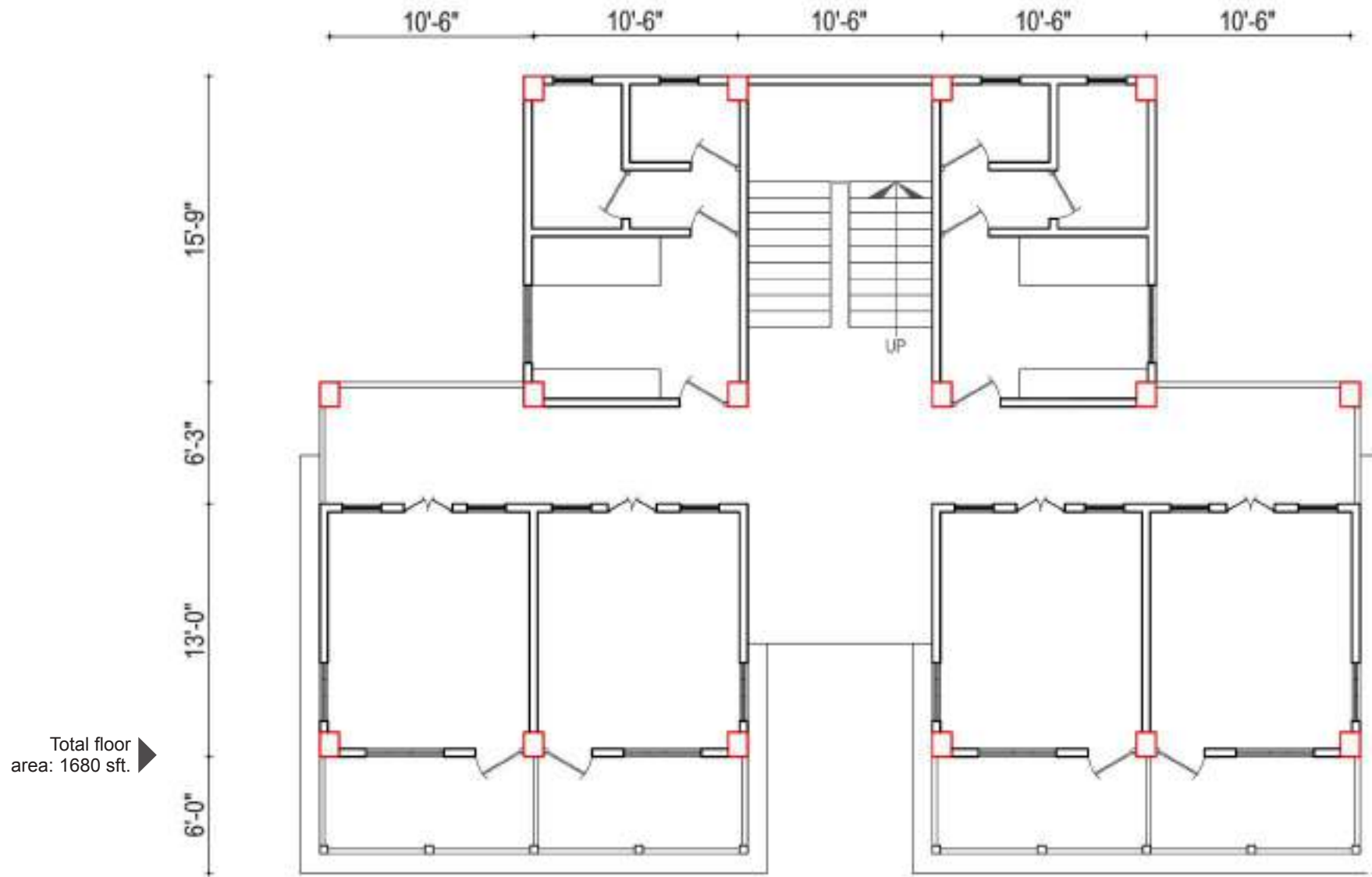



### 6.1.3 Section

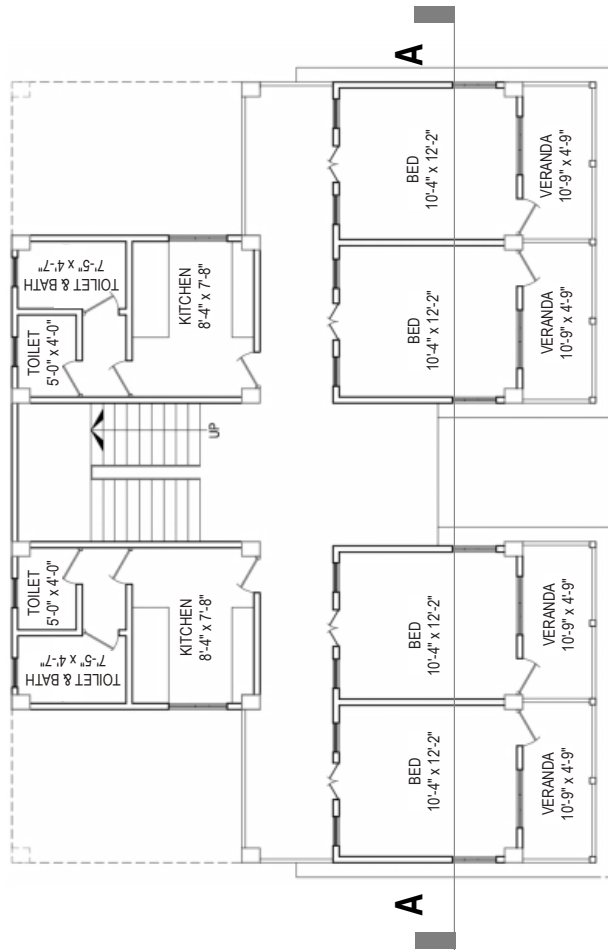

Section AA



### 6.1.3 Section (Cont.)

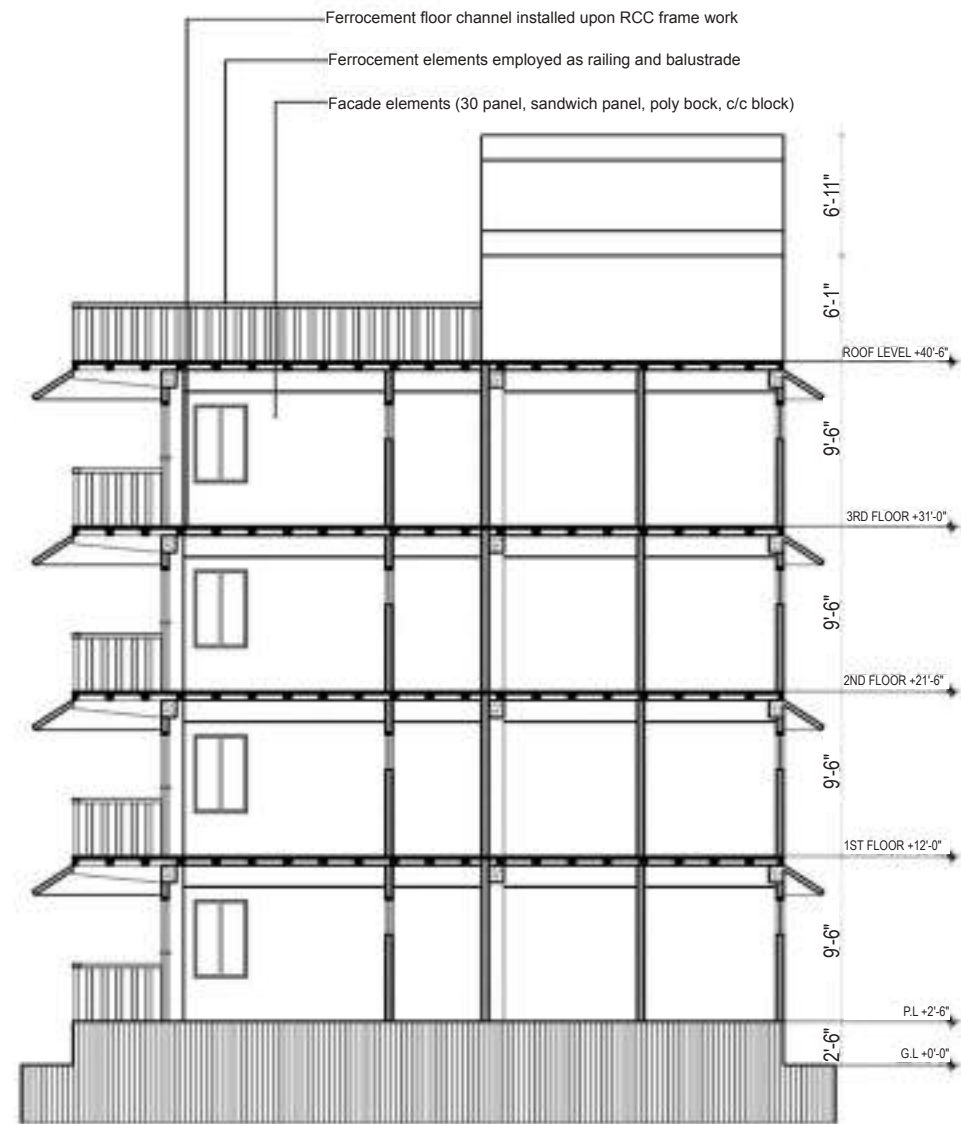
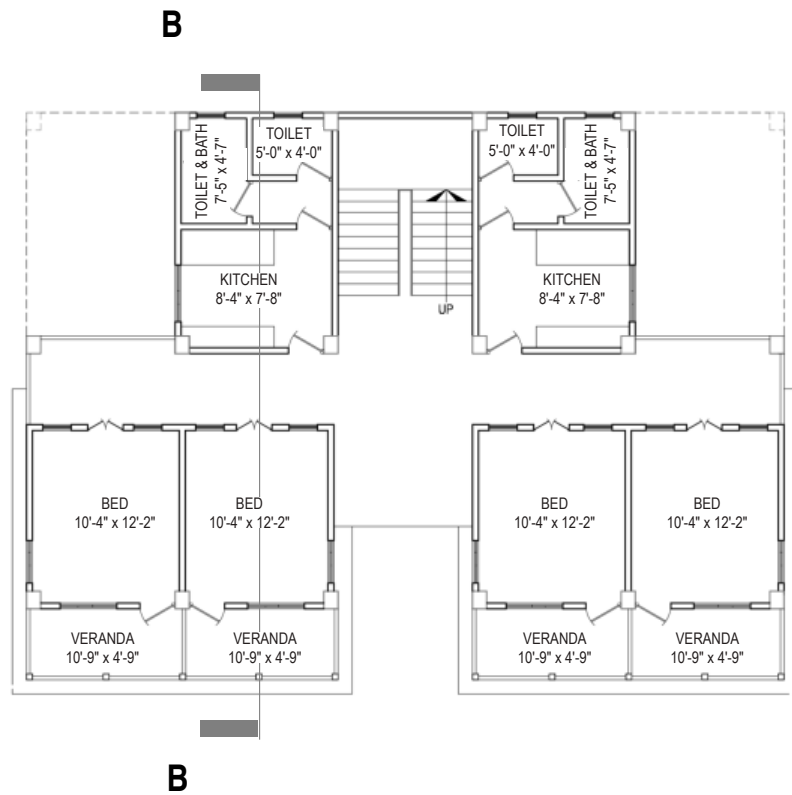

Section BB

## DIFFERENT FORMS OF STOREY FORMATION

Single Storey ▶



Two Storey ▶

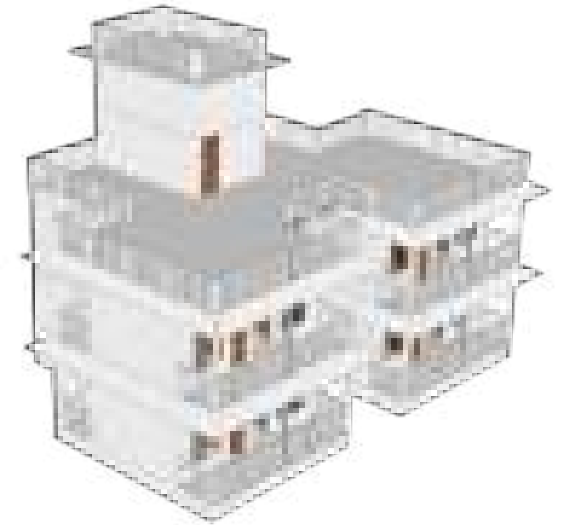

◀ Four Storey



◀ Three Storey



### 6.1.4 Flexibility in terms of Extra Space Usage and Future Expansion

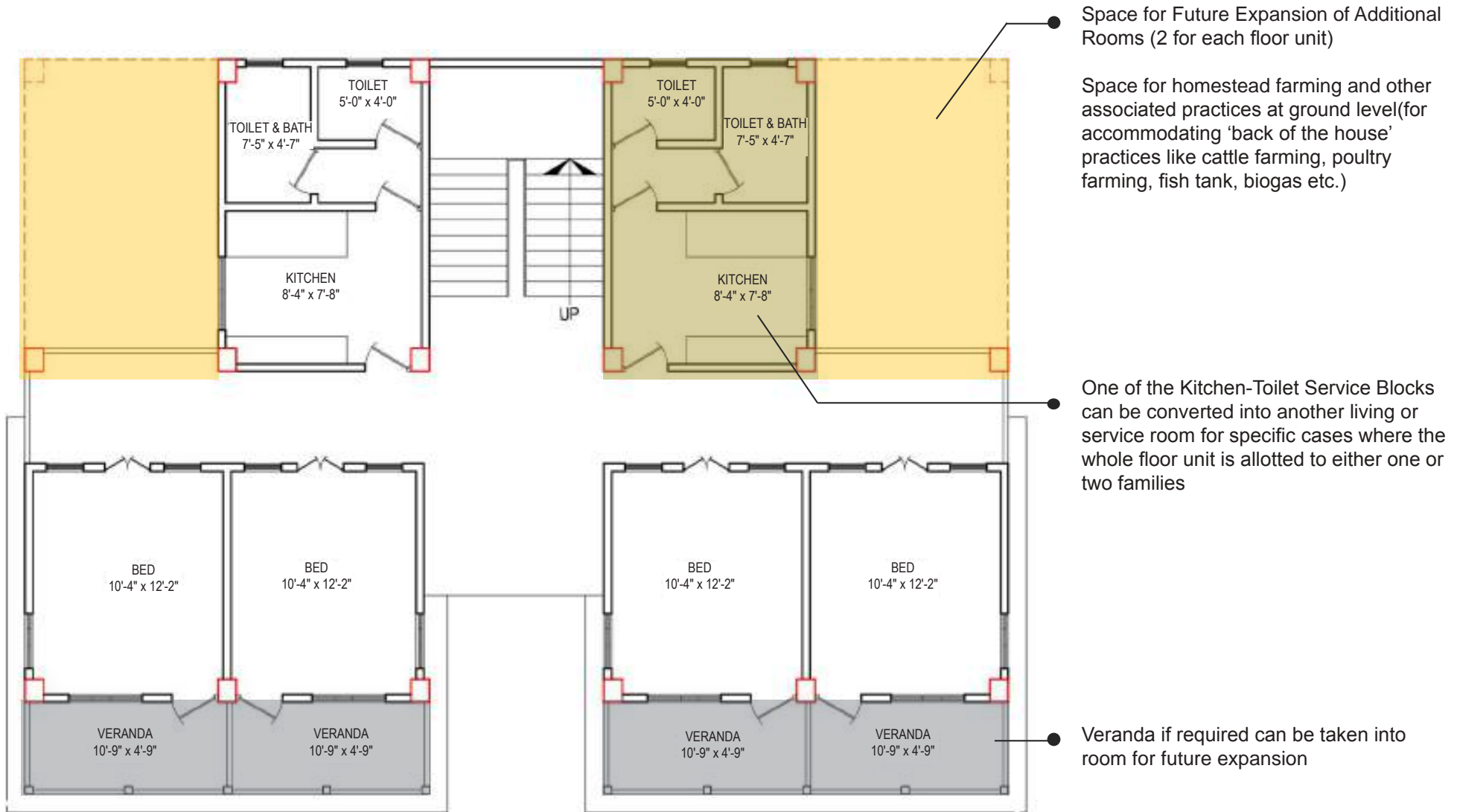

### 6.1.5 Settlement Formation

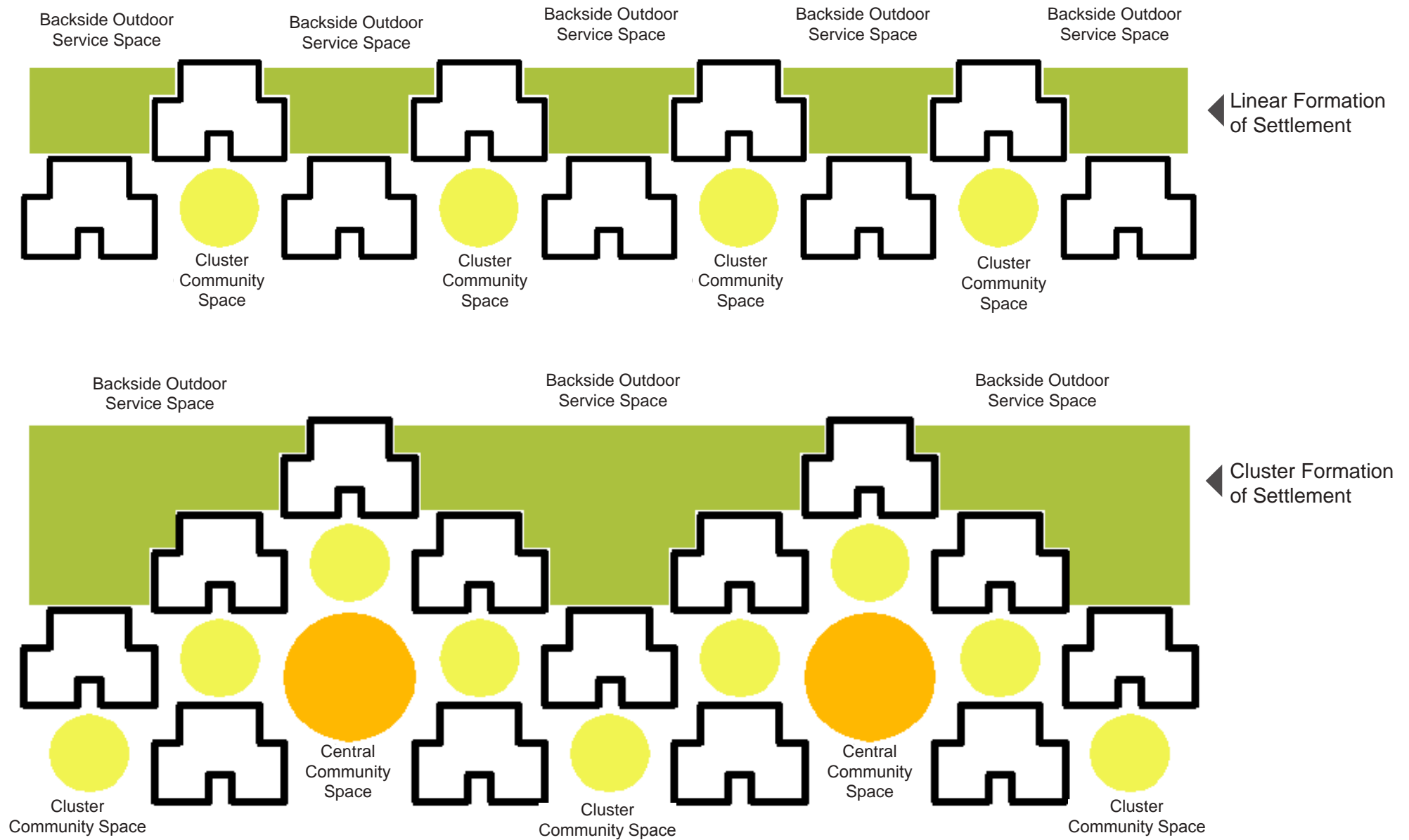



## 6.1.6 Climatic Considerations

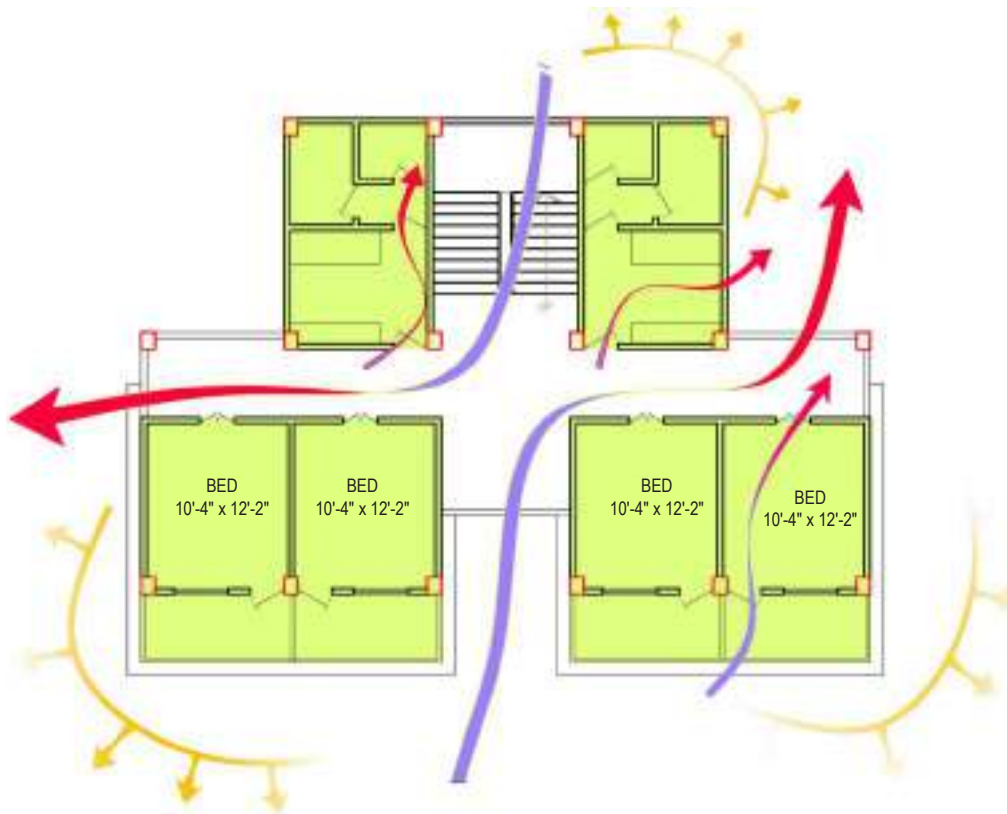

Collection of fragmented forms help in quick cooling off the whole mass via radiated heat dissipation and enhanced mode of cross ventilation

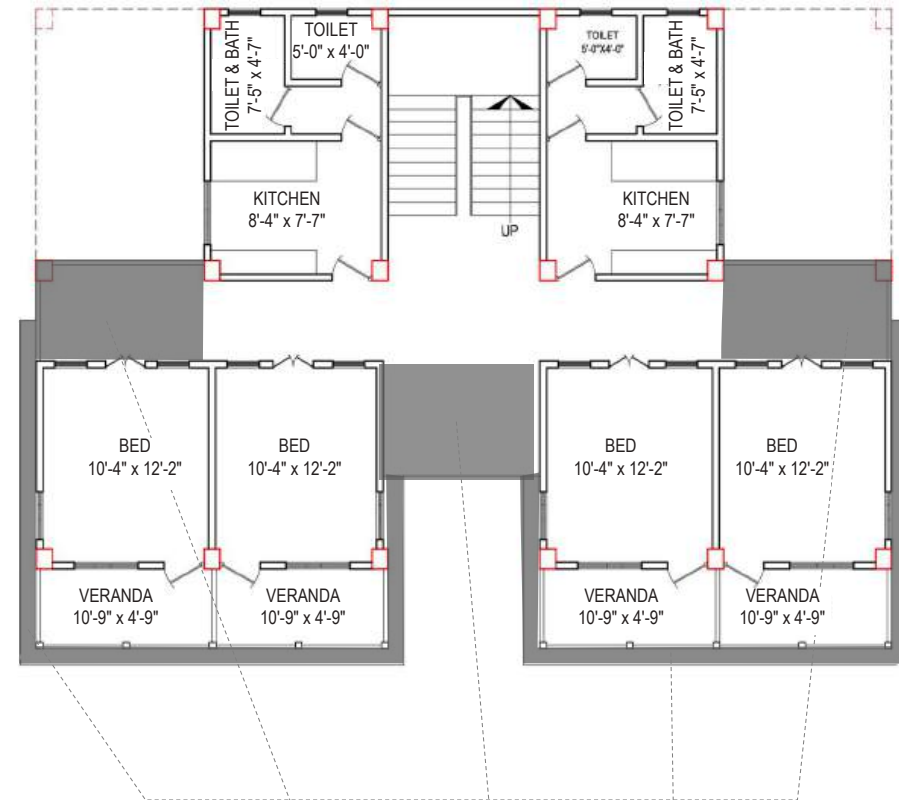

Shading Devices all around the living units in forms of either balcony, eaves or corridor turns the structure into somewhat a heat sink rather being a thermal mass and hence reduce the degree of heating up.

### 6.1.7 Structure & Material

Facade Elements



Roofing and slab Element

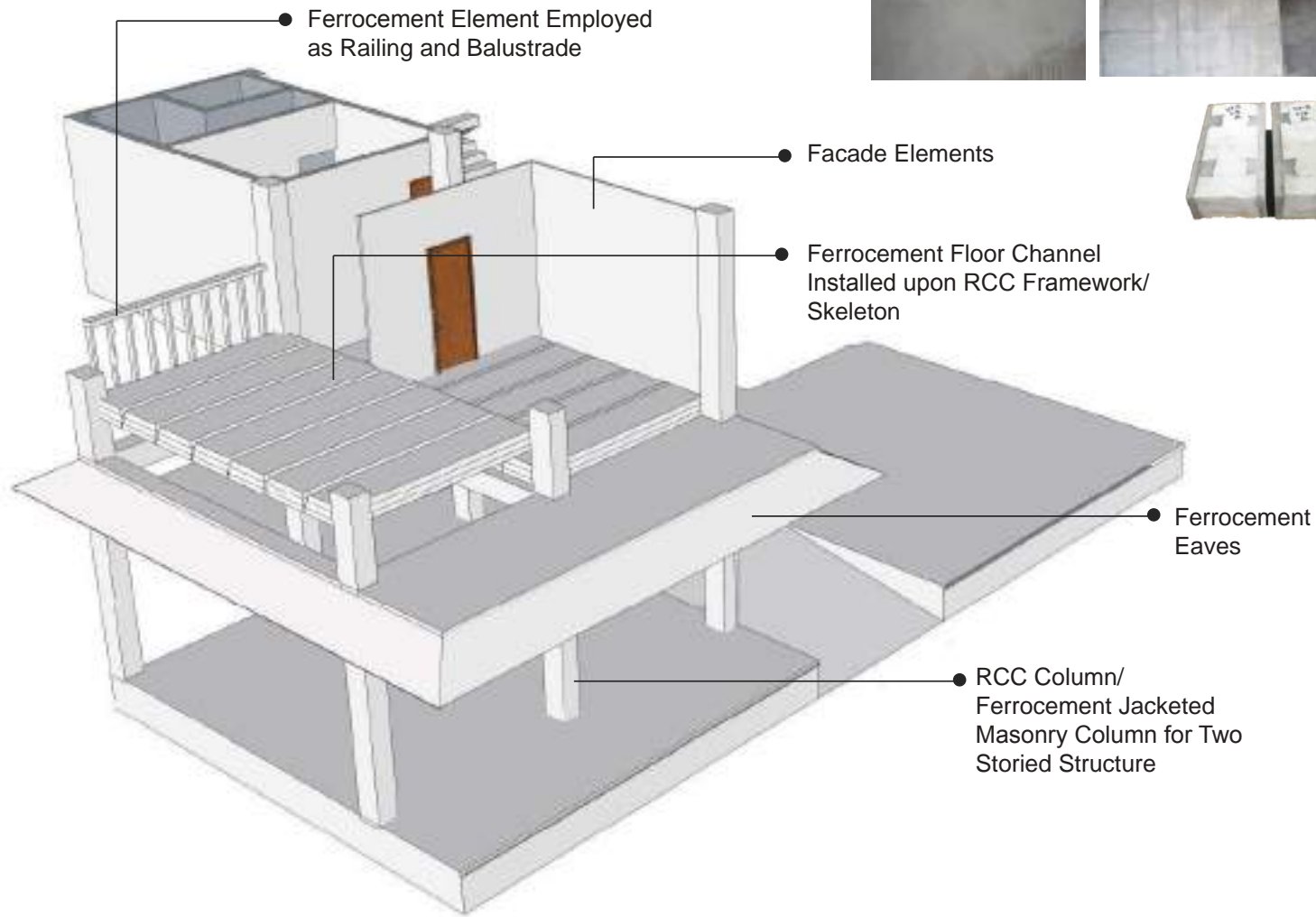

## PERSPECTIVE VIEW



## 6.1.8 Other examples of Multistory Structure

### 6.1.8.1 Five Storey Model House Built in HBRI Premises

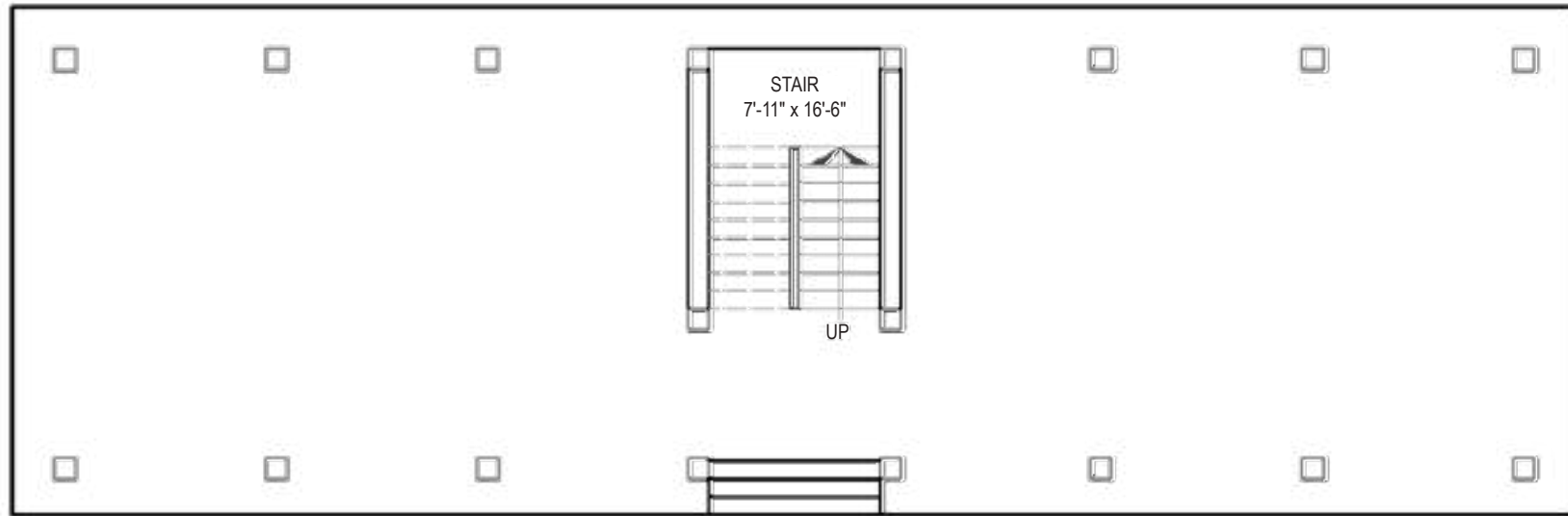

Ground Floor Plan

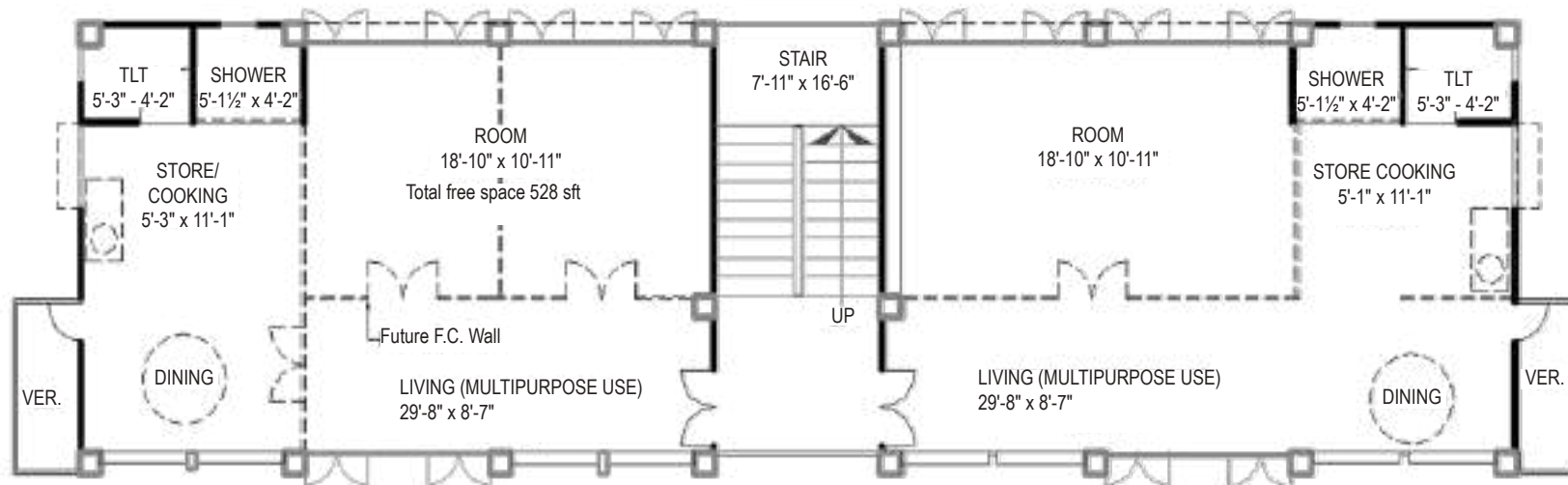

Typical Floor Plan



## ELEVATION









## PERSPECTIVE VIEW



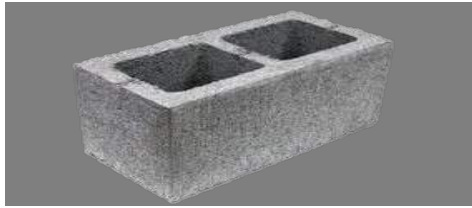

## 6.1.9 Specification for Facade Elements (Multistory)

SL	Material	Description	Specifications	Cost	Image
1.	Ferrocement	<ul style="list-style-type: none"> <li>▶ Ferrocement is ideally suited for thin wall structures as the uniform distribution and dispersion of reinforcement provide better crack resistance, higher tensile strength to-weight ratio, ductility and impact resistance.</li> <li>▶ Ferrocement elements can be divided into two categories based on the construction procedure- Cast-in-situ Pre- Cast</li> </ul>			
	a. Cast-in-situ	<ul style="list-style-type: none"> <li>▶ Cast in situ ferrocement includes the procedure of constructing the element in the particular site.</li> <li>▶ Its difficult to maintain the size, shape and thickness of the element.</li> <li>▶ Labor charge is high.</li> <li>▶ Assembling cost is high in this type of construction.</li> </ul>	<ul style="list-style-type: none"> <li>▶ Cement :Sand=1:2.</li> <li>▶ Sylhet Sand having F.M 2.2- 2.6 is used as fine aggregate.</li> <li>▶ W/C=0.45.</li> <li>▶ Iron wire mesh= 2-layers of 18 BWG or 20 BWG with 1/2" opening.</li> <li>▶ Skeleton rod=8mmφ(both way) @2'c/c</li> </ul>	Cost per unit = 135 Tk/sft	
	b. Pre-cast	<ul style="list-style-type: none"> <li>▶ Ferrocement pre cast element can be constructed at convenient places (e.g. factory, workshops) and transported to the sites .</li> <li>▶ Its easy to move from the place of manufacturing to the construction site.</li> <li>▶ Labor charge is comparatively low.</li> <li>▶ Less efforts are required to maintain the size, shape and thickness of the element.</li> <li>▶ In order to avoid the issues related to salinity in coastal areas pre cast ferrocement elements can be <b>proved to be more preferable.</b></li> </ul>	<ul style="list-style-type: none"> <li>▶ Cement :Sand=1:2</li> <li>▶ Sylhet Sand having F.M 2.2- 2.6 is used as fine aggregate.</li> <li>▶ W/C=0.38-0.45</li> <li>▶ Iron wire mesh= 2-layers of 18 BWG or 20 BWG with 1/2" opening.</li> <li>▶ Skeleton rod=8mmφ(both way) @2'c/c.</li> </ul>	Cost per unit = 120 Tk/sft	
2.	3D Panel	<ul style="list-style-type: none"> <li>▶ 3D panel is a prefabricated panel, which consists of a super-insulated core of rigid expanded polystyrene, sandwiched between two sheets of steel welded wire fabric mesh.</li> <li>▶ 2.5 mm diameter galvanized steel truss wire is pierced through the polystyrene core at offset angles for superior strength and integrity and welded to each of the outer layer sheets of eleven-gauge steel welded wire fabric mesh.</li> </ul>	<ul style="list-style-type: none"> <li>▶ Total thickness of mortar(Cement: Sand=1:3) on interior and exterior faces = 62.5 mm</li> <li>▶ Sylhet Sand having F.M 2.2- 2.6 is used as fine aggregate.</li> <li>▶ W/C= 0.45</li> <li>▶ Diameter of welded wires= 2.5 mmφ</li> <li>▶ Thickness of expanded polystyrene sheet= 37.5 mm</li> <li>▶ Total finishing thickness= 100mm</li> </ul>	Cost per unit =182 Tk/sft	

SL	Material	Description	Specifications	Cost	Image
3.	Sandwich Panel	The sandwich panels are consisted of two thin ferrocement layers, reinforced with one layer of iron wire mesh, with core(middle part)made of Expanded Polystyrene Sheet.	<ul style="list-style-type: none"> <li>▶ Total thickness of the concrete(cement: sand=1:3) on interior and exterior faces = 25 mm</li> <li>▶ Sylhet Sand having F.M 2.2- 2.6 is used as fine aggregate.</li> <li>▶ W/C= 0.45</li> <li>▶ Iron wire mesh= 18 BWG with ½ " opening.</li> <li>▶ Thickness of expanded polystyrene sheet (density-15kg/m3)= 56.25 mm</li> <li>▶ Total finishing thickness= 87.5mm</li> </ul>	Cost per unit = 135 Tk/sft	
4.	Thermal Block	<ul style="list-style-type: none"> <li>▶ Thermal block is the composition of Expanded Polystyrene Sheet and Mortar(Cement and Sand).</li> <li>▶ Commonly used as facade material.</li> <li>▶ Improves the thermal property of indoor environment. Can be used in frame structures.</li> <li>▶ Lightweight though reduces overall mass of the structure.</li> </ul>	<ul style="list-style-type: none"> <li>▶ Cement:Sand= 1:4</li> <li>▶ Sylhet Sand having F.M 2.2- 2.6 is used as fine aggregate.</li> <li>▶ Size: 9.5" ×4.5" ×2.75"</li> <li>▶ Compressive strength: approximately 750 psi.</li> </ul>	Cost per unit =135 Tk/sft	
5.	CLC Block	<ul style="list-style-type: none"> <li>▶ Cellular Light Weight Concrete (CLC) is a version of light weight concrete that is produced like normal concrete under ambient conditions.</li> <li>▶ It is 50% Lighter than normal brick</li> </ul>	Size: 20" ×8" ×4"	Cost per unit = 5,768.82 TK/cum	
6.	Sand Cement Hollow Block	<ul style="list-style-type: none"> <li>▶ These blocks are produced by combining sand and cement .Low Maintenance, Color and brilliance of masonry withstands outdoor elements.</li> <li>▶ Strength can be specified as per the requirement.</li> <li>▶ Reduce in total cost of project by being less in dead load of walls.</li> </ul>	<ul style="list-style-type: none"> <li>▶ Size: 9.5" ×4.5" ×8"</li> <li>▶ Sylhet Sand having F.M 2.2- 2.6 is used as fine aggregate.</li> </ul>	Cost per unit = 60 Tk/sft	

### 6.1.10 Roofing Elements

SL	Material	Description	Specifications	Cost	Image
1.	Ferrocement Folded Plate	Folded plates with a trapezoidal cross-section either in the form of a 'hat' or in the form of a trough section give rigidity, ensure safety while handling to a large depth, and an inclined web with a large tension flange to accommodate reinforcements, lending for suitably pre casting / prefabricating.	Size: Flange width=5" Thickness=3/4" Maximum Depth=6" Length= Usually 10'6"(Can be changed as per requirement)	Cost per unit = 175.00 Tk/sft	
5.	Ferrocement Precast Channel	<ul style="list-style-type: none"> <li>▶ A pre cast ferrocement channel roofing element is a trough-shaped element flange, which is made of ferrocement and ribs are of reinforced concrete.</li> <li>▶ The design principle is the same as that of the precast RC channel element.</li> </ul>	Size: Width= 2ft(including rib portions), Length=Usually 12'6"(Can be changed as per requirement ) Thickness: Flange thickness=3/4" Rib Thickness=2"	Cost per unit = 254.00 Tk/sft	



## 6.2 STILT HOUSE

### 6.2.1 Plan

#### STILT HOUSE

The whole house is constituted of prefabricated building kit elements (mostly Ferrocement components) for the ease of construction within the shortest possible time mostly in the long term water inundated geographic areas and also in the regions that face brunt of flash floods. The standardized prefabricated

component based building system also addresses issues like quality construction, ease of portability, relocation and reusability of every building component, future expansion etc. The open ground floor plan provides the options for multipurpose usages like livestock farming, granary storage, etc. This form of structure can also be employed in Cyclone affected regions for tidal surge resilience with due concern

for the impact intensity of the area. However to avoid the false sense of security of the inhabitants the area to be chosen should not experience tidal surge level more than 7' high.

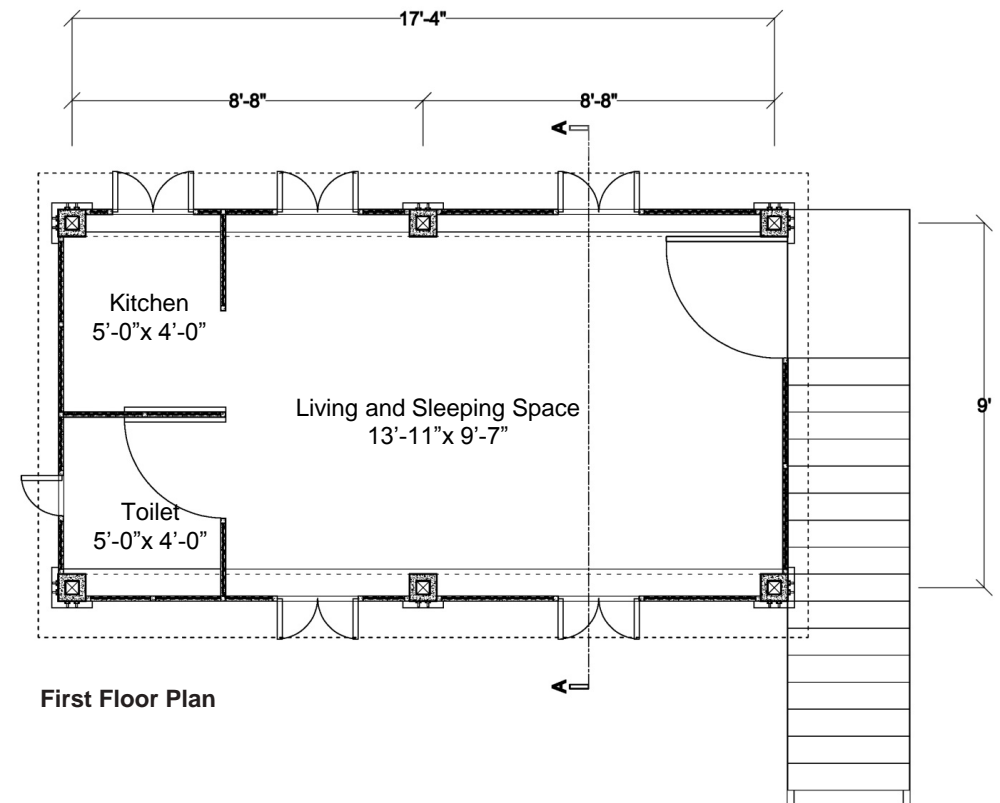
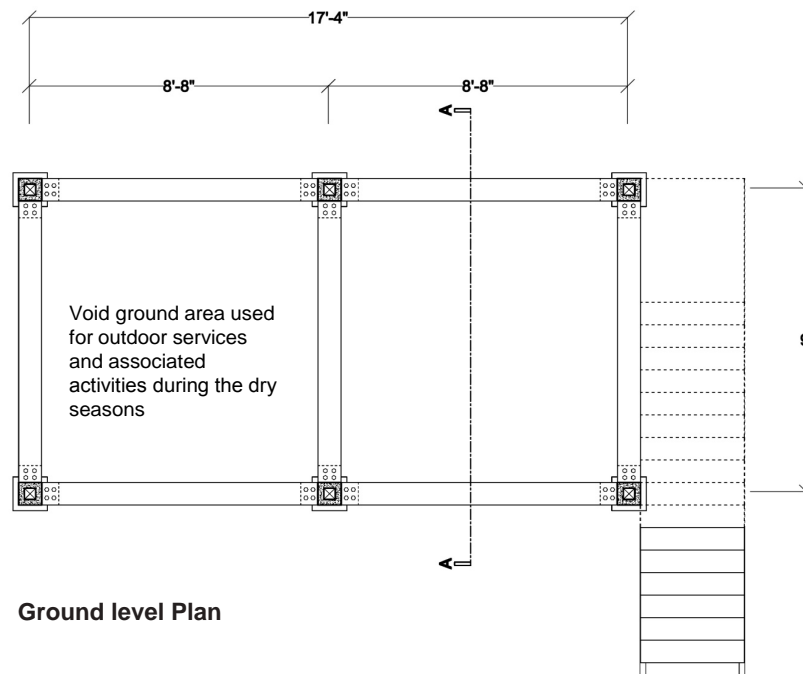



## 6.2.2 Elevation

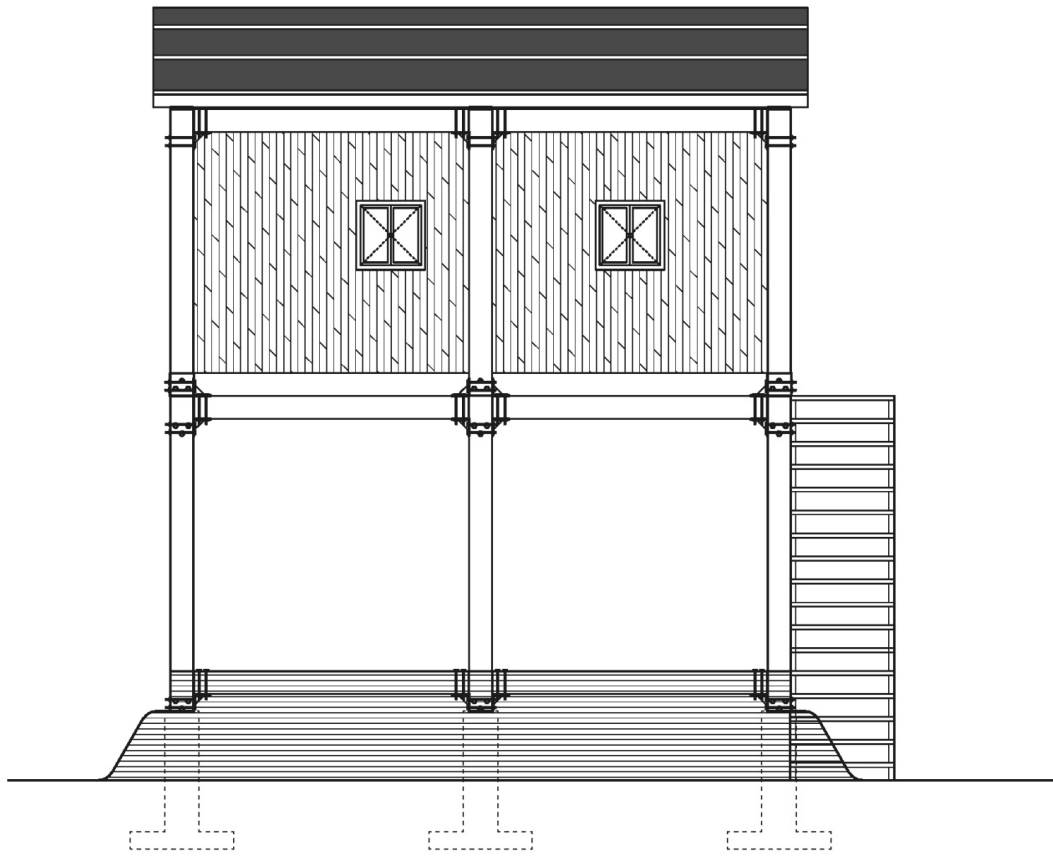

Front Elevation

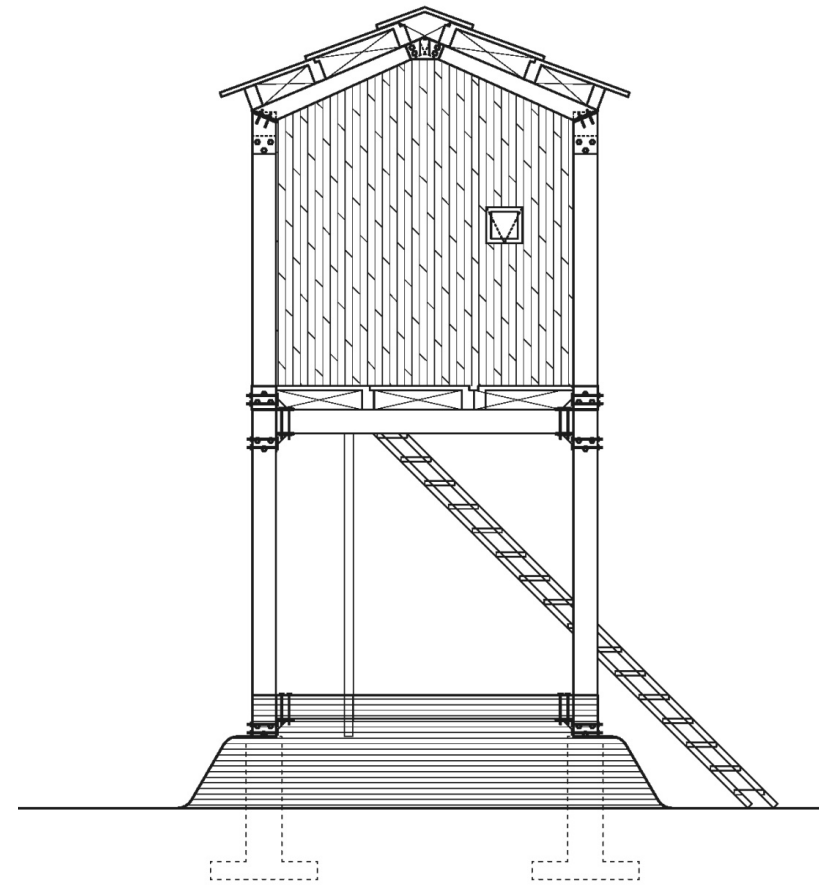

Side Elevation

### 6.2.3 Section

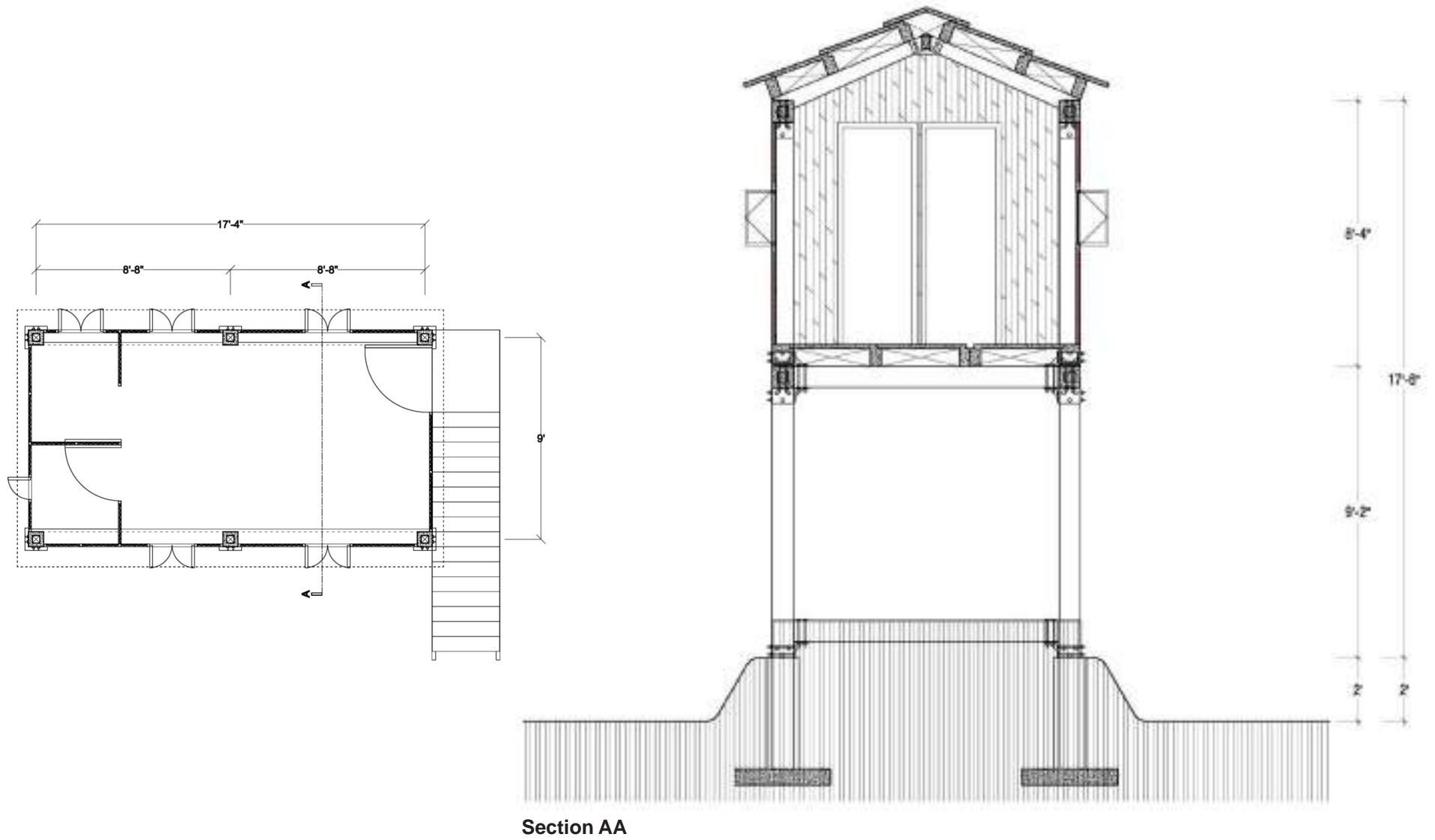

## 6.2.4 Future Expansion



### Single House Unit with Grounded Footings

An improvised form of stump pad footing is employed to form the foundation for the overall assemblage of this stilt house unit.

### Single House Unit with Possible Future Expansion

Considering the Inhabitant's requirement the house module can be multiplied around the given position of the staircase and formed into a cluster of multiple units.



### Single House Unit

The Single House unit comprises of a stair made of metal frame and Ferrocement trades that, if necessary can be shifted in accordance with the future expansion of the households. This flexible staircase, in its fixed position, can also indicate the directions for the future cluster formation.



## EXPLODED AXONOMETRIC VIEW OF THE SINGLE UNIT STILT HOUSE

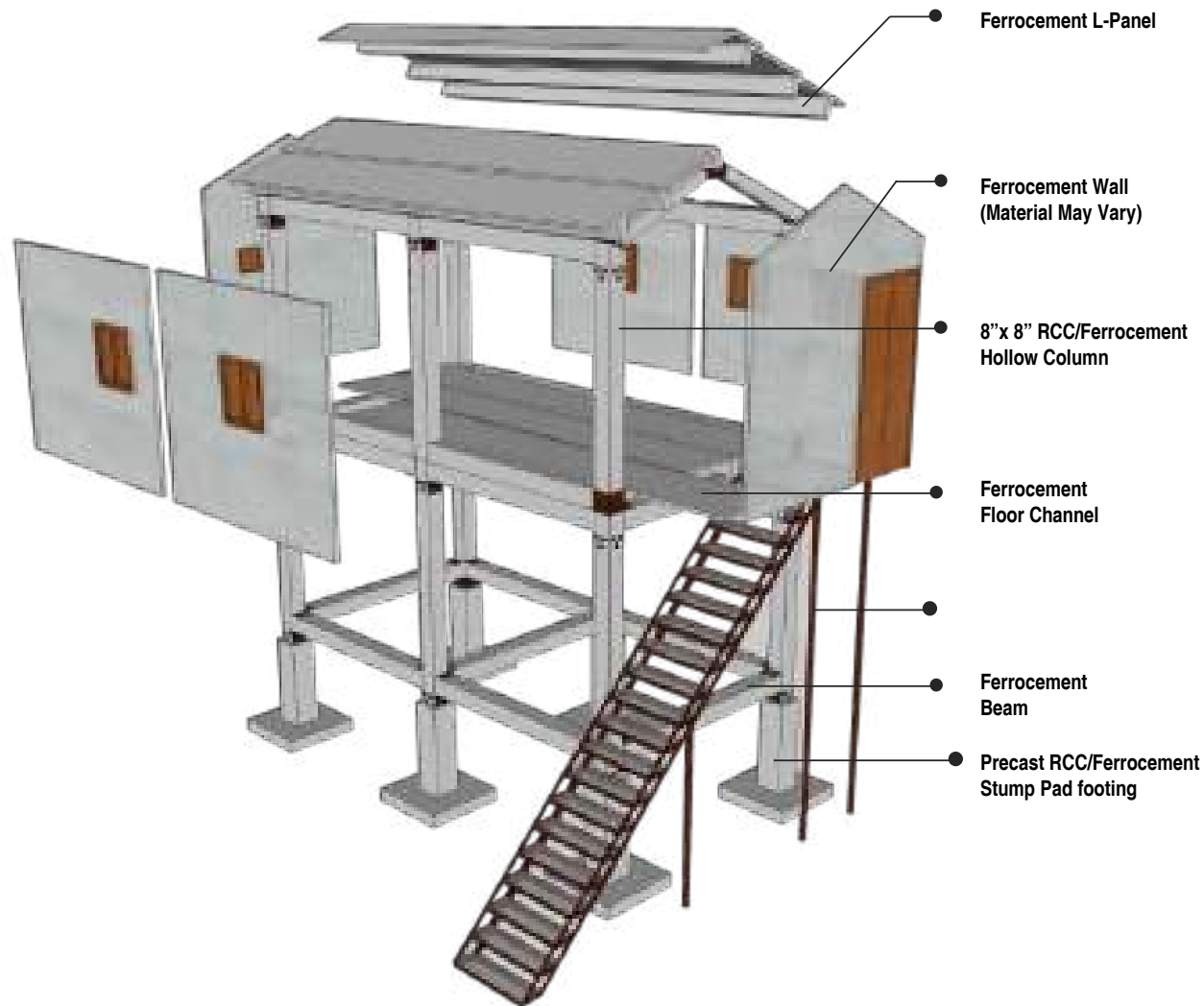

### Roofing Elements



### Facade Elements



Bamboo Matt



Bamboo Matt (Plastered)



Ferrocement (Cast-in-situ)



3D Panel



Sandwich Panel



CSEB



Thermal Block



Aerated Concrete Block



Poly block with EPS Bubble

### Slab Elements



Ferrocement Channel



Ferrocement L-Panel

### Footing Column & Beam Elements



## 6.2.5 Joinery Details

### Exploded View of Bolted Metal Haunch Joineries between Column and Beam Components

This blow up detail shows how the upper level prefabricated stilt house components are fixed to the ground level components.

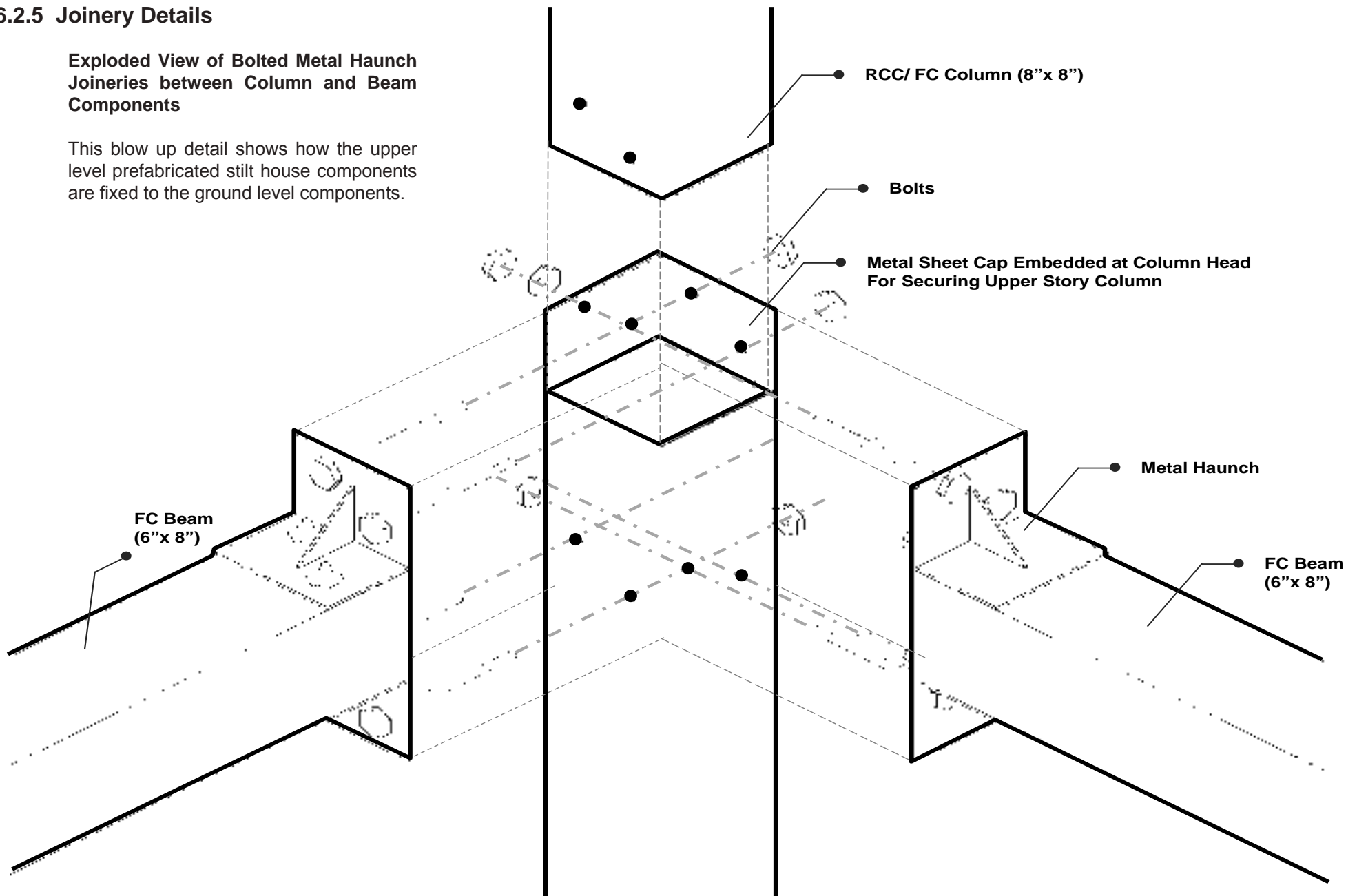



## 6.2.5 Joinery Details (Cont.)

Exploded View of Bolted Metal Haunch Joineries between Column and Beam Components

### Secured Assemblage of Column and Beam Elements with Bolted Metal Haunch Joineries

The figure shows the finished joint between upper level column and ground level beam-column components.

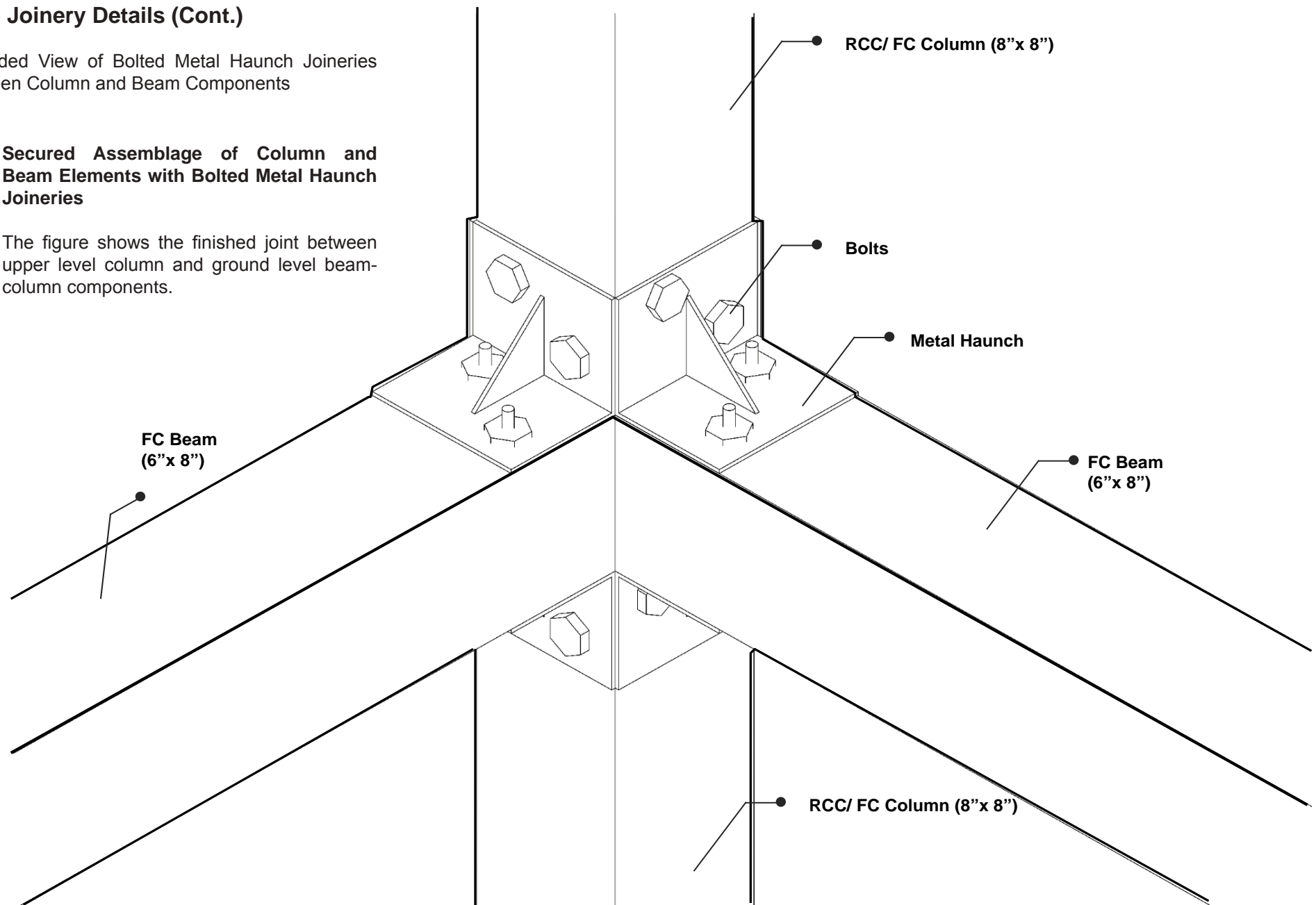

### 6.2.5.1 Structural

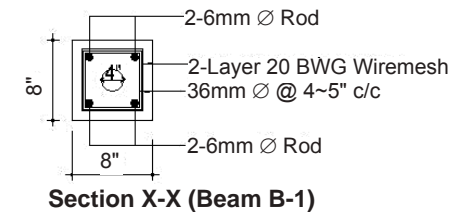
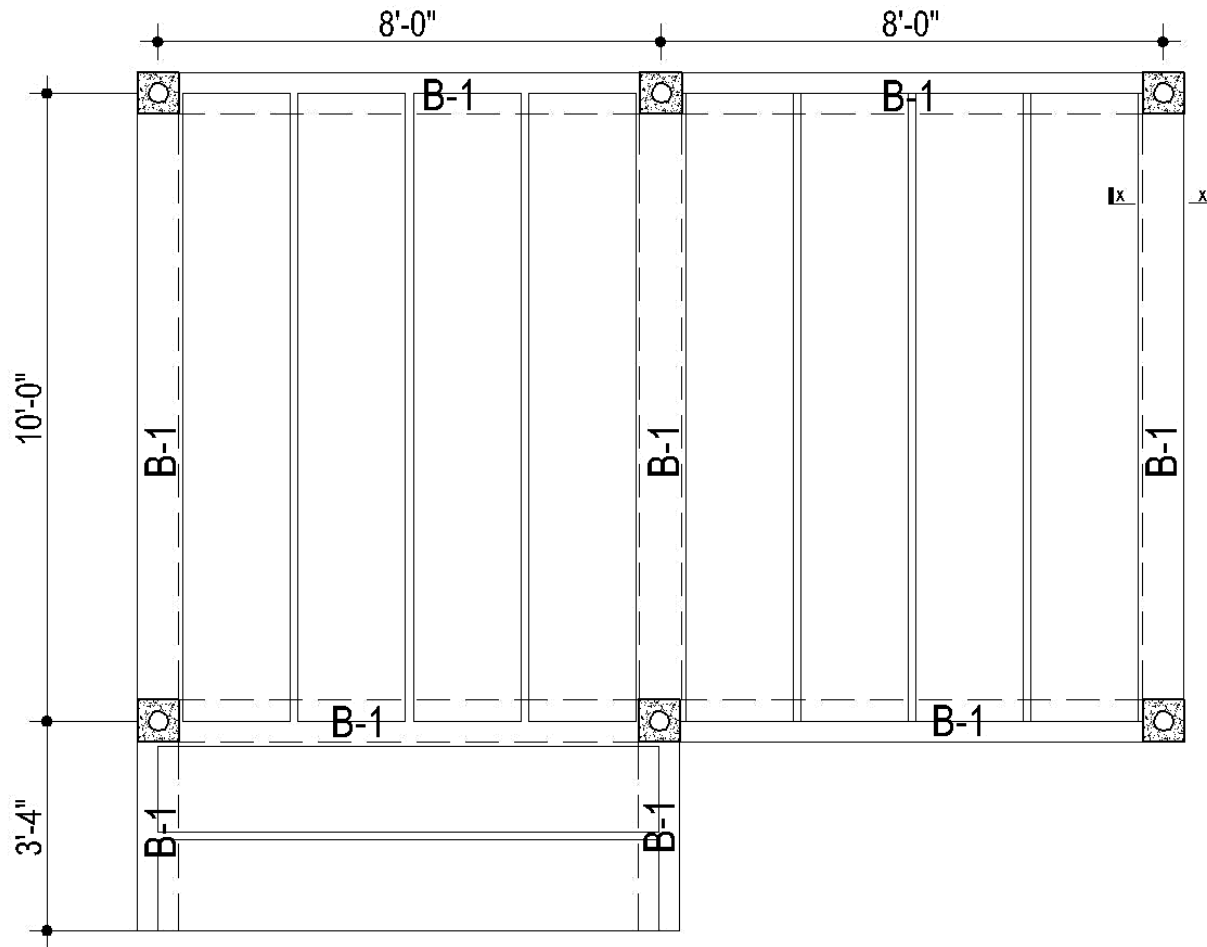

Floor Beam and Channel Arrangement

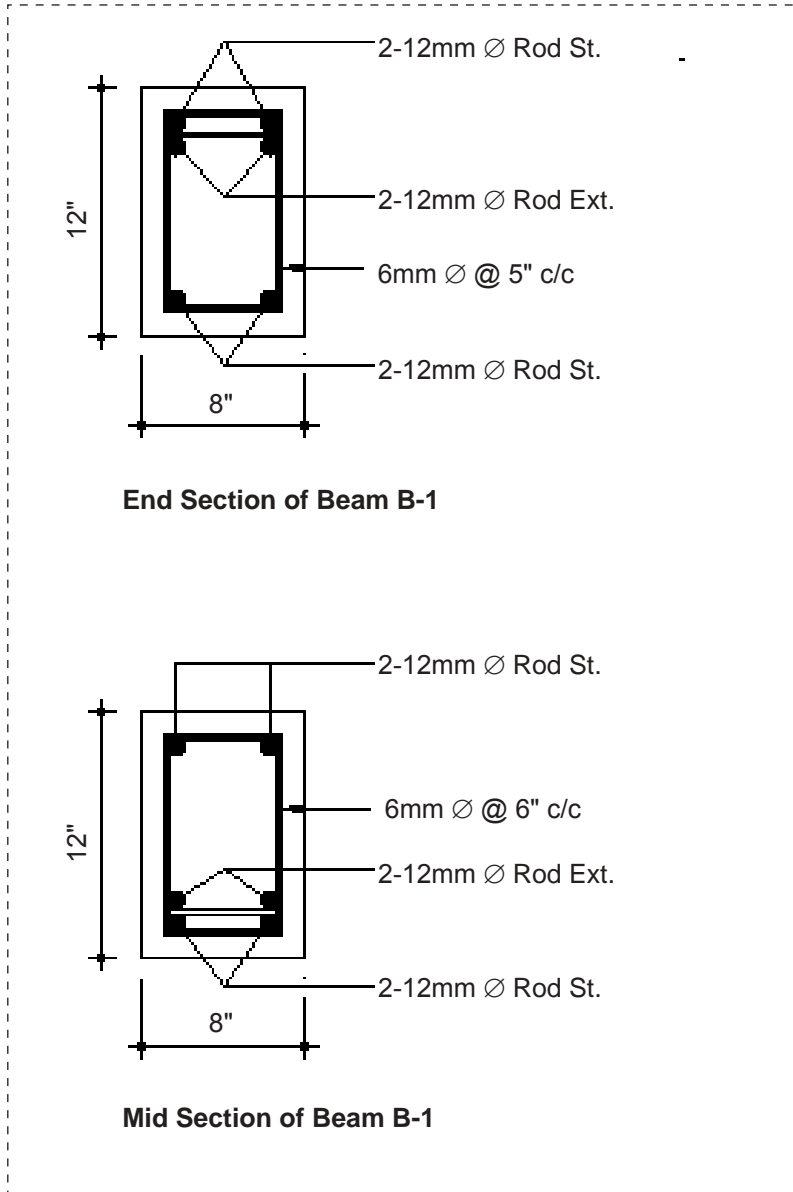

End and Mid sections

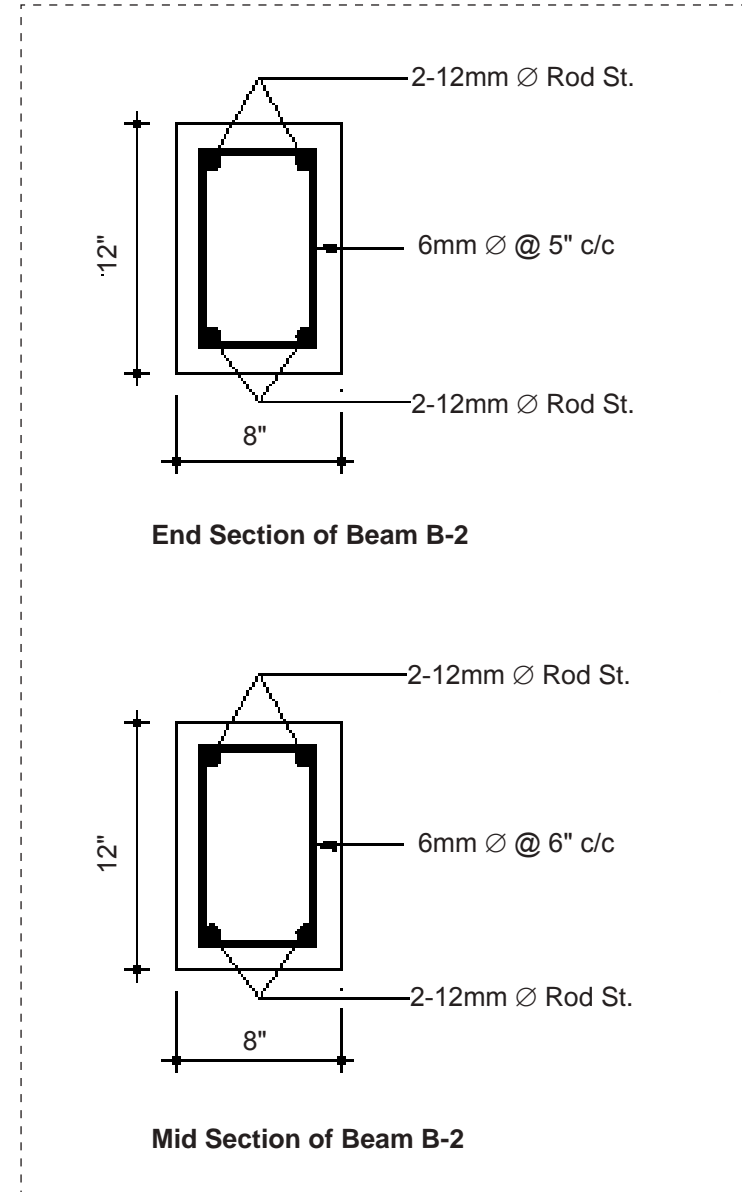

## COLUMN JOINT DETAIL FOR STILT HOUSE

Detail of Vertical Joint of Middle PC Column

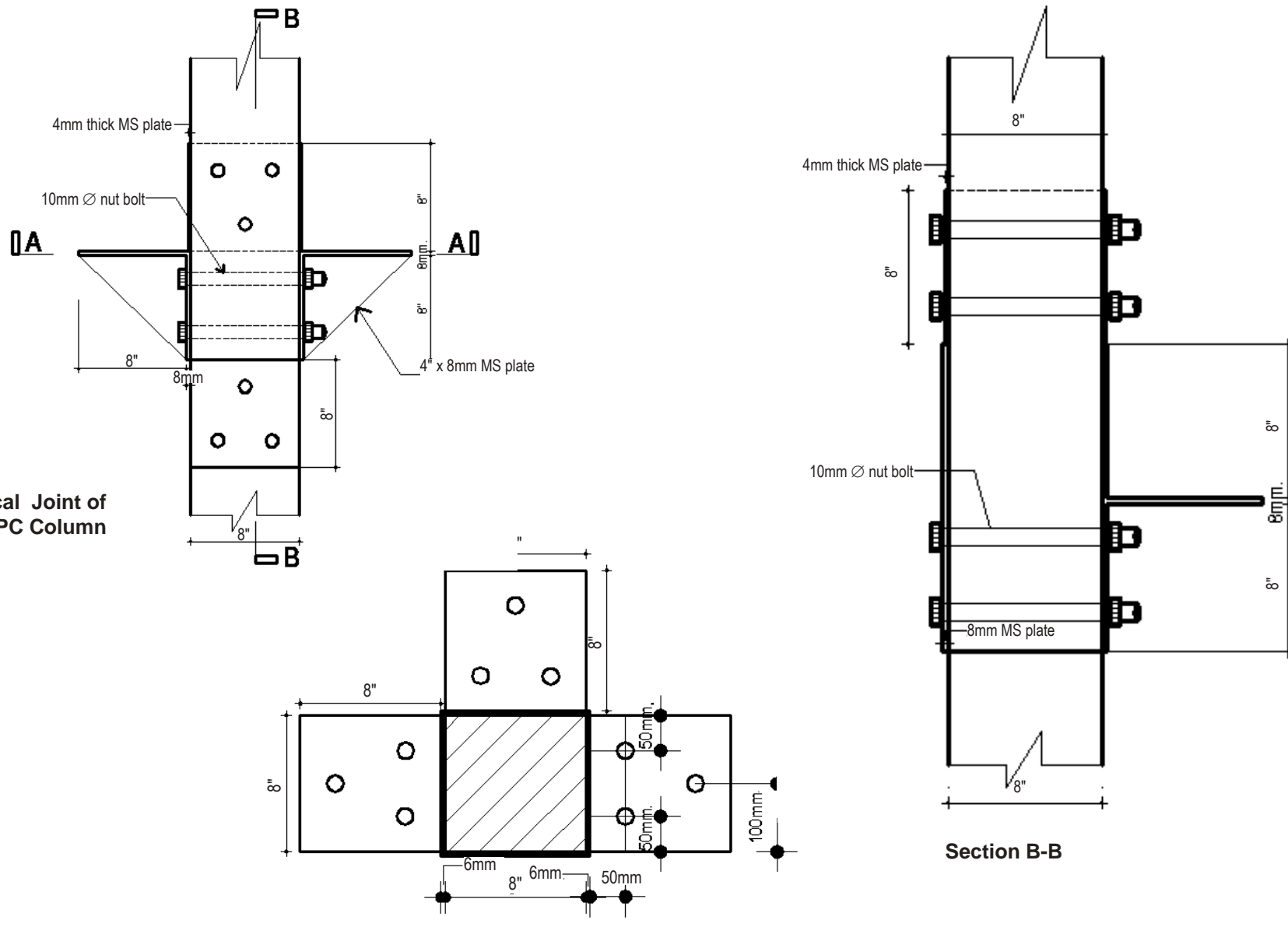

## FOOTING AND COLUMN LAYOUT PLAN

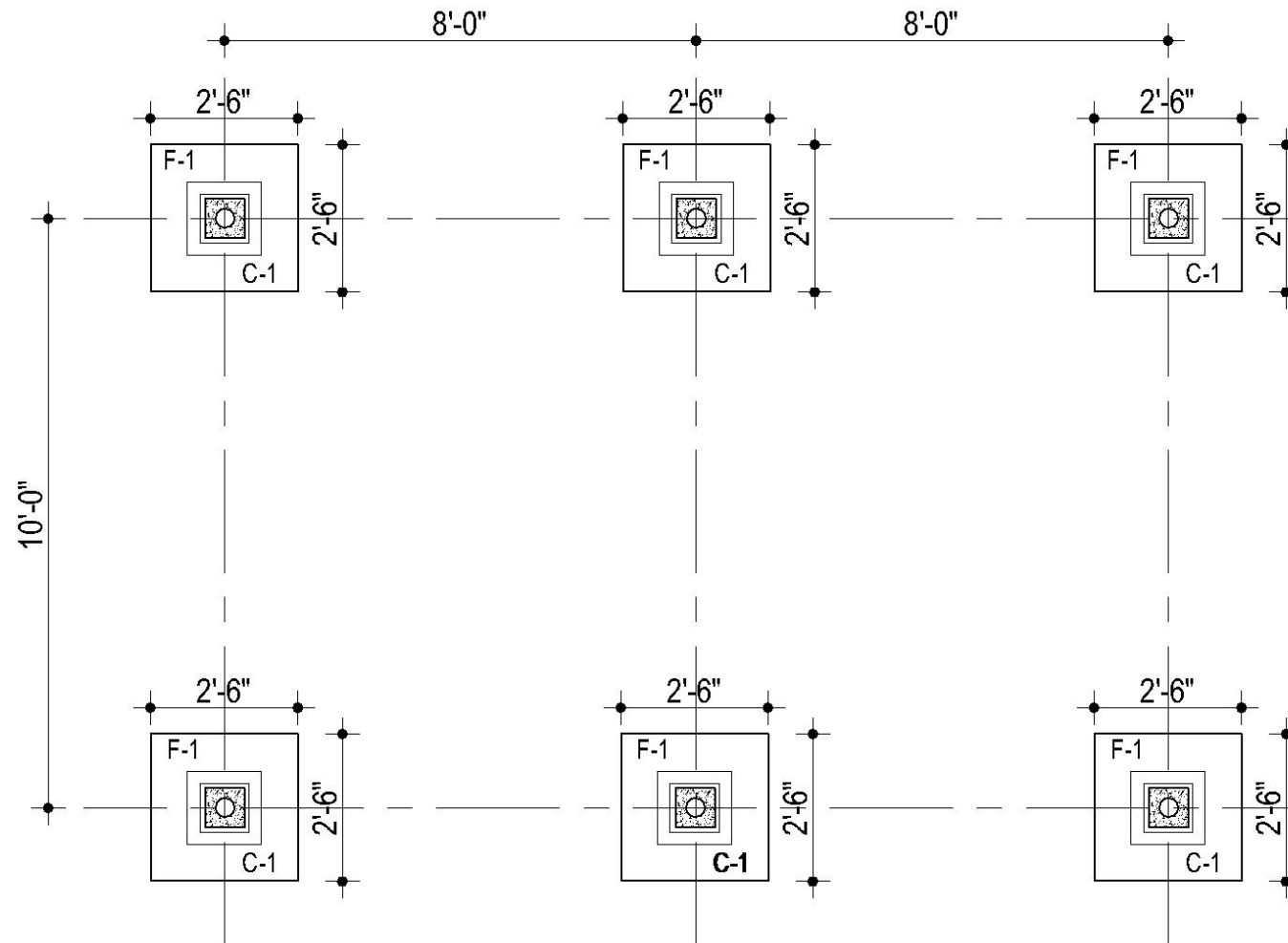

Footings and Column Layout Plan



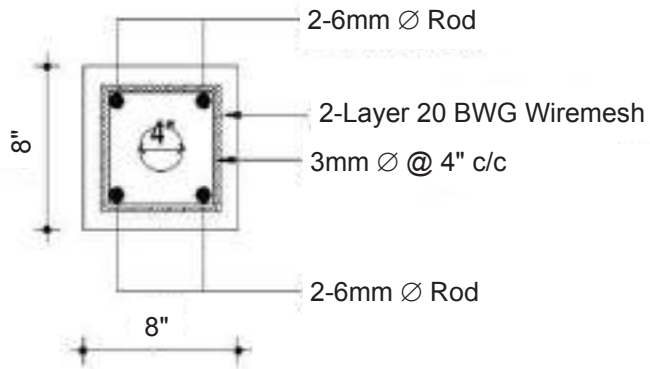

Section 1-1 (F.C. Hollow Column C-1)

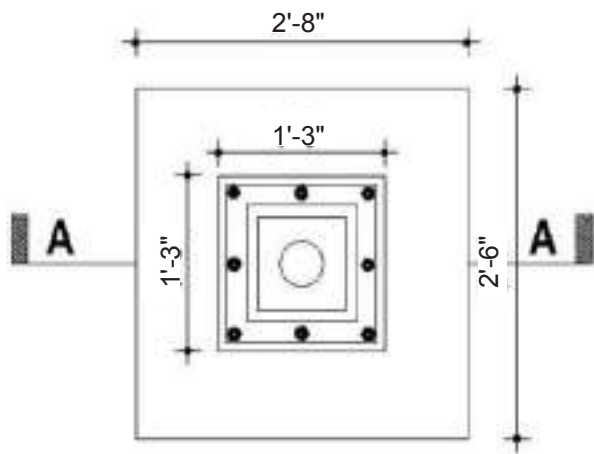

Plan of Precast (F.C.) Pocket Footing F-1

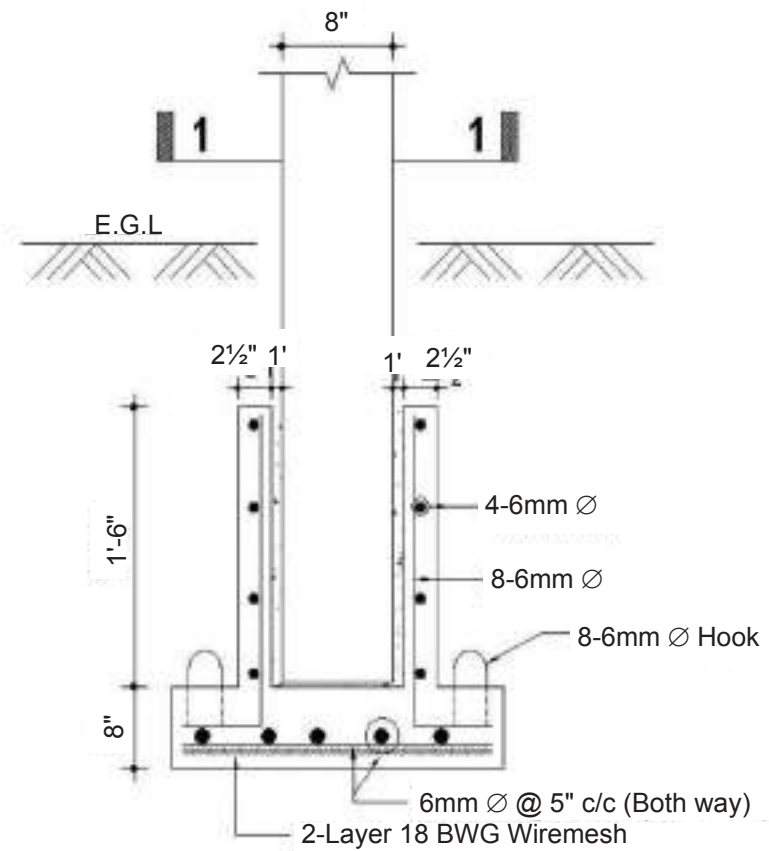

Section A-A

## BEAM-COLUMN LAYOUT

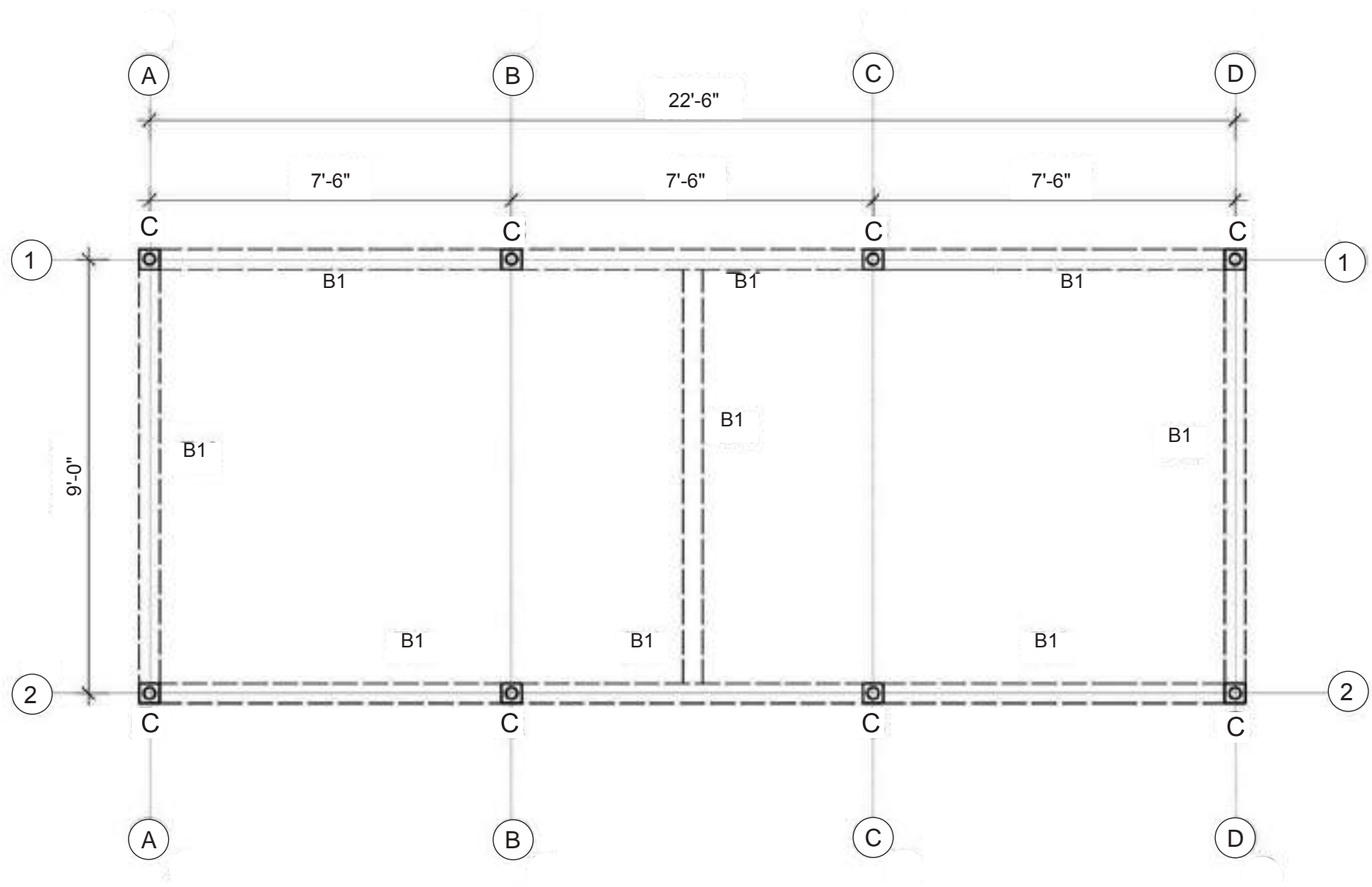

Beam-Column layout

## 6.3 FLOATING HOUSE

### 6.3.1 Plan

This whole cluster house module has been designed to help in rehabilitating the unsettled populace at various inundated/water logged/wetland areas of varying water depths. The total cluster comprises of six rooms in three detached pairs along with a service block all arranged in a pinwheel formation. This planar formation helps in achieving due climatic comfort parameters along with providing extra outdoor spaces to accommodate extra additional service requirements in between every pairing blocks. The resulting central space acts as a hub for daily life activities.

The whole structure has been designed to get built upon harnessing the technologies of ferrocement construction. The ferrocement technology helps in reducing for the unnecessary weights while also maintaining the economy of construction for a formidable yet floating house cluster unit. The pontoon like base, apart from enabling the structure to float, can also be utilized for other forms of services namely extra storage space, water reservoir etc.

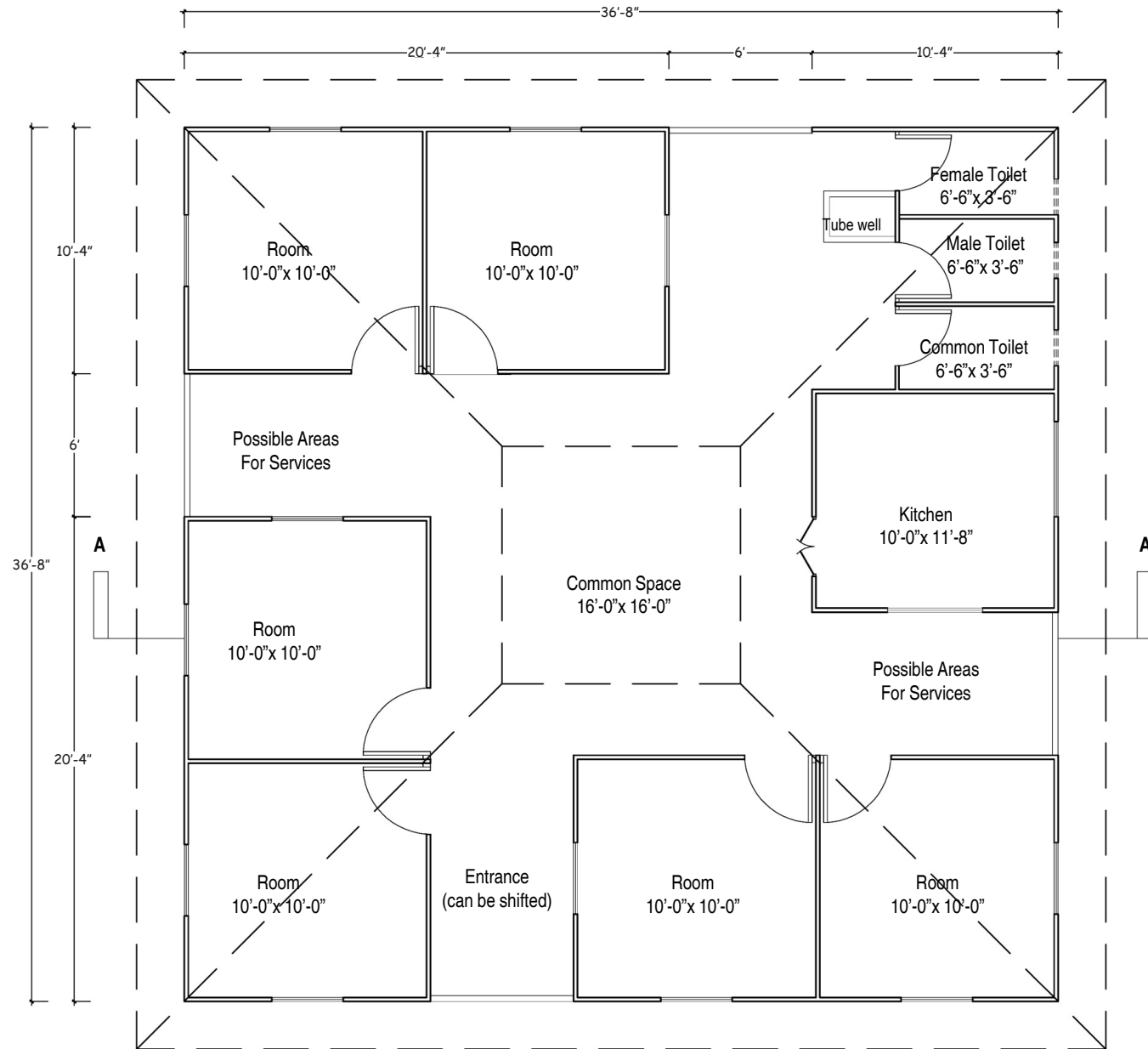

Floor plan

### 6.3.2 Section and Elevation

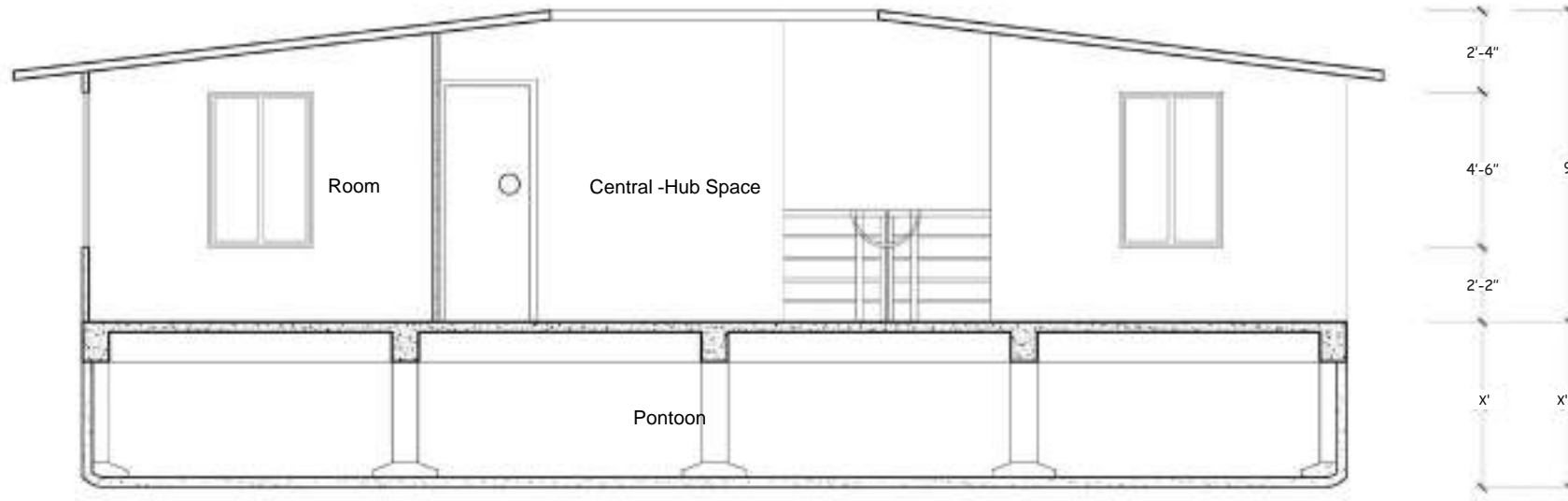

**Section AA**  
(see plan for the section line)

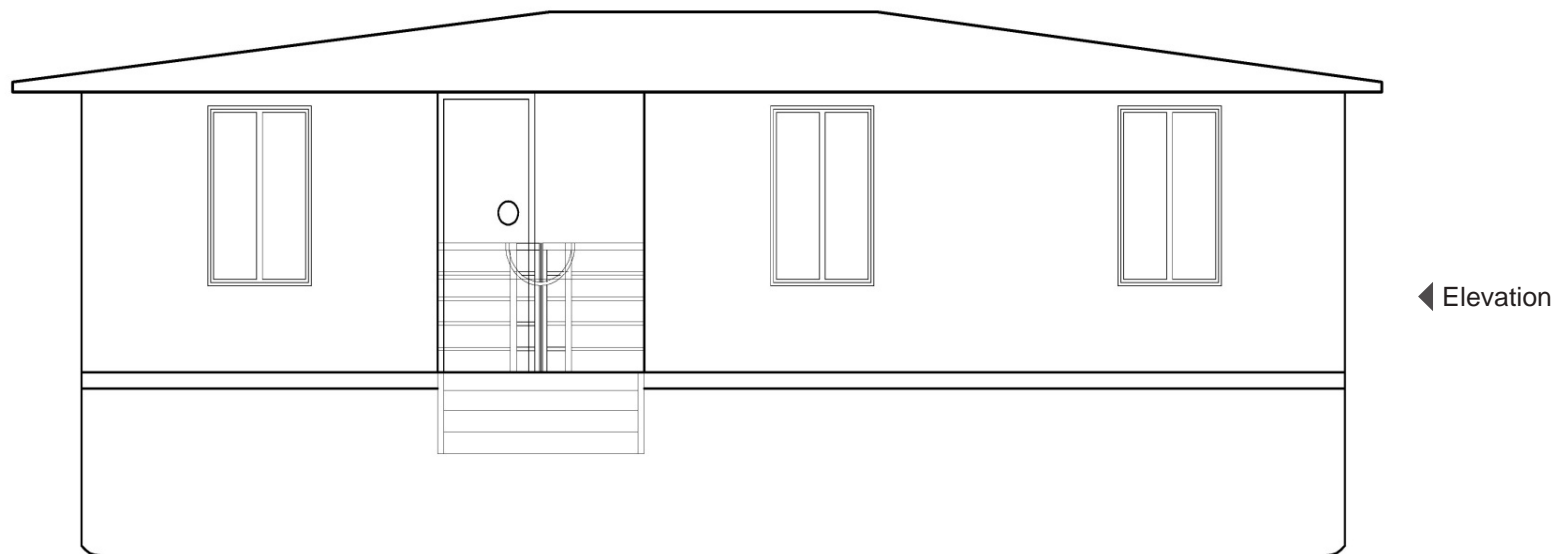

### 6.3.3 Complete Built Form

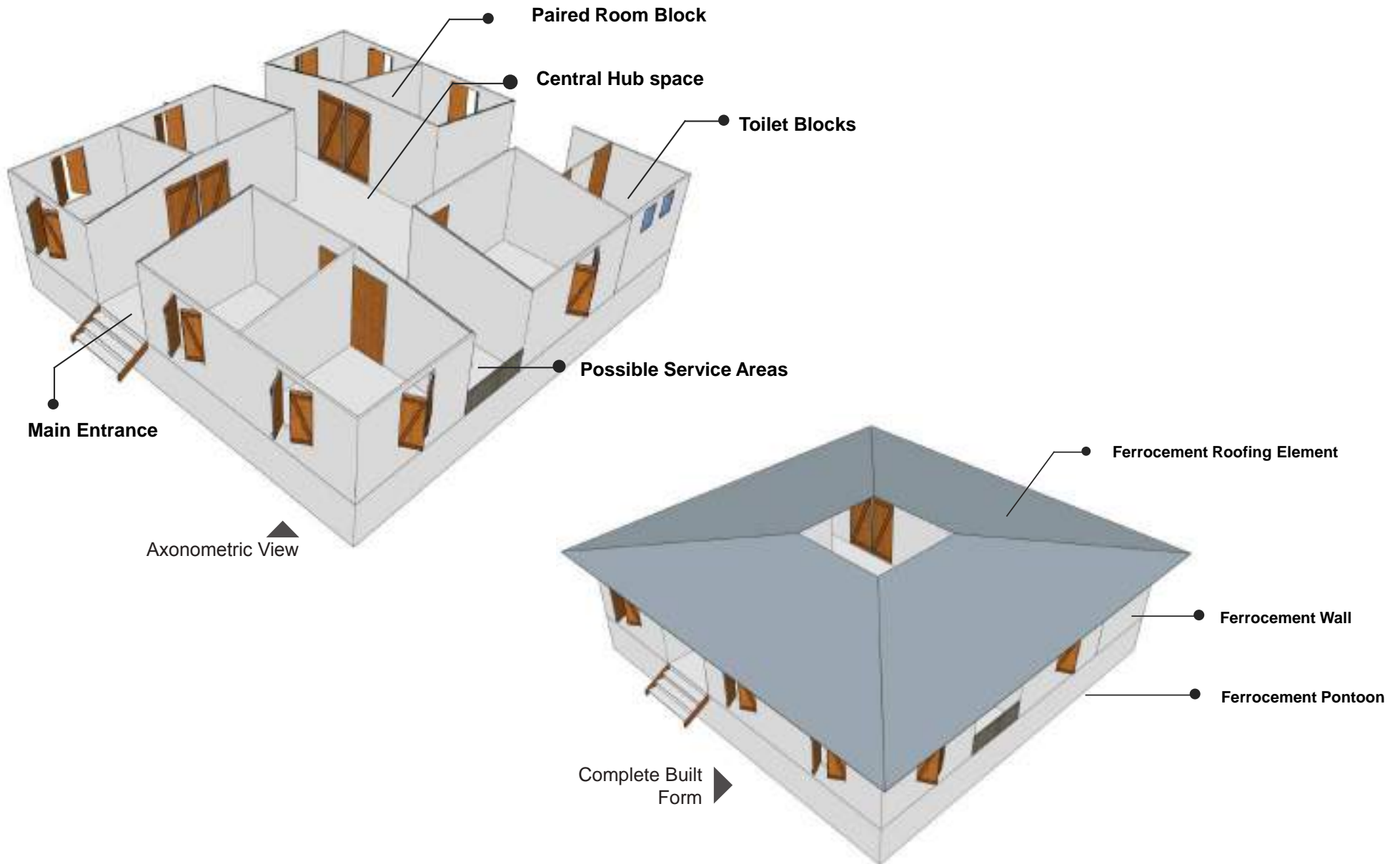



## 6.4 LOAD BEARING EARTH BAG HOUSE

### 6.4.1 Plan

This house type proves its worth against the conventional load bearing mud wall (approx. 12" thick) structures that often fails to endure the impacts of various lateral forces including seismic occurrences. The whole structure is crafted out of

continuous linear earth bag courses tightly filled with compressed earth and structurally reinforced with accompanying barbed wire elements. To further reinforce the structure against the occurring impacts a FC/RCC top plate is provided all over the final course of earth bag modules. Additional buttresses are projected out of corners and at other strategic

wall points to assure heavy durability. Finally plastered, this particular load bearing form of house can turn into a true alternative for practicing mud wall structure.

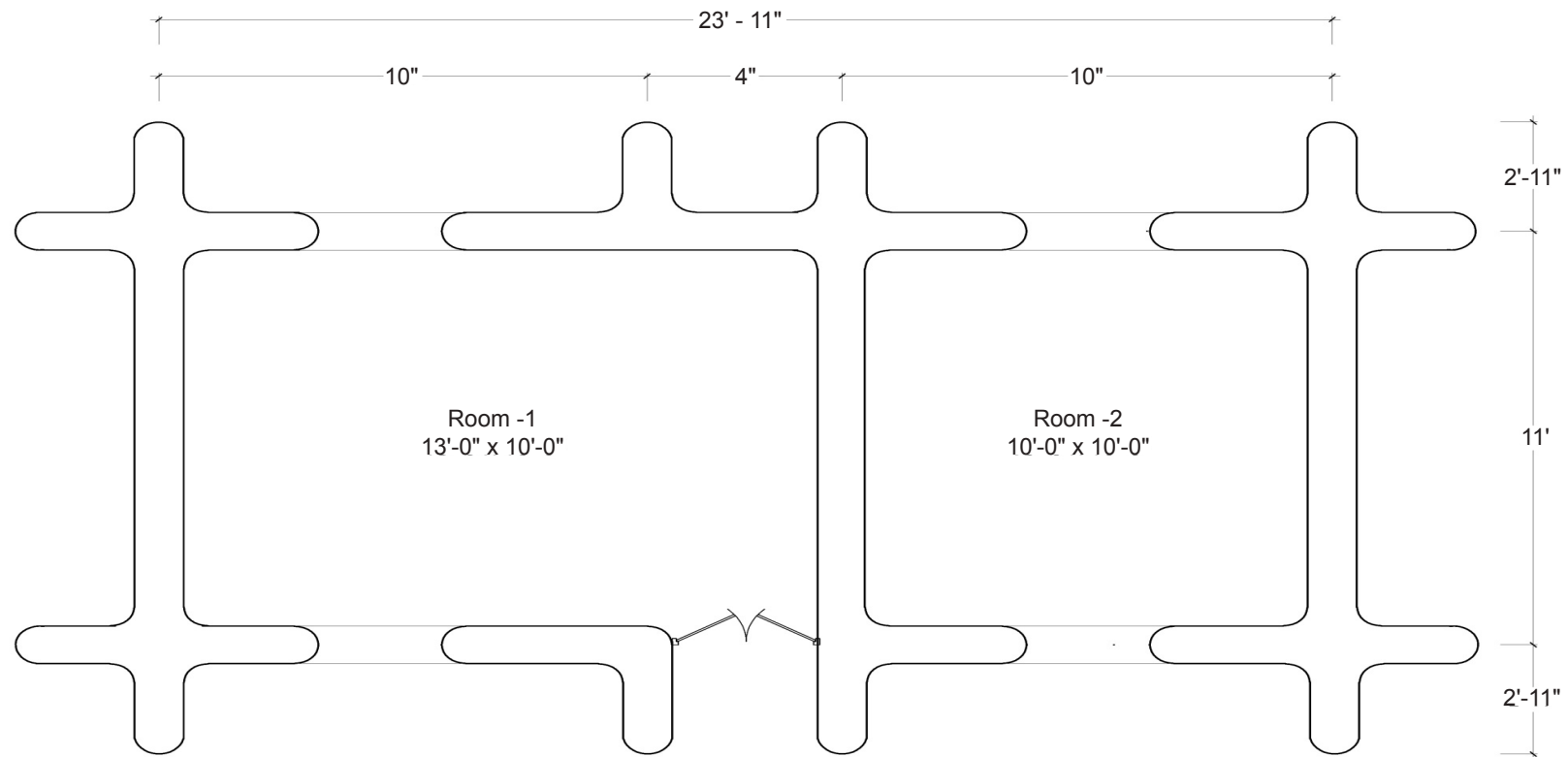

Floor plan

## FORMATION OF HOUSE MODULE

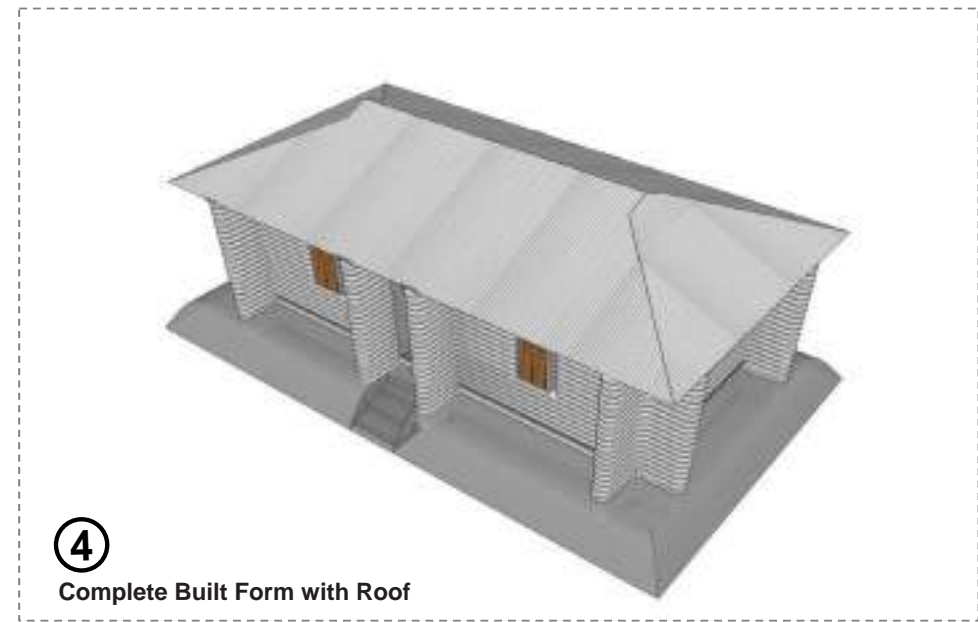
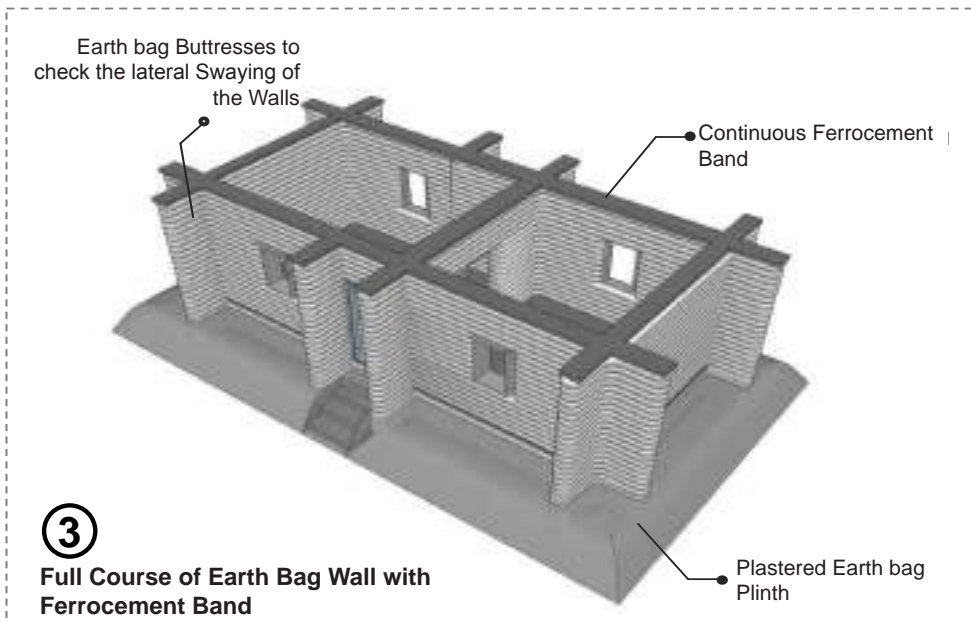
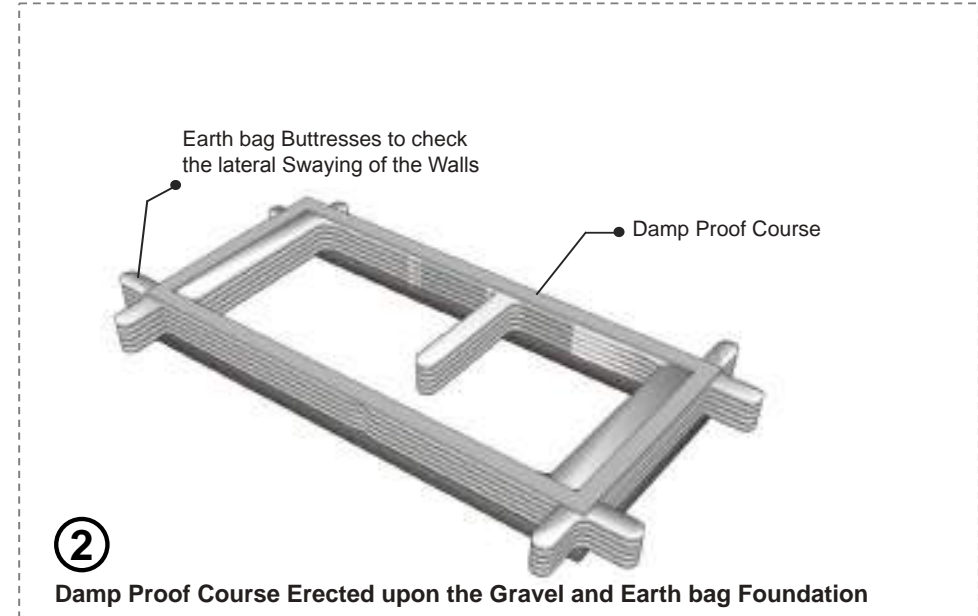
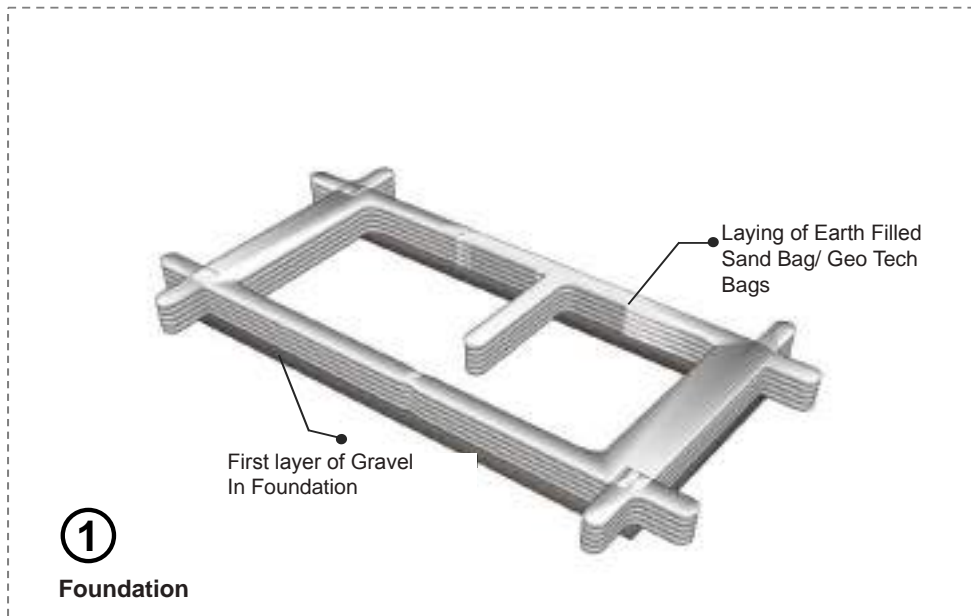

## COMPLETE BUILT FORM DETAILING

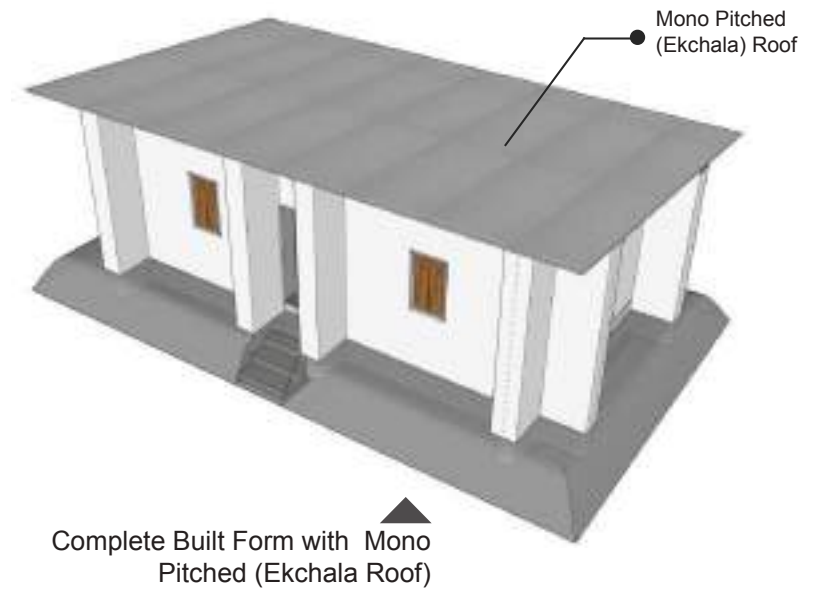
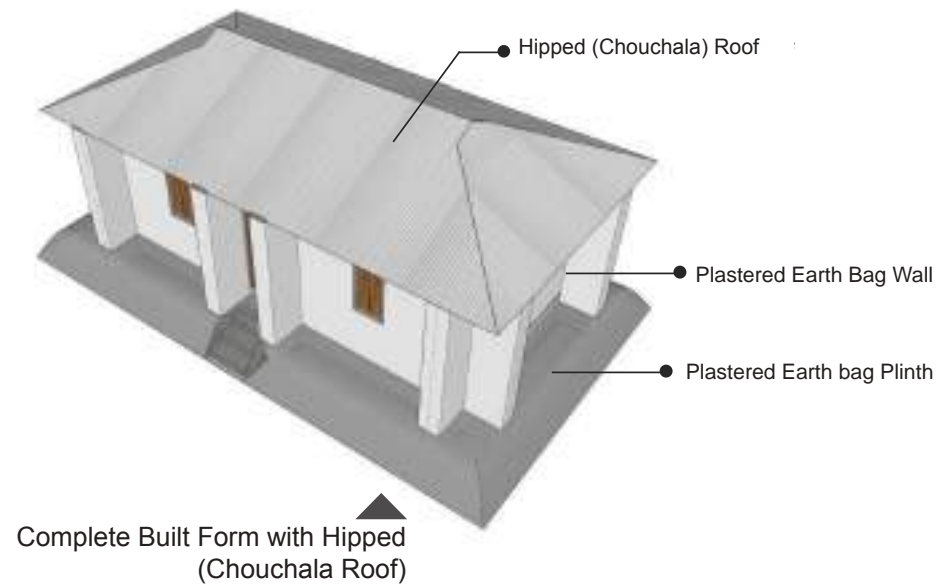

## ROOFING ELEMENTS



Ferrocement L-Panel



Ferrocement Folded Plate



CGI Sheet



Ferrocement Corrugated Sheet



## CHAPTER SEVEN

# DESIGN MEASURES FOR SERVICES

### 7.1 FLEXIBILITY IN ACCOMMODATING ACCESS AT MULTIPLE POINTS

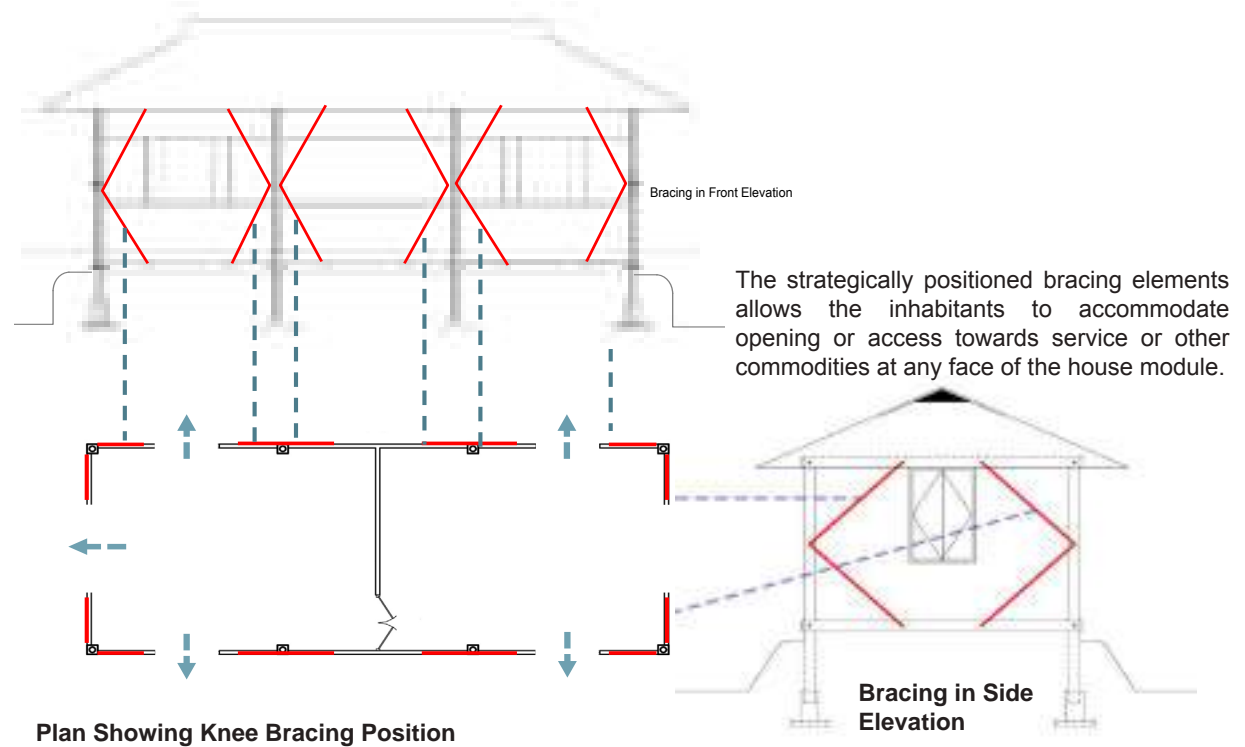

## 7.2 SERVICE ACCOMMODATION AND FUTURE EXPANSION

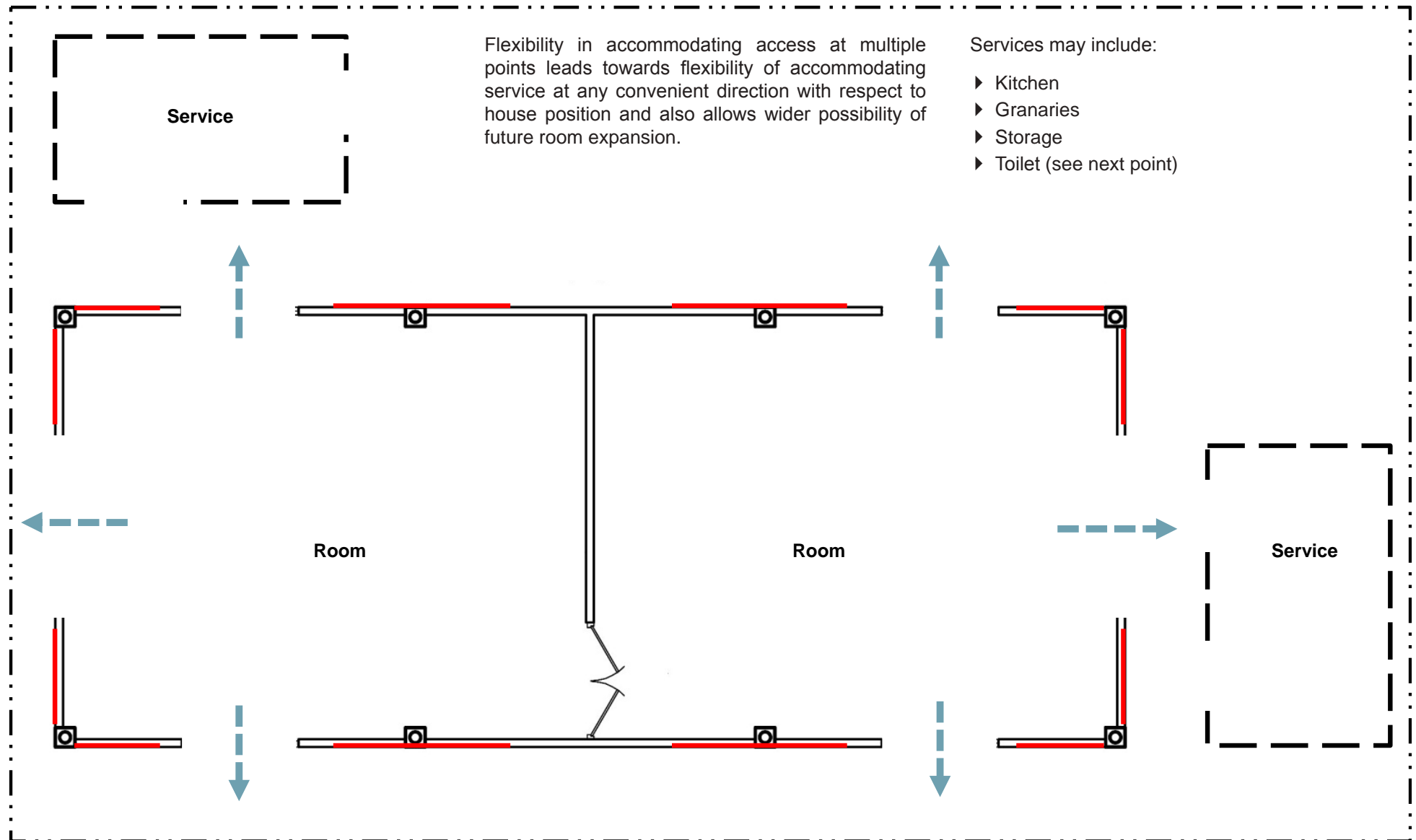

## 7.3 SANITATION MODELS

### Toilet Model-1: Simple Pit Latrine

- ▶ Toilet unit at higher grounds free of flooding.
- ▶ Stabilized plinth
- ▶ Pit is constructed of stacked circular RCC/ FC pit ring
- ▶ Occasional lid upon the pit opening.

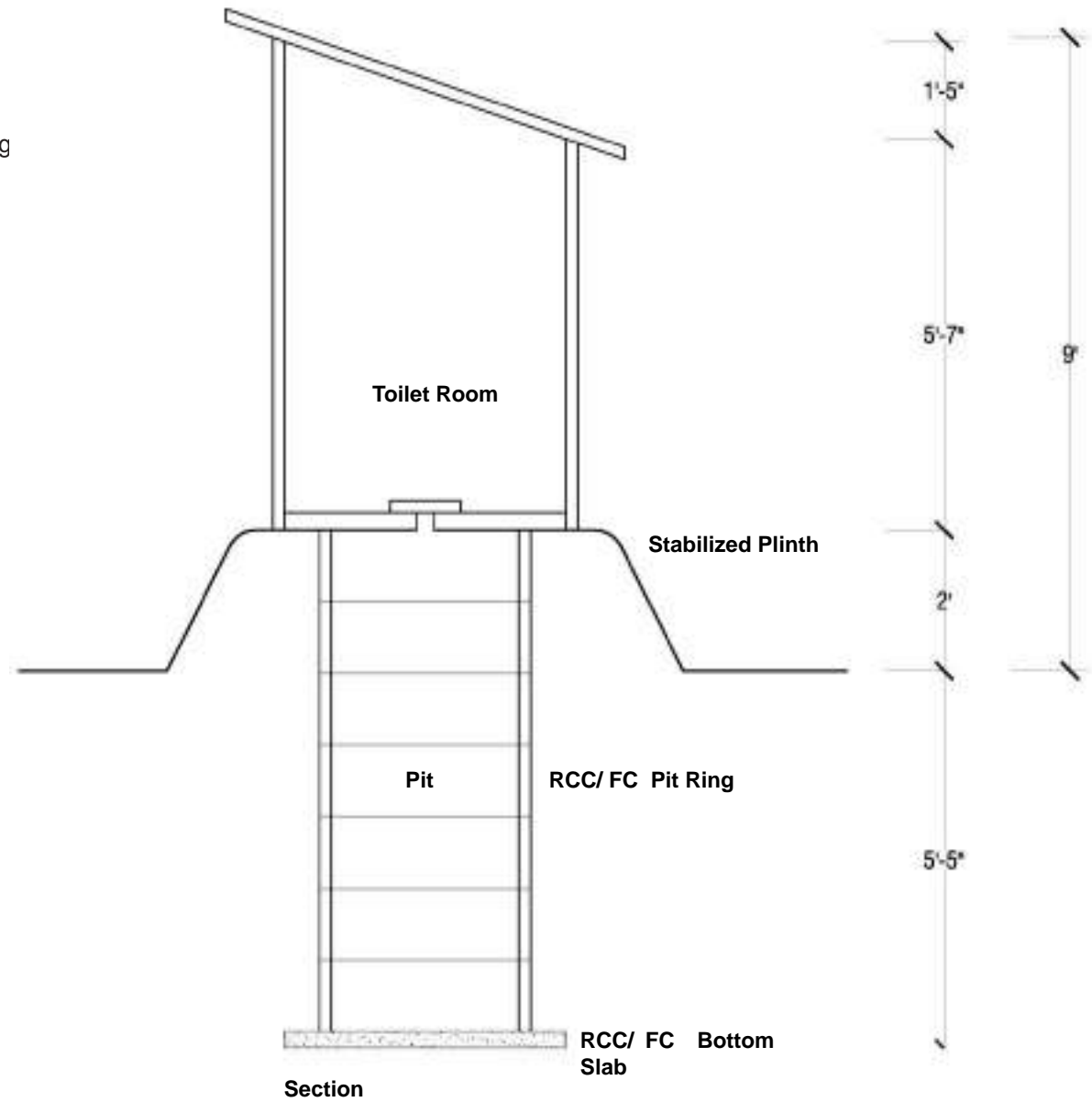
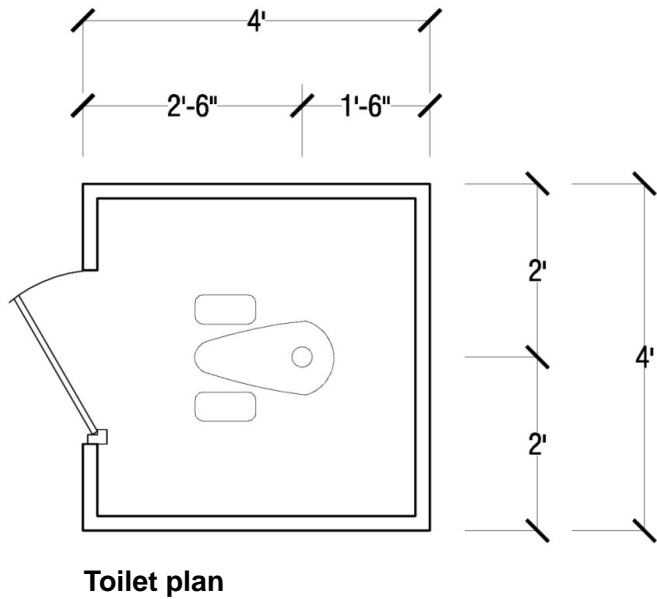



## Toilet Model-2: Dual Pit Latrine

- ▶ Toilet unit at higher grounds free of flooding.
- ▶ Stabilized plinth
- ▶ Two dry pits are employed; effluent runs off to another when one is filled
- ▶ Pit is constructed of circular and perforated masonry wall wrapped with external mesh.
- ▶ Pits are covered with RCC/F.C lids

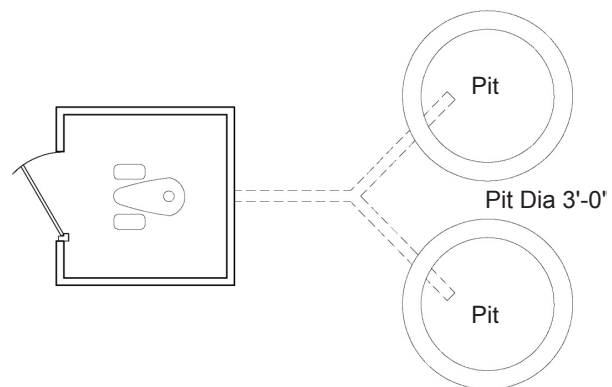

Toilet plan (4'-0"X4'-0")

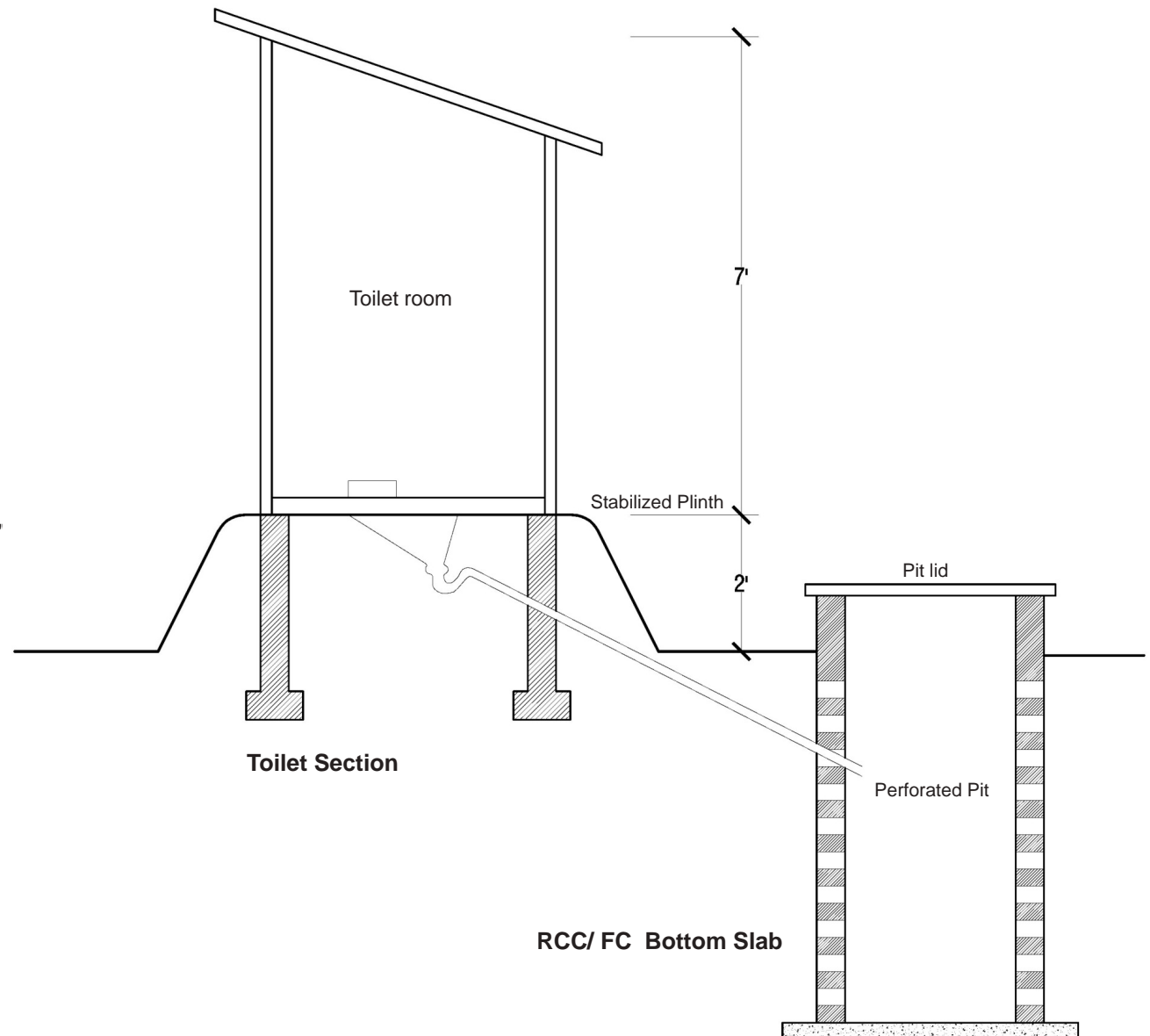

### Toilet Model-3

- ▶ Toilet unit at areas facing risk of flooding  
Stabilized plinth
- ▶ Pit is constructed of either RCC/FC
- ▶ Pits are covered with RCC/F.C lids
- ▶ The whole toilet room module floats with fluctuating water level.
- ▶ Innovative features like hollow drums, flexible pipes are installed to help in floating mechanisms as well as to support due functionality while at transient state.
- ▶ Keeps the options open for further innovation and development
- ▶ 4'-0"X4'-0" Toilet module

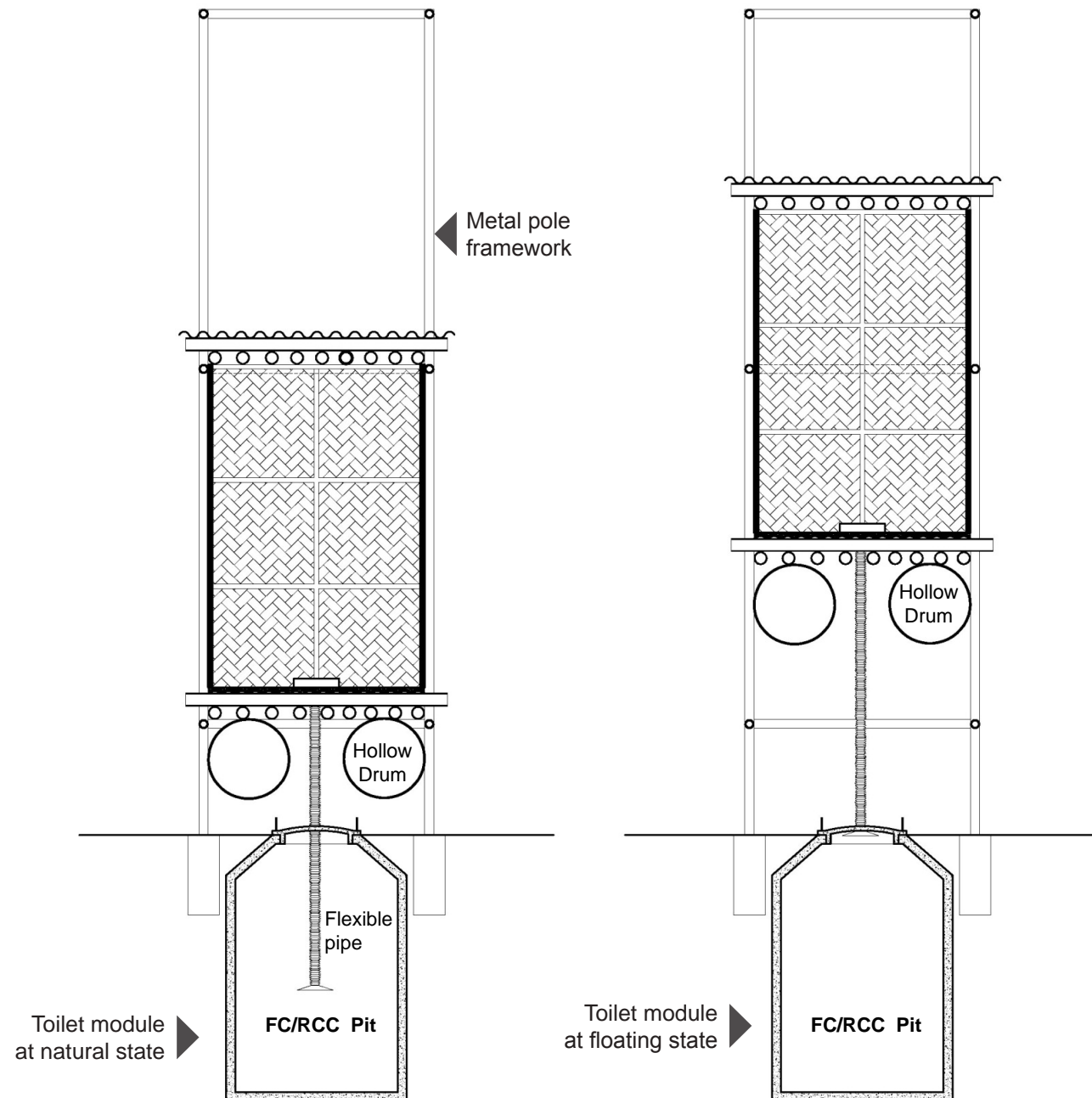

## 7.4 UNIVERSAL ACCESSIBILITY

Considering the issues of universal accessibility, several options have been reformed. The following plans show different options for universal accessibility.

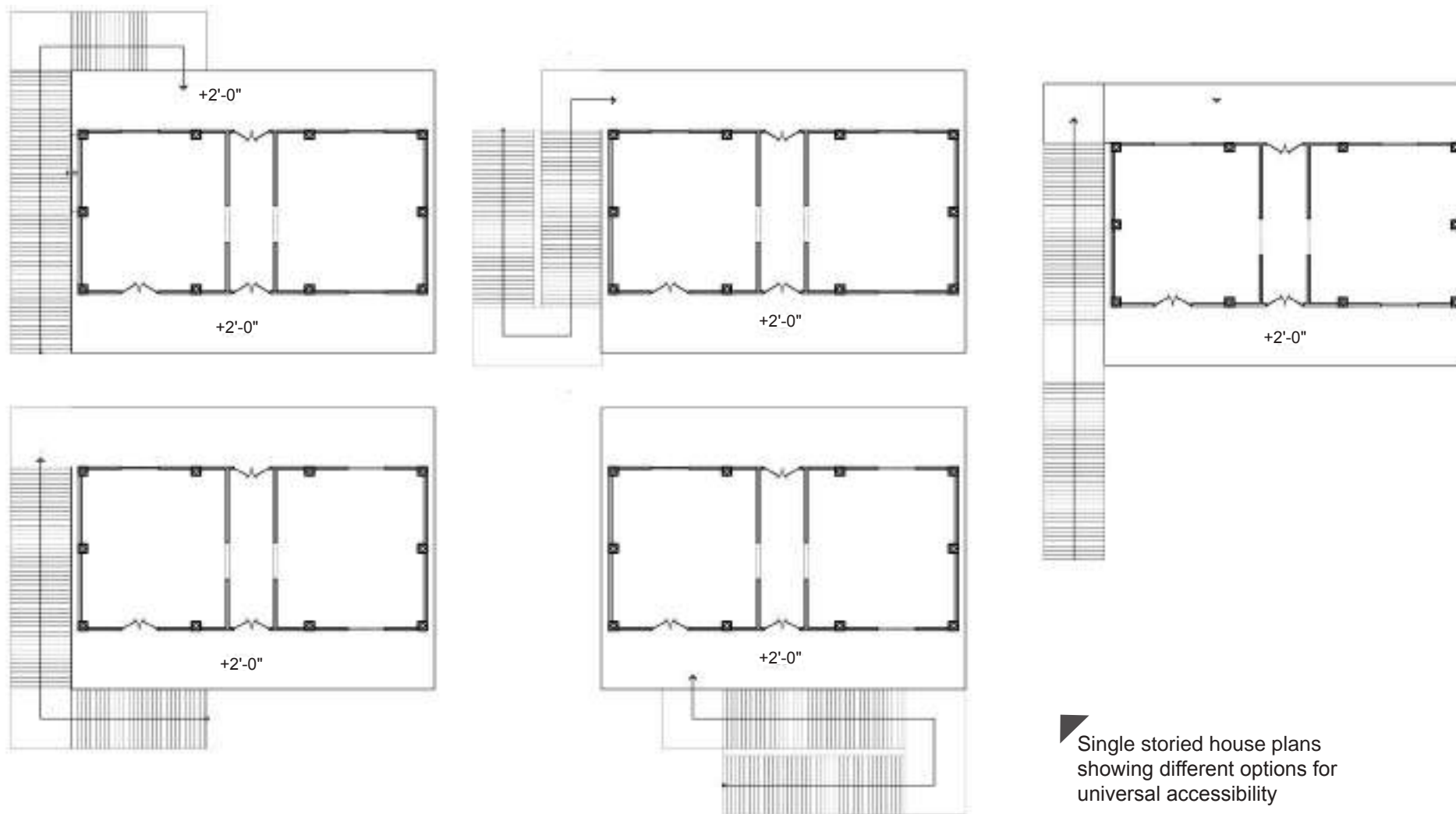

Single storied house plans showing different options for universal accessibility

## UNIVERSALLY ACCESSIBLE STILT HOUSE WITH MULTIPLE UNIT OPTIONS

Considering the Inhabitant's requirement the house module can be multiplied around the given position of the staircase and formed into a cluster of multiple units. Accordingly the ramp can be placed ensuring universal accessibility.

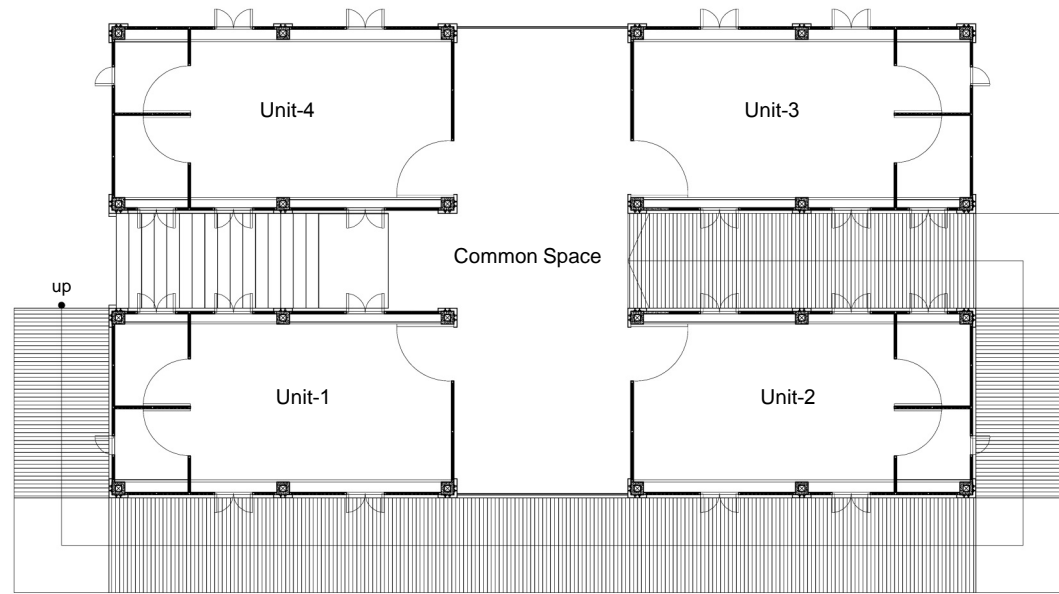

Stilt house plan with four units for universal accessibility



House plans showing different options for universal accessibility



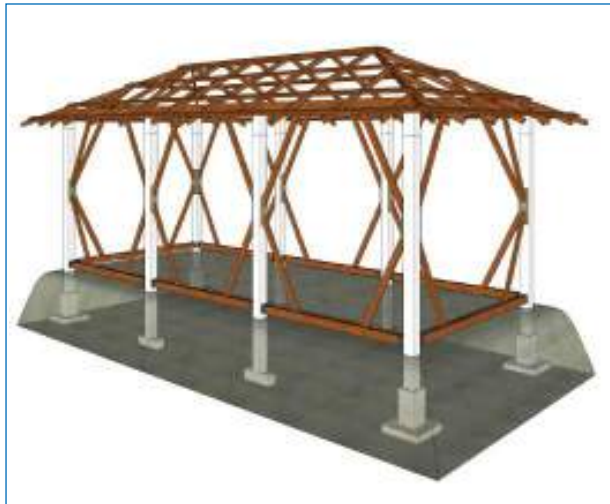

## CHAPTER EIGHT

# END USER IMPROVISATIONS AND NON-ENGINEERED MEASURES

The community's/inhabitant's ability to comply with all the structural details depicted here, sometimes might come out to be limited, specially attributed to ultra-poor. In such cases, a few adaptations and improvisations may occur as per their ability yet addressing safety factors. As for example, few of such interventions out of many might take place in several aspects such as:

- Bracing
  - ▶ At Vertical Plane
  - ▶ At Roof Plane
- Roof – Ground Connection
- Replacing Structural Components of Roof Frame and Bracing Elements With Locally Available Materials

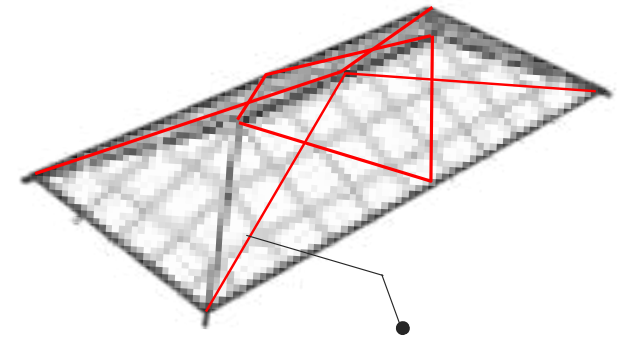

### **BRACING**

#### ***Bracing at Vertical and Roof Plane***

To make the structure more resistant against wind pressure, inhabitants may include bracing at roof plane. FC bar, wood, tensile elements e.g. stretched rubber from recycled tier, weather resistant thread/rope, GI wire etc. can be used as bracing elements

#### ***Bracing at Vertical Plane***

FC bar, wood, tensile elements e.g. stretched rubber from recycled tier, weather resistant thread/rope, GI wire etc. can be used as per inhabitant's choice/ability

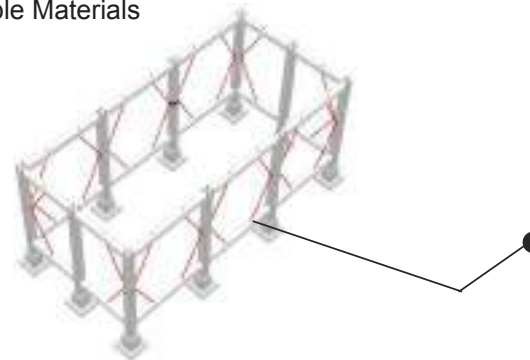

## ROOF - GROUND CONNECTION

Roof securing can be ensured by connecting the rafter with ground through tensile elements e.g. stretched rubber from recycled tier, weather resistant thread/rope, GI wire etc.

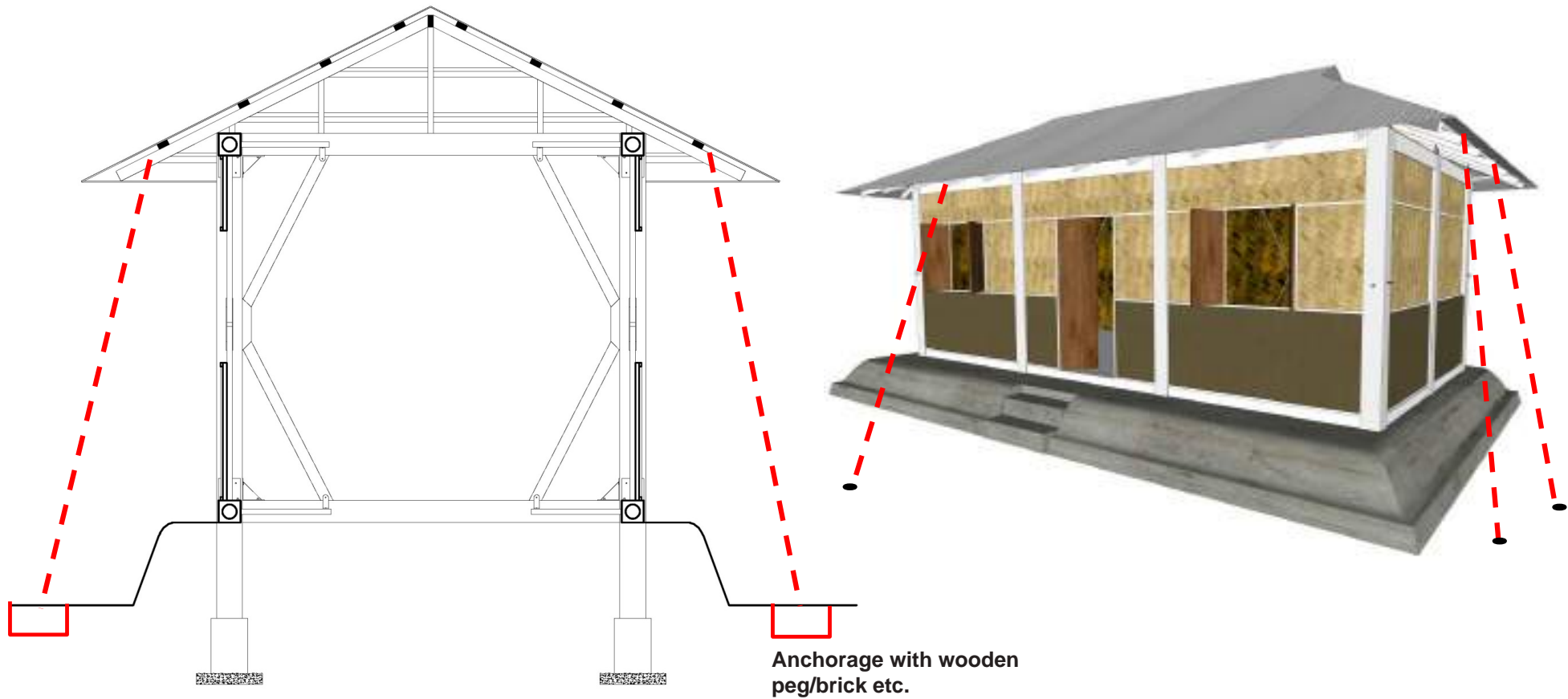



## REPLACING STRUCTURAL COMPONENTS OF ROOF FRAME AND BRACING ELEMENTS WITH LOCALLY AVAILABLE MATERIALS

In addition to the durable core structural framework of RCC and Ferrocement elements, locally available timber and bamboo can also be used as the bracing,

roofing and other joinery elements. In that case the roofing skin can be of any lightweight organic materials like thatch, available dry leaves etc.

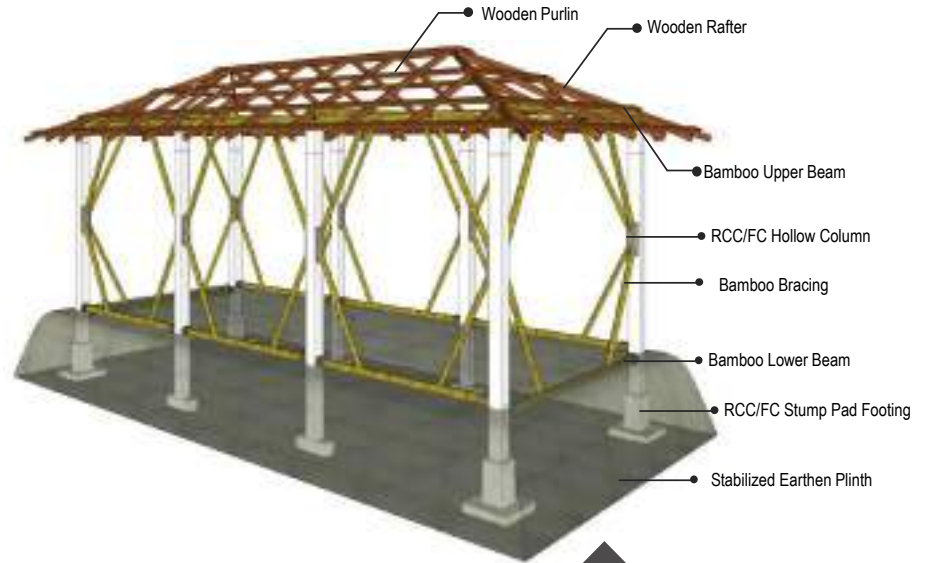
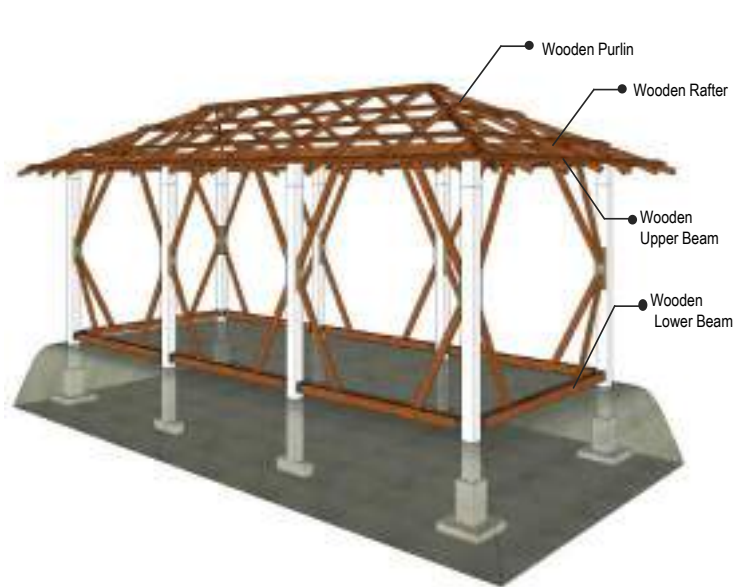

▲ Hipped (Chouchala) Roof Structural Frame with Timber

Timber and Bamboo as Bracing and Beam Elements

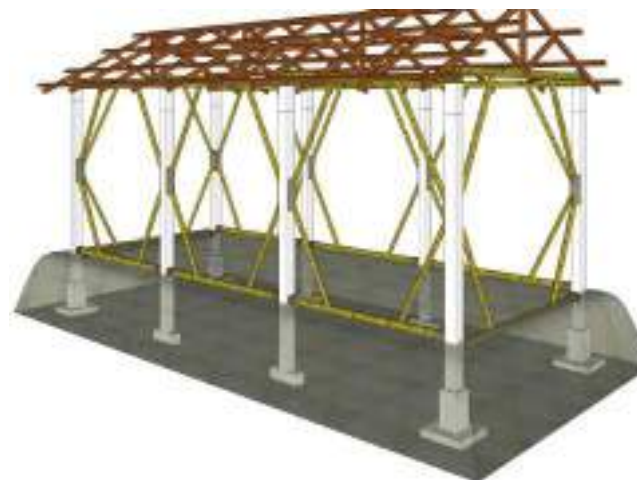
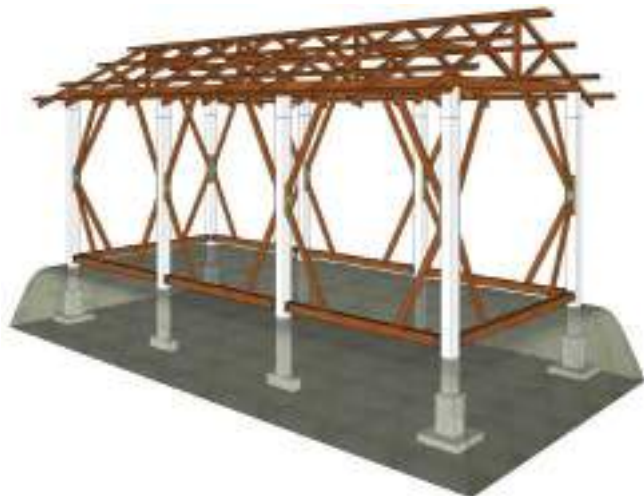

◀ Gable (Dochala) Roof Structural Frame with Timber

Timber and Bamboo as Bracing and Beam Elements

## NOTE

The Design guideline and Catalogue can help to ensure an adequate, safe and affordable housing for all, specially living in the extreme climatic zones of Bangladesh. However the design catalogue does not cover some issues like water supply, rain water

harvesting, renewable energy management etc. In the long run the guideline can help to facilitate an improved living condition for the inhabitants living in extreme natural conditions.

# REFERENCES

1. Ahmed, KI, 2005, Handbook on Design and Construction of Housing for Flood-Prone Rural Areas of Bangladesh, ADPC, Dhaka
2. Haq, B, 1999, Battling The Storm: Study on Cyclone Resistant Housing, German Red Cross, Dhaka
3. Shaw, Mallick, Islam, 2013, Disaster Risk Reduction Approaches in Bangladesh, Springer, Japan
4. Islam, Siddiqua, 2014, "Using Indigenous Building Patterns to Cope with Natural Disasters: The Case of Cyclones in Bangladesh",
5. International Journal of Architecture, Engineering and Construction Vol 3, No 1, pp. 27-43
6. Caimi, A, 2012, Report on field visit, construction of pilot Low Cost House project for the Disaster affected families in Bangladesh, CRATERre, Bangladesh
7. 2014, Disaster Report 2013, Department of Disaster Management, Ministry of Disaster Management and Relief, Government of the People's Republic of Bangladesh
8. <http://www.adrc.asia/countryreport/BGD/BGDeng98/>
9. [http://www.saarc-sadkn.org/countries/bangladesh/disaster\\_mgt.aspx](http://www.saarc-sadkn.org/countries/bangladesh/disaster_mgt.aspx)
10. Desai, Desai, 2008, Manual on Hazard Resistant Construction in India For reducing vulnerability in buildings built without engineers, NCPDP, India
11. Desai, Desai, 2008, The Trainer's Guide for Training in Hazard - Resistant Construction to ensure effective training of artisans for vulnerability reduction, UNDP, India
12. 2015, DESIGN CATALOGUE FOR RECONSTRUCTION OF EARTHQUAKE RESISTANT HOUSES, Vol 1, Government of Nepal , Ministry of Urban Development ,Department of Urban Development and Building Construction

## BIBLIOGRAPHY

- Delegation of the European Union to Bangladesh. (2015). EU - Bangladesh Climate Diplomacy Day, 2015. *Together Building Resilience*.
- Disaster Management and Relief Division . (April 2010). Bangladesh Climate Change Strategy and Action Plan, 2009. *National Plan for Disaster Management*.
- Disaster Management Bureau: Disaster Management and Relief Division. (April 2010). *National Plan for Disaster Management*.
- Ministry of Disaster Management and Relief. (n.d.). Comprehensive Disaster Management Programme. *Disaster Risk Reduction and Climate Change Adaptation*.
- Ministry of Disaster Management and Relief. (n.d.). Coordination in Shelter and Housing. *Early Recovery Guiding Principles*.
- Ministry of Disaster Management and Relief. (June 2014). Hazard Maps. Local Level Hazard Maps for Flood, *Storm Surge and Salinity*.
- Ministry of Food and Disaster Management . (January 2010). *Standing Orders on Disaster*.

## HOUSING ACTORS FROM DIFFERENT ORGANIZATIONS PARTICIPATED IN THE PROCESS OF DEVELOPMENT OF THE GUIDELINE (The name of the organizations are placed according to alphabetic order)

### GOVERNMENT

1. Agriculture Extension Office-Kalapara
2. Cyclone Preparedness Program (CPP)
3. Department of Architecture
4. Department of Disaster Management (DDM)
5. Department of Public Health Engineering (DPHE)
6. Department of Livestock Services (DLS)
7. Housing and Building Research Institute (HBRI)
8. Ministry of Disaster Management and Relief
9. National Housing Authority
10. Public Works Department (PWD)
11. Rajdhani Unnayan Kartipakkha (RAJUK)
12. Upazila Parishad/administration -Gaibandha
13. Upazila Parishad/ administration-Kalapara
14. Upazila Education Office- Kalapara
15. Upazila Youth Development Office-Kalapara
16. Urban Development Directorate

### LOCAL GOVERNMENT

17. Dulara Union Parishad-Kalapara
18. Local Government Engineering Department-LGED
19. Sunamganj Upazila Parishad
20. Tiakhali Union Parishad-Kalapara

### UNIVERSITIES/INSTITUTIONS

21. Bangladesh University of Engineering and Technology-BUET
22. Institute of Architects Bangladesh-IAB

### PROJECT

23. Comprehensive Disaster Management Program-CDMP

### UN ORGANIZATION

24. UNDP Bangladesh
25. UN Habitat

### INTERNATIONAL NGOS

26. ActionAid
27. Bangladesh Red Crescent Societies
28. Care Bangladesh
29. Caritas Bangladesh
30. Concern Universal
31. Concern World wide
32. German Red Cross
33. Habitat for Humanity
34. International Federation of Red Cross and Red Crescent Societies (IFRC)
35. Islamic Relief Bangladesh
36. Muslim Aid
37. Oxfam
38. Practical Action Bangladesh
39. Save the Children
40. Swedish Red Cross
41. Tere des hommes
42. World Concern
43. World Vision

### NGO/CBA

44. Aesthetic & Sustaining D.
45. AVAS
46. CDD (Center for disability in Development)
47. Char Livelihoods Programme (CLP)
48. Efforts for Rural Advancement (ERA)
49. ESDO
50. FH Bangladesh
51. Friendship
52. Gono Unnaon Kendra-GUK
53. Gonoshasthaya Kendra
54. Jagorani Chakra Foundation
55. Jagroto Jubo shongho-JJS
56. Mukti Cox's Bazar
57. NSS

58. PGUK
59. PULSE- Bangladesh
60. RDWM
61. Rural AID
62. SDA
63. Shining Hill
64. SKS
65. Solidarity
66. Sunamganj Haor Unnoyon Parishd
67. SWF
68. Uddipan
69. UPAMA
70. Wave Foundation
71. YPSA-Young Power in Social Action

### PRIVATE ORGANIZATION

72. Bashirul Haq and Associates
73. GHORAMI.JON
74. URBANA

### MEDIA REPRESENTATIVE

75. Daily Amader Shomoy
76. Daily Sunamkonth
77. Daily Ittefaq
78. Daily Janakantho
79. Daily Sunamgonj Khabar
80. Daily Naya Diganta
81. NewAge
82. Prothom Alo
83. Bangladesh Sonbad Sonstha (BSS)
84. Channel 24
85. RTV
86. SATV
87. Somoy TV
88. bdnews24.com



হাউজিং এন্ড বিল্ডিং রিসার্চ ইনস্টিটিউট  
**Housing and Building Research Institute**  
 Ministry of Housing and Public Works

In collaboration with:



With technical assistance from:



International federation of Red Cross  
 and Red Crescent Societies  
**Shelter Research Unit**



**Shelter Cluster Bangladesh**  
 ShelterCluster.org  
 Coordinating Humanitarian Shelter

Sponsored by:



Development Cooperation  
 and Humanitarian Action  
 Grand Duchy of Luxembourg

**croix-rouge**  
 luxembourgeoise

